

# CONTENTS

Foreword	5
Society Council, 1976–79	6
Welcoming addresses	7
Participants	11
Section 1: Origin, dispersal, and evolution	19
Papers by: Léon 20; Plucknett 36; Sadik 40; Martin 44; Mendoza 50; Kobayashi and Miyazaki 53; Degras 58; and Warid et al. 62	
Summary of discussions	65
Section 2: Basic productivity	69
Papers by: Loomis and Rapoport 70; Holmes and Wilson 84; Ferguson and Gumbs 89; Dharmaputra and de Bruijn 94; Nitis and Suarna 98; Obigbesan et al. 104; Ngongi et al. 107; Howeler et al. 113; Rendle and Kang 117; Mohan Kumar et al. 122; Edwards et al. 124; Wahab 131; Umanah 137; Montaldo and Montilla 142; Montilla et al. 143; Wilson et al. 146; Tanaka and Sekioka 150; and Sykes 151	
Summary of discussions	152
Section 3: Preharvest and postharvest losses	155
Papers by: Lozano and Terry 156; Bock et al. 160; Mukiibi 163; Mukiibi 169; Terry 170; Ninan et al. 173; Leu 175; Terry 179; Obigbesan and Matuluko 185; Bellotti and van Schoonhoven 188; Nyiira 193; Yaseen and Bennett 197; Pillai 202; Thompson et al. 203; and Albuquerque 207	
Summary of discussions	208
Section 4: Utilization	211
Papers by: Christiansen and Thompson 212; McCann 215; Chandra and De Boer 221; Valdes Sanchez 226; Phillips 228; Oke 232; Delange et al. 237; Hew and Hutagalung 242; Khajarern and Khajarern 246; Varghese et al. 250; Hutagalung and Tan 255; Gomez et al. 262; Gregory et al. 267; Nartey 270; Nakayama et al. 274; and Jeffers 275	
Summary of discussions	277



## Foreword

The International Society for Tropical Root Crops held its Fourth International Symposium at the Centro Internacional de Agricultura Tropical (CIAT) in Cali, Colombia, from 1 to 7 August 1976. Over 170 scientists from 44 countries took part in the sessions.

The participants were welcomed to CIAT by its Director-General Dr John Nickel, who stressed the importance of tropical roots and tubers in the diet, especially of lower income groups in developing countries. Participants were then welcomed on behalf of the Government of Colombia by Dr J. Franco, the Director General of the Instituto Colombiano Agropecuario; by Dr H. A. Al-Jibouri speaking on behalf of the Director General of the Food and Agriculture Organization of the United Nations; and finally by Mr D. G. Coursey the Society's President.

The week-long symposium focused consecutively on four main themes: (1) Origin, dispersal, and evolution; (2) Basic productivity; (3) Preharvest and post-harvest losses; and (4) Utilization. Each theme commenced with a plenary paper — usually by a distinguished scientist from outside the tropical root crop field. Following the discussion on this paper in terms of its relevance to root crops, contributed papers on the theme topic were presented. Many of these dealt with the better-known root crops such as cassava, yams, potatoes, and sweet potatoes, although there were an encouraging number of contributions dealing with some of the lesser-known root crops, and as in previous symposia, an occasional paper discussing the potential of a virtually unknown species. Over 200 papers were submitted of which more than 60 were selected for presentation at the meeting. In addition to the paper presentations, participants took part in two field trips.

As mentioned in Mr Coursey's address, financial assistance to the Symposium was provided by CIAT, IDRC, and USAID. IDRC is pleased to be associated with CIAT, USAID, and the Society in jointly publishing these proceedings. The format of this publication follows that used for the proceedings of the cassava workshops sponsored by IDRC in that the discussion has been included in point form rather than in question and answer style. This has only been possible through the collaboration of a number of Society members who acted as discussion rapporteurs and summarized the main points of the discussion periods. Thanks are due to them and to our team of highly organized editors whose efforts have made the prompt publication of this volume possible.

**Barry L. Nestel**  
*Associate Director*  
*Agriculture, Food and Nutrition Sciences Division, IDRC*

**COUNCIL**  
**of the**  
**INTERNATIONAL SOCIETY FOR**  
**TROPICAL ROOT CROPS**  
**1976-79**

<b>President</b>	D. L. Plucknett (USA)
<b>Vice-Presidents</b>	L. Degras (Guadelupe) (Regional affairs) H. D. Thurston (USA) (Fund-raising) J. Madamba (Philippines) (Fifth symposium)
<b>Secretary</b>	M. R. Villanueva (Philippines)
<b>Treasurer</b>	B. L. Nestel (U.K.)
<b>Councillors</b>	N. Hrishi (India) L. Lujan (Colombia) B. N. Okigbo (Nigeria) L. A. Wilson (Trinidad)

## **Welcoming Address on behalf of the Government of Colombia**

**Dr Josue Franco M.**

*Director General  
Instituto Colombiano Agropecuario (ICA)*

The presence of recognized specialists at this symposium has a special meaning to Colombia, since edible root crops have always been a basic component of the staple diet of our people. Indeed the discovery in tropical America of food crops such as potatoes, cassava, sweet potatoes, yams, arracacha, malanga, sago, achira and others, dates back to the time of Columbus. However, improved technology has only developed in recent years as a result of population increases and worldwide food shortages.

Of those crops mentioned, potatoes have received the most attention. Scientists have studied them for more than a century because they passed the tropical and subtropical barriers and adapted to temperate soils. After the tragic famines in Ireland following the failure of potato crops in the last century, methods and systems to increase and stabilize potato production were designed.

Nowadays yams are regarded with particular interest because of the presence in some varieties of corticoid substances with widely known medicinal uses. Let us hope that the other plants you are studying with such dedication will contain equally important elements that will gain public attention, in addition to meeting the food needs of an ever-increasing population.

I think that the basic problem of the crops you are discussing here at this symposium is not so much the production of dry matter, but that of low protein content and poor quality. The percentage protein content of some root crops barely exceeds 2%. In experimental trials, ICA has obtained yields of 40–60 tons/ha from both cassava and potatoes. This illustrates the large potential that exists for increasing carbohydrate production. The same is true for yams, whose production can range from 20 to 30 tons/ha, although they have been subjected to relatively little scientific study. As you see, it is easier to solve the caloric deficit than the protein one. Thus, the efforts being made to produce cassava by-products with a high protein content through microbiological fermentation deserve further attention, and stress the need for new areas of research in the field of food technology.

The World Food Council has expressed the hope that “after ten years (1975–1985) no child will go to bed hungry, no family will lack their daily bread, and no human being will be restricted by malnutrition in the future.” However, increased crop production will only occur if there is a good economic return. In turn, this depends not only on the available technology but on the way it is applied, within a given economic and political framework.

I would like to mention that for the social, economic, and regional development of Colombia (1975–1985) considerable importance has been placed on a new Nutrition and Food Plan (PAN) which is part of the government's Integrated Rural Development Programs (DRI). The objectives of the Plan are to increase food production and to encourage better nutrition among consumers. Hopefully the knowledge gained at this symposium will reinforce existing technology so that it may better meet the needs of tropical countries.

For us, the symposium has still another attraction. In Colombia, roots and tuber crops, with the partial exception of potatoes, are produced mainly by small farmers. The adoption of new technology has proved to be very difficult in the traditional small farm sector, and the Colombian Government has given top priority to this issue.

---

## **Welcoming Address on behalf of the Food and Agriculture Organization of the United Nations**

**Dr H. A. Al-Jibouri**

*Senior Officer, Field Food Crops Group  
Plant Production and Protection Division  
FAO, Rome, Italy*

On behalf of the Food and Agriculture Organization, I am honoured to attend this symposium, and to extend the most sincere and warm wishes of the Director-General of FAO, Mr Edouard Saouma, for the success of this gathering.

Furthermore, I am particularly pleased to convey the enthusiasm and support of Dr Felix Albani, Director of the Plant Production and Protection Division, who has made it possible for several of his staff members to participate in and contribute to this meeting.

FAO is very pleased to be associated with this symposium, and has actively participated in the previous ones. Delegates may be interested to know of FAO's activities in the field of tropical root crop production and improvement since the Third Symposium. With financial aid from the United Nations Development Programme (UNDP), FAO was able to place a number of field experts in developing countries of the South Pacific, Asia, and Africa, to assist in programs related to the breeding, agronomy, and protection of root crops. UNDP has agreed, in principle, to provide more than US \$700 000 for a regional project on "Root crops development in the South Pacific." Another inter-country project for Africa entitled "Network of research stations on root and tuber crops" is also under consideration by the UNDP. Two publications, one on "Cassava — its importance in tropical countries" and the other on "Cassava processing" are in preparation by FAO and will shortly be published.

In the field of exchange of disease-free planting material FAO's role is to facilitate the shipment of such material from one country to another. Promotion of a network for genetic resources conservation centres, which include tropical root crops, is also one of FAO's regular program activities. A survey of root crops production and improvement in six countries located in the humid tropics of Asia was completed in 1974. A consultant was recruited in 1975 to prepare suggestions and guidelines for FAO's role in increasing and improving the productivity of tropical root crops in developing countries.

In many developing countries root crops are important energy sources which are easy to produce and which may have a processing or an export potential. To increase its support for root crop production especially in the tropics, FAO added a specialist in this field to its headquarters staff in 1976.

## **Welcoming Address on behalf of the International Society for Tropical Root Crops**

**D. G. Coursey**

*Tropical Products Institute  
56-62 Gray's Inn Road, London, England*

At the end of my term as President, it is an honour and a pleasure to welcome you on behalf of the International Society for Tropical Root Crops to this fourth International Symposium. This is the first truly international symposium on tropical root crops held in Latin America and it is most appropriate that Colombia is the host country. Other Latin American countries may have a higher production and utilization of tropical roots than Colombia, but this is probably the country of origin of one of the most important root crops — cassava. If the historians are not wrong, it was near this meeting place that cassava was first domesticated by man. Therefore, it is reasonable to expect that this symposium will devote considerable attention to cassava. But, we also find yam in Colombia, particularly in the coastal regions, while potatoes, sweet potatoes, ocumo, and other crops of the aroid group are abundantly produced here.

Colombia being the host country, it is most appropriate for the symposium to be organized in the magnificent facilities of CIAT, one of the newest institutions among those devoted to international research on agriculture. CIAT has started the most ambitious research program ever on cassava improvement, which although still young, already shows signs of great success, as in the case of the rice and wheat programs of the older international centres.

However, while looking ahead during the deliberations in this symposium, we should not forget the part which made possible our present development. It is nearly a decade since the first Symposium on Tropical Root Crops was held in April 1967 at the University of the West Indies in Trinidad. That was also the year in which, by coincidence, the classical study on production potential of tropical roots by de Vries, Ferweda, and Flach was published, attracting the attention of agricultural scientists to these long-neglected crops. Through this decade the attitude toward tropical roots has changed considerably in most countries of the world, and they are now more widely recognized as important producers of food both for humans and for animals.

We should be grateful for the foresight displayed by the organizers of the 1967 symposium, although I am sure they could not have anticipated how rapidly the subject would develop. That first symposium was a great success, and the participants realized the value in organizing another meeting and forming an association to maintain the contacts and interest.

As a result, the second International Symposium was held in August 1970 at the University of Hawaii. At that meeting the International Society for Tropical Root Crops was formally created, and it has subsequently made a great impact on the world of tropical agriculture. Ibadan, Nigeria, was the host of the third International Symposium on Tropical Root Crops in December 1973, organized by the Society with the cooperation of the International Institute of Tropical Agriculture.

I would like to express our appreciation to CIAT for having offered its premises and facilities for this gathering. I also want to thank the Colombian government for its hospitality and help which have made this symposium possible. We are grateful as well to the authorities of Cali and Palmira and especially to the organizations which have financially supported the Symposium: CIAT, USAID, and IDRC, whose help has enabled many young scientists from developing countries to attend this symposium.

## Participants

- Adam, Clifford S.** Ministry of Agriculture, Fisheries and Food, Grand Anse Mahé Experimental and Food Production Centre, P.O. Box 166, Mahé, Seychelles, Indian Ocean
- Adegbola, Anthony A.** University of Ife, Nigeria and CIAT, Apartado Aéreo 67-13, Cali, Colombia
- Aguirre R., Gustavo** Federación Nacional de Cafeteros, Calle 14 #7-36, Piso 6º, Bogotá, D.E., Colombia
- Al-Jibouri, Hazim Ahmed** Plant Production and Protection Division, Food and Agriculture Organization of the United Nations, via Delle Terme de Caracalla, Rome, 00100, Italy
- Allem, Antonio Costa** CENARGEN/EMBRAPA, Caixa Postal 102372, 70.000 Brasília, D.F., Brasil
- Amaya, Alvaro** Centro Internacional de Agricultura Tropical, CIAT, Apartado Aéreo 67-13, Cali, Colombia
- Arias, Bernardo** Centro Internacional de Agricultura Tropical, CIAT, Apartado Aéreo 67-13, Cali, Colombia
- Arteaga, Luis Ignacio** Unión de Bananeros de Uraba, S.A., Calle 51 #48-9, Oficina 801, Medellín, Antioquia, Colombia
- Bandhukul, Rangsit** Centro Internacional de Agricultura Tropical, CIAT, Apartado Aéreo 67-13, Cali, Colombia
- Bello R., Carlos N.** Banco Central de la República Dominicana, Apartado 1347, Calle Pedro Henriquez, Ureña Esq. Leopoldo Navarro, Santo Domingo, Rep. Dominicana
- Bellotti, Anthony** Centro Internacional de Agricultura Tropical, CIAT, Apartado Aéreo 67-13, Cali, Colombia
- Blanco B., Nelson** MOP CODESUR, Torre Diamen — 2º Piso, Apto. Postal 4824, Caracas, 101, Venezuela
- Best, Philip Rupert** Tropical Products Institute/CIAT, Apartado Aéreo 67-13, Cali, Colombia
- Booth, Robert H.** Tropical Products Institute, c/o MARDI, Beg Berkunci 202, Pejabat Pos, Universiti Pertanian Malaysia, Serdang, Selangor, West Malaysia
- Botero S., Rodrigo** Federación Nacional de Cafeteros de Colombia, Apartado Aéreo 3938, Bogotá, D.E., Colombia
- Bourdoux, P.** Department of Radioisotopes, Hopital Saint Pierre, University of Brussels, Rue Haute 322, B-1000-Brussels, Belgium
- Cadavid L., Luis F.** Centro Internacional de Agricultura Tropical, CIAT, Apartado Aéreo 67-13, Cali, Colombia
- Caesar, Knud** Technical University of Berlin, Institute of Crop Science, Albrecht Thaer Weg 5, 1000 Berlin 33/ Germany
- Calderon, Humberto** Centro Internacional de Agricultura Tropical, CIAT, Apartado Aéreo 67-13, Cali, Colombia
- Carpena, Azucena L.** Institute of Plant Breeding, University of the Philippines at Los Baños, College, Laguna, Philippines
- Castaño, Jairo** Centro Internacional de Agricultura Tropical, CIAT, Apartado Aéreo 67-13, Cali, Colombia

- Castro-Merino, Abelardo** Centro Internacional de Agricultura Tropical, CIAT, Apartado Aéreo 67-13, Cali, Colombia
- Celis, Ernesto** Centro Internacional de Agricultura Tropical, CIAT, Apartado Aéreo 67-13, Cali, Colombia
- Cock, James H.** Centro Internacional de Agricultura Tropical, CIAT, Apartado Aéreo 67-13, Cali, Colombia
- Coursey, D. G.** Tropical Products Institute, 56-62 Gray's Inn Road, London WC1X 8LU, United Kingdom
- Covington, Henry** North Carolina State University, Box 5155, Raleigh, North Carolina, 27607, USA.
- Chan, Seak Khen** Malaysian Agricultural Research and Development Institute, MARDI and CIAT, Apartado Aéreo 67-13, Cali, Colombia
- Chandra, S.** Research Division, Department of Agriculture, Suva, Fiji
- Charles, Arthur E.** Department of Primary Industry, P.O. Box 2417, Konedobu, Papua New Guinea
- Christiansen G., Jorge A.** The International Potato Center, CIP, Apartado Postal 5969, Lima, Peru
- Dahmani, Boneid W.** Faculty of Agriculture, University of Tripoli, Alfath, Libya
- Dahniya, Mohamed T.** University of Sierre Leone, Njala University College, Private Mailbag, Freetown, West Africa
- Dharmaputra, T. S.** Brawijaya University, Jl. Raya Dieng 2 A, Malang, Indonesia
- Daza B., Pablo E.** Centro Internacional de Agricultura Tropical, CIAT, Apartado Aéreo 67-13, Cali, Colombia
- De Bruijn, Gerard H.** Agricultural University, Department of Tropical Crop Science, Ritzema Bosweg 32, Wageningen, The Netherlands
- Degras, Lucien** Centre de Recherches Agronomiques des Antilles et de la Guyana, (INRA, France), Station d'amélioration des Plantes, Domaine Duclos 97170, Petit-Bourg, Guadeloupe
- Delange, Francois** Service des Radioisotopes, Hopital Saint-Pierre, University of Brussels, 322 Rue Haute, 1000 Brussels, Belgium
- Diaz, Rafael Orlando** Centro Internacional de Agricultura Tropical, CIAT, Apartado Aéreo 67-13, Cali, Colombia
- Ene, Leonard Samuel O.** National Root Crops Research Institute, Umudike, Umuahia (Imo State), Nigeria, P.M.B. 1006, Umudike
- Enyi, B. A. C.** Faculty of Agriculture, University of Papua, P.O. Box 4820, Port Moresby, Papua New Guinea
- Estrada, Nelson** CIP, Apartado Postal 5969, Lima, Peru
- Ezeilo, Walter** International Institute of Tropical Agriculture, IITA, P.M.B. 5320, Ibadan, Nigeria
- Ezumah, Humphrey Ch.** International Institute of Tropical Agriculture, IITA, P.M.B. 5320, Ibadan, Nigeria
- Ferguson, Theodore U.** Caribbean Development Bank, P.O. Box 408, Wildey, St. Michael, Barbados
- Fiesta, Donald** AID, ROCAP, U.S. Embassy, Ciudad de Guatemala, Guatemala
- Freire Goncalves, Wania M.** EMBRAPA, Bahía, Brazil and CIAT, Apartado Aéreo 67-13, Cali, Colombia
- Fukuda, Chigeru** EMBRAPA, Bahía, Brazil and CIAT, Apartado Aéreo 67-13, Cali, Colombia
- Garcia P., Samuel** Federación Nacional de Cafeteros, Banco Cafetero — Oficina Principal, Piso 4º, Cali, Colombia
- Gartner, Jairo** Instituto Colombiano, Agropecuario, ICA, Apartado Aéreo 233, Palmira, Valle, Colombia
- Giraldo C., Roberto** Federación Nacional de Cafeteros, Apartado Aéreo 3938, Bogotá, D.E., Colombia

- Gomez C., Pedro Leon** Instituto Colombiano Agropecuario, ICA — Tibaitatá, Apartado Aéreo 151123, "El Dorado", Bogotá, D.E., Colombia
- Gomez, Guillermo** Centro Internacional de Agricultura Tropical, CIAT, Apartado Aéreo 67-13, Cali, Colombia
- Graham, Michael** International Development Research Centre, IDRC, P.O. Box 8500, Ottawa, Canada K1G 3H9
- Gross, H. D.** Department of Crop Science, North Carolina State University, Box 5155, Raleigh, North Carolina, 27607, USA.
- Guillen, Ruben** Facultad de Agronomía, Universidad Central de Venezuela, Calle Miguel Peña, 95-60, Urbanización El Trigal, Valencia, Venezuela
- Habit, Mario A.** FAO Regional Office, Casilla 10095, Santiago, Chile
- Hahn, Sang Ki** International Institute of Tropical Agriculture, IITA, P.M.B. 5320, Ibadan, Nigeria
- Harris, Noel Vincent** Fielders Limited, P.O. Box 1034, Bundaberg, Queensland 4670, Australia
- Hemeng, Barbara M. S.** Department of Crop Production, Faculty of Agriculture, University of Science and Technology, Kumasi, Ghana, West Africa
- Holguin, Julio** Centro Internacional de Agricultura Tropical, CIAT, Apartado Aéreo 67-13, Cali, Colombia
- Holmes, E. B.** Department of Crop Science, University of West Indies, St. Augustine, Trinidad
- Holmquist, Juan de Dios** Facultad de Agronomía, Universidad Central de Venezuela, Maracay, Venezuela
- Howeler, Reinhardt** Centro Internacional de Agricultura Tropical, CIAT, Apartado Aéreo 67-13, Cali, Colombia
- Hrishi, N.** Central Tuber Crops Research Institute, Triandrum-17, India
- Hutagalung, R. I.** Faculty of Agriculture, University of Malaya, Kuala Lumpur 22-11, Malaysia
- Jaramillo, Gustavo** Centro Internacional de Agricultura Tropical, CIAT, Apartado Aéreo 67-13, Cali, Colombia
- Irikura, Yukio** Centro Internacional de Agricultura Tropical, CIAT, Apartado Aéreo 67-13, Cali, Colombia
- Jarupat, Thanakorn** Kasetsart University, Bangkok, Thailand, CIAT, Apartado Aéreo 67-13, Cali, Colombia
- Jeffers, John P.** Ministry of Agriculture, Science and Technology, P.O. Box 505, Bridgetown, Barbados
- Kawano, Kazuo** Centro Internacional de Agricultura Tropical, CIAT, Apartado Aéreo 67-13, Cali, Colombia
- Khajareern, Sarote** Animal Science Department, Faculty of Agriculture, Khon Kaen University, Khon Kaen, Thailandia
- Kobayashi, Masashi** Kyushu National Agricultural Experiment Station, 1340, Jitcho, Ibusuki-shi, Kagoshima-ken, Japan 891-04
- Laberry, Rafael** Universidad Nacional Técnica de Piura-Perú/CIAT, Apartado Aéreo 67-13, Cali, Colombia
- Lan Geh, Swee** MARDI/CIAT, Apartado Aéreo 67-13, Cali, Colombia
- Larios C., Joaquin F.** Facultad de Ciencias Agronómicas, Departamento de Parasitología Vegetal, Universidad de El Salvador, Apartado Postal 773, San Salvador, El Salvador, C.A.
- Leon, Jorge** Programa de Germoplasma, CATIE, Turrialba, Costa Rica
- Leu, L. S.** Plant Protection Center, 189 Chung Cehng Road, Wufeng, Taichung Hsien, Taiwan 431, Republic of China
- Lezama R., Alfredo Jose** Ministerio de Obras Públicas, MOP CODESUR, Torre Diamen — 2º Piso, Redoma de Chuao, Caracas, Venezuela

- Loomis, Robert S.** Department of Agronomy and Range Science, College of Agricultural and Environmental Sciences, Agricultural Experiment Station, University of California, Davis, California 95616, USA.
- Lozano, J. Carlos** Centro Internacional de Agricultura Tropical, CIAT, Apartado Aéreo 67-13, Cali, Colombia
- Lujan, Lauro** ICA, Apartado Aéreo 151123 "El Dorado", Bogotá, D.E., Colombia
- MacIntyre, L. Reginald** International Development Research Centre, P.O. Box 8500, Ottawa, Canada K1G 3H9
- McCann, David J.** Department of Chemical Engineering, University of Sydney, Sydney 2006, Australia
- Malamud, Oscar S.** International Potato Center, CIP, Apartado 5969, Lima, Peru
- Marcano G., Luis** Fundación Servicio para el Agricultor, Establecimiento Experimental de Guara A/C CVG, Edificio Santa Inés, Calle Tucupita, Tucupita TFDA., Venezuela
- Marrewijk, Gijsbert A. M. van** Institute of Plant Breeding, Lawickse Allee 166, Wageningen, The Netherlands
- Martin, F. W.** Mayaguez Institute of Tropical Agriculture, Box 70, Mayaguez, Puerto Rico
- MacDonald, H. A.** Cornell University, Ithaca, New York, USA
- Martínez, Marcial** Hda. El Rosario Ltda., Calle 36 No. 24-23, Palmira, Valle, Colombia
- Mattos C., Luz Leonor** Universidad Nacional Agraria, "La Molina", Perú/CIAT, Apartado Aéreo 67-13, Cali, Colombia
- Mattos, Pedro Luiz Pires de** Centro Nacional Pesquisa de Mandioca e Fruticultura/EMBRAPA, Rua Ruy Barbosa 715, 44.380 — Cruz Das Almas — Bahía, Brasil
- Meera Hussain, Khelikuzaman** Malaysian Agriculture Research Development Institute and CIAT, Apartado Aéreo 67-13, Cali, Colombia
- Mendoza, H. A.** International Potato Center, CIP, Apartado 5969, Lima, Peru
- Montaldo, Alvaro** Universidad Central de Venezuela, Apartado 97, Maracay, Venezuela
- Montilla S., Juan J.** Departamento de Producción Animal, Facultad de Ciencias Veterinarias, Universidad Central de Venezuela, Apartado No' 4563, Maracay, Edo. Aragua, Venezuela
- Moyer, James W.** Department of Plant Pathology, North Carolina State University, Raleigh, North Carolina 27607, USA
- Mukiibi, J.** Department of Crop Science, Makerere University, P.O. Box 7062, Kampala, Uganda
- Nakayama, Tommy** Department of Food Science, University of Hawaii, 1920 Edmondson Road, Honolulu, Hawaii 96822, USA
- Nartey, Fred** Institute of Plant Physiology, University of Copenhagen, Ø. Fari-magsgade 2A, 1353 Copenhagen, Denmark
- Nestel, Barry L.** International Development Research Centre, IDRC, Apartado Aéreo 53016, Bogotá, D.E., Colombia
- Nassar, Nagib M. A.** Instituto de Ciencias Biologicas, Universidade Federal de Goias, Caixa Postal 591, 74.000 — Goiania, Goias, Brasil
- Nilmanee, Sanay** Centro Internacional de Agricultura Tropical, CIAT, Apartado Aéreo 67-13, Cali, Colombia
- Ninan, C. A.** Department of Botany, University of Kerala, Kariavattom, Trivandrum, India
- Nitis, I. M.** Faculty of Veterinary Science and Animal Husbandry, Udayana University, Denpasar, Bali, Indonesia
- Ngongi, A. G. N.** Soil Research Institute, Kwadaso, Kumasi, Ghana
- Obigbesan, Gabriel O.** Department of Agronomy, University of Ibadan, Ibadan, Nigeria
- Oke, Olusegun L.** Chemistry Department, University of Ife, Ile-Ife, Nigeria

- Okigbo, B. N.** International Institute of Tropical Agriculture, IITA, Oyo Road, P.M.B. 5320, Ibadan, Nigeria
- Omole, Adebowale T.** Department of Animal Science, University of Ife, Ile-Ife, Nigeria
- Osorio, Jorge Alberto** Ministerio de Agricultura y Cría, Dirección de Sanidad Vegetal, Torre Norte, Centro Simón Bolívar, Caracas 101 — Venezuela
- Pais, Endy** LAES, Department of Primary Industry, P.O. Keravat, East New Britain, Papua New Guinea
- Parra, German** Centro Internacional de Agricultura Tropical, CIAT, Apartado Aéreo 67-13, Cali, Colombia
- Passos, Orlando Sampaio** Centro Nacional de Pesquisa de Mandioca e Fruticultura/ EMBRAPA, 44380 Cruz Das Almas, Bahía, Brasil
- Perez R., German** Politécnico Colombiano — Medellín, Calle 35 No. 78A-23, Apartado Aéreo 52092, Medellín, Antioquia, Colombia
- Perez, Octavio** Instituto Colombiano Agropecuario, ICA, Apartado Aéreo 51764, Medellín, Antioquia, Colombia
- Persley, Gabrielle J.** International Institute of Tropical Agriculture, IITA P.M.B. 5320, Ibadan, Nigeria
- Phillips, Truman P.** School of Agricultural Economics, University of Guelph, Guelph, Ontario, Canada
- Plucknett, Donald L.** Office of Agriculture, Technical Assistance Bureau, Agency for International Development, AID, Washington, D.C. 20523, USA
- Pulido, Jorge** Oficina Planeamiento, Sector Agropecuario, OPSA, Ministerio de Agricultura, Bogotá, D.E., Colombia
- Rankine, Lloyd B.** Department of Agricultural Economics, University of the West Indies, St. Augustine, Trinidad
- Ramirez G., Esteban** PROTINAL-Venezuela and CIAT, Apartado Aéreo 67-13, Cali, Colombia
- Rice, Edward** Crops Production Agriculture, Bureau Technical Assistance, USAID, Washington, D.C., USA
- Rios R., Mario** Instituto Colombiano Agropecuario, ICA, Apartado Aéreo 654, Santa Marta, Magdalena, Colombia
- Rodrigues, Roberto A.** EMATER, M. G., Avenida Dos Andradas No. 367, Caixa Postal 900, Belo Horizonte, Minas Gerais, Brasil
- Rojanaridpiched, Chareinsuk** Kasetsart University, Thailand and CIAT, Apartado Aéreo 67-13, Cali, Colombia
- Romero T., Oscar A.** Productos Agropecuarios S.A., PROASA, Calle 72 Esq. Av. 19, Ed. Noel, 3º Piso, Apto. 8, Maracaibo, Venezuela
- Rosero R., Alvaro** Asociación de Bananeros y Agricultores de Urabá — AUGURA, Apartado Aéreo No. 216, Apartadó — Antioquia, Colombia
- Sadik, S.** International Institute of Tropical Agriculture, P.M.B. 5320, Ibadan, Nigeria
- Samlal, Ramsarup** Agricultural Experiment Station, P.O. Box 160, Paramaribo, Surinam
- Sanchez, Carlos Roberto** Universidad del Tolima, Carrera 7a. #11-56, Espinal, Tolima, Colombia
- Sanin Bermudez, Ober** Federación Nacional de Cafeteros, Carrera 22 #63-77, Manizales, Caldas, Colombia
- Santos N., Jorge** Centro Internacional de Agricultura Tropical, CIAT, Apartado Aéreo 67-13, Cali, Colombia
- Sayre, Kenneth O.** The International Potato Center, CIP, Apartado 5969, Lima, Peru
- Seif, Abdurabi A.** Coast Agricultural Research Station, P.O. Box 16, Kikambala Via Mombasa, Kenya

- Sidhu, Ajit Singh** Malaysian Agricultural Research and Development Institute, MARDI, Serdang, Selangor, Malaysia
- Sykes, John Trevor** IBPGR Secretariat, Plant Production and Protection Division, Food and Agriculture Organization of the United Nations (FAO), Via delle Terme di Caracalla, 00100, Rome, Italy
- Tan, Swee Lian** MARDI, Malaysia and CIAT, Apartado Aéreo 67-13, Cali, Colombia
- Tanaka, Jack S.** Department of Horticulture, University of Hawaii, 3190 Maile Way, Honolulu, Hawaii 96822, USA
- Teri, James M.** Centro Internacional de Agricultura Tropical, CIAT, Apartado Aéreo 67-13, Cali, Colombia
- Terry, E. R.** International Institute of Tropical Agriculture, IITA, P.M.B. 5320, Ibadan, Nigeria
- Thompson, John R.** BARTAD Project, San Andros P.O., N. Andros Island, Bahamas
- Thung, Michael** Centro Internacional de Agricultura Tropical, CIAT, Apartado Aéreo 67-13, Cali, Colombia
- Thurston, H. David** Department of Plant Pathology, Cornell University, Ithaca, New York 14853, USA
- Tiraporn, Charn** Centro Internacional de Agricultura Tropical, CIAT, Apartado Aéreo 67-13, Cali, Colombia
- Tlaskal, J. G.** CSR Research Laboratories, P.O. Box 39, Roseville, N.S.W., Australia
- Torio, J. C.** International Rice Research Institute, IRRI, P.O. Box 933, Manila, Philippines
- Toro, J. Cesar** Centro Internacional de Agricultura Tropical, CIAT, Apartado Aéreo 67-13, Cali, Colombia
- Toure, Bakary** University of Abidjan, Faculty of Sciences, B.P. 4322, Abidjan, Ivory Coast
- Trujillo, Freddy** Centro Internacional de Agricultura Tropical, CIAT, Apartado Aéreo 67-13, Cali, Colombia
- Umanah, E. E.** Federal Department of Agricultural Research, Private Mail Bag 5042, Ibadan, Nigeria
- Valdes S., Hugo** Federación Nacional de Cafeteros de Colombia, Programa de Desarrollo y Diversificación de Zonas Cafeteras, Apartado Aéreo 30244, Bogotá, D.E., Colombia
- Vargas P., Angelino** Carrera 70A No. 63-12, Bogotá, D.E., Colombia
- Vargas, Ruben E.** Facultad de Ciencias Veterinarias, Universidad Central de Venezuela, Apartado de Correos No. 4563, Maracay 2, Edo. Aragua, Venezuela
- Varghese, George** Agricultural University of Malaysia, Serdang, Selangor, Malaysia
- Varon, Uldarico** Centro Internacional de Agricultura Tropical, CIAT, Apartado Aéreo 67-13, Cali, Colombia
- Velez, Julian** Compañía Frutera de Sevilla, Apartado Aéreo 50309, Medellín, Antioquia, Colombia
- Vergara, Nestor** Oficina de Planeamiento, Ministerio de Agricultura, Carrera 10 No. 20-30, Oficina 702, Bogotá, D.E., Colombia
- Versteeg, Mark N.** Proyecto Coperholta, Ministerio de Alimentación, Apt. 102, Tarapoto, Peru
- Vichukit, Vichan** Kasetsart University, Bangkok-9, Thailand, CIAT, Apartado Aéreo 67-13, Cali, Colombia
- Villanueva, M. R.** National Root Crops Research Center, Baybay, Leyte 7127, Philippines
- Vries, C. A. De** Department of Agricultural Research, Royal Tropical Institute, Mauritskade 63, Amsterdam, Netherlands

- Wahab, Abdul** Guyana Sugar Corporation Ltd., Project Evaluation Unit, 22 Church St., Georgetown, Guyana
- Ward, Anne** Centre for Overseas Pest Research, College House, Wrights Lane, London W8 5SJ, United Kingdom
- Warid, Warid A.** College of Agriculture, University of Tripoli, P.O. Box 2547, Tripoli, Libya
- Weir, Cynthia** Crops and Soils Division, Ministry of Agriculture, P.O. Box 480, Kingston, Jamaica
- Wholey, Douglas W.** MARDI/IDRC Cassava Project, Field Crops Branch, MARDI, Beg Berkunci 202, Pejabat Pos, University Pertanian Malaysia, Serdang, Selangor, W. Malaysia
- Wilson, Graeme L.** Department of Agriculture, University of Queensland, St. Lucia, Queensland 4067, Australia
- Wilson, L. A.** Department of Crop Science, University of the West Indies, St. Augustine, Trinidad, W.I.
- Wilson, L. G.** Department of Horticultural Science, North Carolina State University, Raleigh, North Carolina 27607, USA
- Wood H., Rogelio** Banco Nacional de Crédito Rural, Avda, Coyoacán 318, México 13, D.F., Mexico
- Wright, Madison** Department of Agronomy, Box 3, Bradfield Hall, Cornell University, Ithaca, New York 14853, USA
- Wurster, Richard** The International Potato Center, CIP, Apartado 5969, Lima, Peru
- Yaseen, Maajid** Commonwealth Institute of Biological Control, Gordon Street, Curepe, Trinidad, W.I.



## **Section 1. Origin, Dispersal, and Evolution**

- 20 Origin, evolution, and dispersal of root and tuber crops **Jorge León**
- 36 Giant swamp taro, a little-known Asian-Pacific food crop **Donald L. Plucknett**
- 40 A review of sexual propagation for yam improvement **Sidki Sadik**
- 44 Selected yam varieties for the tropics **Franklin W. Martin**
- 50 Preliminary results on the adaptation of cultivated potatoes to the lowland tropics  
**H. A. Mendoza**
- 53 Sweet potato breeding using wild related species **Masashi Kobayashi and  
Tsukasa Miyazaki**
- 58 Vegetative and sexual management in food yam production **L. Degras**
- 62 Sweet potato clones adapted for Libyan agriculture **Warid A. Warid,  
Boleid W. Dahmani, and Moshab M. Kushad**
- 65 Summary of Discussions **D. Plucknett**

# Origin, Evolution, and Early Dispersal of Root and Tuber Crops

Jorge León<sup>1</sup>

Tropical root and tuber crops have been domesticated in Southeast Asia, west-central Africa, and tropical Latin America (including the high Andes). The crops belong to different families. Species of the one genus (*Dioscorea*) were domesticated independently in each of the three regions. Species of *Colocasia* and *Xanthosoma* (family Araceae) and *Pachyrrhizus* and *Pueraria* (family Leguminosae) were domesticated in separate regions. Many of these crops have restricted areas of distribution due to physiological requirements and are becoming relict crops.

Roots and tubers are ancient crops, and even today support groups of people who gather them from wild plants. Poisonous, acrid, or bitter qualities were found in the most important crops by early man, who learned how to remove or destroy these undesirable qualities. Most of the root and tuber crops are polyploids, and most of them are vegetatively propagated. Fertility traits are therefore of special importance in their evolution under cultivation, but there is no evidence that clonal propagation has led to sterility. Information on their evolution is extremely scarce as cultural sources, archaeological, linguistic, and historic information is scanty and unevenly distributed. On biological sources, comparative taxonomy, metaphase cytology, and hybridization have given some important clues, but there is still very little information available on the evolution of these species.

Root and tuber crops dispersed slowly between Southeast Asia and Africa. After the seventeenth century a very active interchange occurred especially with the American crops. Since then, there has been a continuous replacement of crop species, especially in Africa. The sweet potato, of American origin, was found in Oceania when the Europeans arrived, but no satisfactory explanation of how it got to Polynesia has ever been made.

Root and tuber crops are thought to be of ancient origin, and are often regarded as relics of primitive agriculture. This concept is based on the important role these crops play in existing primitive societies, and on the rudimentary husbandry they require, particularly vegetative propagation. These crops are easily adapted in the less-advanced agricultural systems because of their high yields, resistance and earliness, and in the dietary pattern by their bulk and taste qualities.

Since the last century, geographers and anthropologists have contrasted root and tuber production, which includes other clonally propagated crops such as bananas, breadfruit, sugarcane, with seed agriculture. Vegetative propagation, developed in tropical regions, is assumed to be a static system, whereas seed agriculture is associated with the development of more advanced societies. Geographers and historians are tempted to associate "civiliza-

tion" with cereals. In vegetative propagation primitive farmers apply simple husbandry, but the same is true when they grow seed crops. On the other hand, some vegetative crops, such as potatoes, have reached an advanced stage of production and technology, comparable to many other crops. The view persists, however, that vegetative propagation represents a low stage of progress, and a distinguished cytogeneticist in his interpretation of history (Darlington 1969), points to "the fatal abundance of tropical root crops imported from Asia and America" as one of the main factors in the decline of Africa.

The contrasting of agricultural systems based on the differences between seed and clonal propagation is a simplification of a problem that is too complex to be reduced to the duality of planting materials.

## The Basic Materials

Roots and tubers are storage organs that are developed in many families of plants, probably as a result of selective pressures in environ-

<sup>1</sup>Programa de Germoplasma, CATIE, Turrialba, Costa Rica.

ments with varying amounts of rain. The storage organs permit the accumulation of nutrients elaborated by the aerial parts of the plant. By growing underground, they maintain the nutrients with minimal loss. Once the temporary branches or foliage have dried, new shoots develop from the storage organs. By harvesting roots and tubers before the plants have flowered, man has interrupted this process, and has thus kept the plants in a kind of permanent juvenile stage.

Although storage organs may vary in their phylogeny and structure, the nature of their storage tissues is common. These organs are large masses of parenchyma that contain mainly water and starch grains. The parenchyma is intimately connected with the vascular system, which permits easy transport from and to the storage organs. Frequently, there are poisonous, bitter, or acrid substances in the storage tissues, which present an obstacle to the utilization of roots and tubers. However, these substances are a deterrent to animals and therefore play an important role in the survival of plants growing in natural conditions. The quantity of these materials (e.g. raphides or glucosides) varies considerably within the same species, a trait that is mainly determined by inherent factors.

The storage organs may be roots or stems. In roots, such as cassava, the storage tissues may derive from a normal cambium, or as in the sweet potato from tertiary cambiums that develop around vascular elements. Storage stems are of different kinds (e.g. rhizomes, tubers, and corms), and as in roots, the storage tissues may derive from different types of cambium. In most of the root and tuber crops, storage organs are more than carbohydrate sinks. They are also reproductive organs, and this double function has been of foremost importance in their propagation by man.

The common classification of crops by the utilization of certain organs results in artificial groupings. Thus, temperate species utilized for their roots or stems (radishes, beets) are considered as vegetables, whereas tuber crops yielding essential oils (ginger) are included among the spices. The present discussion is limited to tropical and subtropical species used mainly for their starch content as energy foods (Table 1).

### Factors in Evolution

The usual sources of biological information

on crop evolution — comparative taxonomy, cytological analysis especially at metaphase, and experimental hybridization — have been applied to some of the root and tuber crops. However, as a whole, the information available, with the possible exception of potatoes, is very poor and scattered.

Comparative taxonomy aims to establish the relationships among existing taxa with the cultivated species. The definition of their taxonomic position permits the identification of putative parents and the delimitation, within the genus, of the cluster of species more closely associated with the cultivated taxa. The traditional methods of taxonomy do not work well with root and tuber species. Often foliage is difficult to accommodate in herbarium sheets; flowers are bulky, fleshy, and frequently absent; root and tubers too difficult to preserve. In some genera, like *Xanthosoma*, the taxonomic status is extremely unsatisfactory; the abundant synonymy in the aroids and yams is, in part, a result of studies based on herbarium materials. As in other crops, the identification of a wild population closely related to the cultivated species, raises the question of whether it is an ancestor of the cultivated type or a feral or weedy form. In *Ullucus*, an aboriginal species has been described (Brucher 1962), but this could be only a wild variety. A hexaploid population of *Ipomoea* from Mexico, has been considered as an ancestor species (Nishiyama 1971) or a weedy variety of the sweet potato (Martin et al. 1974).

Cytological studies are interrelated with taxonomy and both have helped to solve some problems. But it is surprising how little is known in this field. Of some of the cultivated species there is no information even on chromosome number. On the other hand, some of the root tuber crops offer technical problems such as chromosome size and high number, which make it difficult to detect possible linkages or identification points.

There is a trend to attribute to interspecific hybridization the origin of most cultivated plants, especially if they are polyploids. In roots and tubers, sweet potatoes (Nishiyama et al. 1975), African yams (Ayensu and Coursey 1972), common potatoes (Dodds 1965), and others have been assigned such origin, and putative parents have been suggested for some of them. Genome identification lends some support to this contention, but it is very difficult to obtain definitive evidence from

Table 1. Tropical and subtropical species used mainly for their starch content as energy foods.

Monocotyledoneae		
Agavaceae	<i>Cordyline terminalis</i>	Ti, palm lily
Araceae	<i>Alocasia</i>	Ape, biga, birah
	<i>Amorphophallus</i>	Suran, elephant yam
	<i>Colocasia</i>	Taro
	<i>Cyrtosperma</i>	—
	<i>Xanthosoma</i>	—
Cannaceae	<i>Canna edulis</i>	Achira
Cyperaceae	<i>Cyperus esculentus</i>	—
	<i>Eleocharis tuberosus</i>	Water chestnut
Dioscoreaceae	<i>Dioscorea</i> (12 species)	Yam
Marantaceae	<i>Maranta arundinacea</i>	Arrowroot
	<i>Calathea allua</i>	Lairen
Taccaceae	<i>Tacca leontopetaloides</i>	Pia, Polynesian arrowroot
Zingiberaceae	<i>Curcuma angustifolia</i>	—
	<i>Curcuma zeodoaria</i>	—
Dicotyledoneae		
Basellaceae	<i>Ullucus tuberosum</i>	Ulluco
Compositae	<i>Polymnia sonchifolia</i>	Yacon
Convolvulaceae	<i>Ipomoea batatas</i>	Sweet potato
Cruciferae	<i>Lepidium meyenii</i>	Maca
Euphorbiaceae	<i>Manihot esculenta</i>	Cassava
Labiateae	<i>Plectranthus esculentus</i>	Kafir potato, dazo
	<i>Solenostemon rotundifolius</i>	Hausa potato
	<i>Stachys sieboldii</i>	—
Leguminosae	<i>Pachyrrhizus</i> (spp.)	Ahipa
	<i>Psyplocarpus tetragonolobus</i>	Sigarilla
	<i>Pueraria lobata</i>	—
	<i>Sphenostylis stenocarpa</i>	—
Oxaladaceae	<i>Oxalis tuberosa</i>	Oca
Solanaceae	<i>Solanum tuberosum</i>	Potato
Tropaeolaceae	<i>Tropaeolum tuberosum</i>	Mashua
Umbelliferae	<i>Arracacia xanthorrhiza</i>	Arracacha

hybridization work. Often the terms "nobilization" or "ennoblement" are applied to root and tuber crops, meaning improvement by primitive agriculturists. These terms imply a planned hybridization, as in sugar cane breeding, which is not the case in root and tuber crops. On the other hand, information obtained from hybridization aimed at crop improvement is rather incidental to crop evolution.

As a main force in evolution, the impact of recombination is possibly less evident now than in the past. Under original conditions, root and tuber species were closer to their primitive allies and hybridization may have been more frequent. But as man moved them to new environments, not only did the possibility for further crossing and segregation decrease, but the mechanisms of seed setting and sexual reproduction were affected. The practice of vegetative propagation helped to reduce the importance of segregation and increased the role

of somatic mutation in the evolution of these crops. However, hybridization in these crops is a potential force of considerable value for further improvement (Abraham et al. 1964).

### Polyploidy

As expected in cultivated crops, a good number of root and tuber crops have different ploidy levels. The early cytological studies on potatoes led to the separation of the numerous cultivars included in *Solanum tuberosum* into several species (Juzepczuk 1937), or into one species formed by five groups and two hybrids with other species (Dodds 1962). The cultivated diploids have been derived either from wild diploids, again with no total agreement on the identification of the ancestors, or from a primitive complex in which many diploid species may have taken part (Ugent 1970). The tetraploids may have arisen through allo-

polyploid or doubling of diploids (Simmonds 1976); the triploids as hybrids of tetraploids and diploids; and a pentaploid group from crosses between a triploid (unreduced gametes) and a tetraploid (Ugent 1970).

Perhaps the group of root and tuber crops in which polyploid is most complex is *Dioscorea*, but here again the studies have been scarce and isolated. In *D. alata*, a survey of chromosome numbers in Indian cultivars has established a series of  $2n = 30, 40, 50, 70$  for different clones that do not show phenotypical differences (Sharma and Deepesh 1956). Also polyploidy has been detected in this species, and this could be a possible source of new types through vegetative propagation. In *D. bulbifera*, there are morphological differences in the cultivated types of Africa and Asia, the former being considered by some authorities as a distinct species. Cytological counts tend to support such differences. The African cultivars have  $2n = 36, 40, 54, 60$  with a basic number  $lenta, 2n = 40, 90, 100$ ; *D. cayenensis*  $2n = 40, 60, 80, 100$  with a basic number of 20 (Martin 1974). Other polyploids are *D. esculenta*,  $2n = 40, 90, 100$ ; *D. cayennensis*  $2n = 140$ ; *D. opposita*  $2n = 40$ ; *D. penthaplylla*  $2n = 140$ . However, Coursey (1976) points out that in *Dioscorea* polyploidy is not restricted to cultivated species only.

In taro, a general survey of its variability is badly needed, as it is one of the most ancient of the root and tuber crops and one of the most widely spread. Two basic chromosome numbers have been recorded in taro,  $X = 12$  and  $X = 14$ . Clones with  $2n = 24$  and  $2n = 48$  are reported from India, while clones with  $2n = 28$  and  $2n = 42$  are found from India to Japan in one direction, and to Timor, New Caledonia, and New Zealand in the other. But east of  $180^\circ$ , that is in most of Polynesia, all clones show  $2n = 28$  (Yen and Wheeler 1968).

The most interesting example of polyploidy in root and tuber crops is the sweet potato, a hexaploid,  $2n = 90$ , which could be derived, as has been proved experimentally, in two ways: (1) by the multiplication of a diploid (*I. leucantha*), or (2) by the duplication of a triploid resulting from the crossing of a diploid (*I. leucantha*) and a tetraploid (*I. littoralis*). The resulting hexaploid, *I. trifida*, is considered a primitive form of *I. batatas* (Nishiyama 1971). As two of the three genomes in the sweet potato show more homology with each other than with the third (Magoon et al. 1970),

the second process is more likely to have occurred. Other species showing different levels of ploidy are: *Maranta arundinacea*, tetraploid; *Canna edulis*, triploid; *Ullucus tuberosus*, triploid; *Oxalis tuberosa*, hexaploid; *Tropaeolum tuberosum*, hexaploid. On the other hand, the cultivated *Xanthosoma* ( $X = 13$ ) are diploids,  $2n = 36$  (Plucknett 1976). Cassava,  $2n = 36$ , has been considered as a diploid (Magoon 1967) and as a tetraploid (Jennings 1976). In the Euphorbiaceae,  $X = 9$  is found in *Manihot* and allied genera, and the presence of three nucleolar chromosomes and some chromosome duplication at pachytene, suggest that cassava is possibly a segmental allotetraploid (Magoon et al. 1969; Jennings 1976).

There are several questions to consider in relation to polyploidy. For example, does it have any significance, as in other crops, on the size and quality of the useful parts of the plants. The information is meagre, except on potatoes, and in this crop it is masked by long selection, environmental conditions, and crop protection. There is no information, for instance, of any correlation in size of tubers and ploidy in the *Dioscorea alata* series mentioned above.

In triploids of *Canna edulis*, the starch content is almost three times higher than in the diploid, but there is no information on yield (Mukerjee and Khoshoo 1971). On the other hand, induced polyploids in cassava, assuming that it is a diploid, are not superior in yield to diploids. In *Ipomoea*, wild hexaploids do not show any root thickening, and therefore, the domestication character may result from processes other than polyploidy.

It is well known that most polyploids have a wide adaptability to new conditions. In cultivated polyploids, this characteristic aided by cultural practices, especially crop protection, is a key factor in their success and expansion.

Finally, an important aspect is to consider the possible relationships between polyploidy and vegetative propagation. Through the latter, a not fully balanced allopolyploid, for instance, could be multiplied and meiotic irregularities or gene-determined sterility bypassed. Such polyploids may spread, through clonal propagation, in a way that would be difficult through seed reproduction.

## Fertility and Vegetative Propagation

Vegetative propagation is necessary in most

root and tuber crops because of their inefficiency in producing seed, a result of natural and cultural factors. Among the natural factors are incompatibility, dichogamy, abnormal seed and seedling development, seed dormancy, and pests and diseases attacking flowers and seeds. Cultural factors are equally important. First, man has taken clonal crops to regions where environmental conditions do not favour seed setting. Second, plants are harvested when the storage organs have reached maturity, which occurs in most cases well before flower initiation. Third, man, by copying the same type (clone) in millions of individuals may have increased the possibilities, if a natural trait limiting fertility is present, to extend it into large populations.

It has been stated often, especially by non-biologists, that continuous vegetative reproduction leads to sterility. Sauer (1952) stated that cassava reproduction by cuttings has been carried out for so long that it has lost completely its ability to set seeds. Vegetative propagation in itself cannot lead to sterility although, as mentioned above, it may increase the frequency in a population of a trait favouring sterility, or has an indirect effect as it permits the cultivation in environments unfavourable for seed setting. However, some recent work in Nigeria shows that seed production is higher in yams coming from seed-producing plants than those obtained from tubers of continuous clonal propagation (Sadik and Obereke 1975). This could be due to the nature of the samples studied, but is worth further study. Some experimental work in cassava (Jennings 1963) showing different degrees of male and female sterility in hybrids and backcrosses may be partly due to the different materials used and to environmental effects.

As was said before, all root and tuber crops set seed. Reluctant clones are found, but experimental work shows that it may be possible to promote the formation of viable seed by changing environmental conditions or manipulating the flowering process. In cassava, flower induction has been obtained by moving plants to higher altitudes (above 1000 m in Java, Costa Rica, etc.) or in areas with special climatic conditions, such as the coast of central Peru, where most of the clones set seed regularly. In sweet potato, seed setting is reported from many countries (Yen 1974), often outside its natural area (e.g. the Philippines and Papua New Guinea). The scarcity of records of

seed production in taro (reports from Papua New Guinea, Rarotonga, Philippines) could be due to harvesting practices. In yams, seed setting is often limited by harvesting practices, but with some African species the constraints for sexual reproduction include a large number of male clones, imperfect seed, and dormancy periods. In potatoes, seed reproduction and factors conditioning low setting are well known, but even hybrids of induced haploids can set seeds under special conditions of temperature and air moisture (Subramanyan et al. 1972). All the Andean tubers produce abundant seeds. In oca (*Oxalis tuberosa*), however, seeds are extremely scarce in field conditions, but if protected from wind and frost, which produce abscission of the inflorescences, seed setting is normal (Alandia 1967). In arracacia, seeds are produced the second year but as the root matures in 8–14 months, flowers and seeds are rarely seen.

Vegetative propagation as a cultural practice is very important in the evolution of root and tuber crops. In modern agriculture, it permits the multiplication of superior and uniform materials in large monoclonal plantings. This leads to a continuous replacement of cultivars when superior clones become available, with consequent losses in germ plasm. In addition, monoclonal plantings may be wiped out quickly by diseases or pests. Vegetative propagation materials may become sinks of viruses and mycoplasma, and are subject to physiological degeneration also requiring clonal replacement. Under systems of primitive agriculture the effect of changes in planting materials is of less importance, as the standard practice is to plant several clones in the same plot, mixed or separated. Frequently the planting material is the edible part, and in time of scarcity or famine the "seed" has to be eaten. This double utilization made it possible for the Polynesians and possibly Incas to propagate as crops what they had brought as food for their long sea journeys.

As a whole, vegetative propagation, especially in monoclonal plantings, is an important restriction in increasing variability. In species of imperfect evolution, sexual reproduction is a second best choice in their reproductive system (Martin 1967).

### The Role of Mutation

In root and tuber crops, evolution through

chromosome or gene recombinations is limited by the predominance of vegetative propagation. Therefore, somatic mutation plays a very important role. However, any new type has to be carefully evaluated before determining if it is a bud mutation or a chance seedling. There is no survey of somatic mutations in root and tuber crops to determine mutation rates. In primitive populations of sweet potato, changes in the skin colour of the root — from white or cream to orange or purple — have been recorded roughly at 1:1000 (Yen 1974). In more reduced samples of improved clones, mutation rates vary from 0 to 2.9% (Hernandez et al. 1964). The frequency of mutation may give an indication of the age of the crop, although it is mainly determined by the number of individuals. Because mutations change only certain characters, the original population could be recognized. The mutants form “groups of varieties” (e.g. in taro and other tuber crops). Within a mutant population not all the individuals are alike (e.g. potatoes). Some may produce subclones that differ in important characters such as yield and resistance to disease.

The same mutation may appear in different places, and this is one of the reasons for the high number of repetitions in collections. However, two mutations phenotypically alike may be different in their physiological responses. Most mutations do not have any agricultural value and in an advanced system of agriculture, where uniformity is highly desirable, they are immediately eliminated. But in primitive systems of agriculture, farmers like to maintain as many types as possible, as a kind of agricultural asset. It is likely that the “magic gardens” of the taro growers of Polynesia are collections of aberrant clones. A similar situation occurs in the mixed agricultural system in the Andes. Primitive farmers have learned by experience that some of these new types may show special resistance and become an important resource when the common clones are wiped out by disease and pests.

Somatic mutations affecting the whole plant are known in few cases. Brachytic types are found in cassava and sweet potato and the main difference between wild and cultivated *Ullucus* is internode length.

Several instances are known in sweet potato in which a normal branch produces others with leaves of different shape (Yen 1974). Characters like the “piko” in taro (a deep cut

of the leaf up to insertion of the petiole, often blotched), or the branching in the corms of *Xanthosoma* and *Colocasia*, could also be attributed to somatic mutations. Colour changes due to mutation were mentioned above in roots of the sweet potato and a characteristic feature of somatic mutation, sector colouring, is found in the petioles of many taro and *Alocasia* clones. Quite common are chimeras affecting colour or structure of the outer layers in tubers and corms. In potatoes and *Ullucus*, buds coming out of areas of different colour give rise to different clones. In potatoes, it is common to find purple areas in white tubers. In *Ullucus*, there is a group of clones with tubers either completely yellow or magenta or with large areas of both colours. In this crop, as in potatoes, russetting is common and types with this kind of skin are recognized as different clones. It is very likely that the ornamental cassava has a similar origin. As mutation rate is a function of population size, it is quite likely that in the relict crops so common among root and tubers, this force is decreasing its effects and therefore reducing crop diversity.

Somatic mutation is probably the most important factor in the evolution of root and tuber crops under cultivation. It is probably easier to find a bud mutation than a chance seedling. However, gene and chromosome mutation, although less well-documented and with far less chances of occurring, may have contributed considerably to the diversity of these crops, especially when they were grown under more natural conditions and seed setting was more frequent.

## Domestication

The process of domestication in root and tuber crops, including potatoes, has not been widely studied. Domestication of grain crops in arid lands has been studied, but the results are of little value in explaining root and tuber domestication. The archeological evidence has considerable limitations. Evidence depends on preserved plant materials, from which we can determine the structure of the organs and environmental conditions. However, because of the fleshy tissues of roots and tubers, they are easily destroyed by fungi, bacteria, and insects. As well, most grow in wet regions and the materials preserved are very scarce and irregularly distributed. The presence of plant remains in dry areas, like the coast of Peru,

provides secondary clues often of great importance, as in the case of the sweet potato, but not the fundamental information on original places and processes. Even less helpful is the indirect evidence derived from tools and pottery. Historical evidence is most important but, like archeology, it provides an irregular picture. Africa has been the foremost meeting place of root and tubers, however its early written history is very fragmentary. A similar situation occurs in southeast Asia and tropical America.

Plant domestication was initiated to answer the needs of primitive man for food, clothing, body painting, medicines, and poisons. It could have been carried out in areas where materials for domestication were abundant but also under the pressure of scarcity (Harlan and Zohary 1966). The common concept that plant domestication led to the establishment of sedentary human communities is open to some questioning. Burkill (1960) suggested that fishing people, who were rather sedentary, after a period of gathering may have started domestication and cultivation of yams. However it may have been a different process for each species, and it is extremely important not to generalize.

Some domestication characteristics common in root and tuber crops are: (1) large size of edible parts; (2) earliness; (3) low content of poisonous or acrid substances; (4) attractive shape and colour; (5) shallow underground growth; (6) sugar content. Other characteristics, such as resistance to disease, may come in more advanced stages of agriculture. The size of the useful parts, like the corms of aroids, and the shape and colour (e.g. Andean tubers) may have attracted the attention of gatherers. In the transition from gathering to cultivation, the main obstacle was the presence of bitter or poisonous substances in the edible parts. The discovery of techniques to eliminate these substances played a decisive role in domestication. The processes differed according to species. One special technique was washing the roots or tubers for many hours to remove poisonous principles. In the Andes this method permitted the use of bitter types of potatoes, mashuas (*Tropeolum*), and oca (*Oxalis*). This also led to the preparation of "chufño," a dry mass easier to store and transport than the whole tubers. Roasting or washing methods were developed in Polynesia to remove the acrid substances from the stems of aroids. The

Polynesians also learned to prepare a taro mash ("poi"), which was more nutritious and easier to keep than the fresh product. The extraction of glucosides in cassava required the development of special techniques and tools.

The planting and cultivation practices and tools are less complicated than those used in preparing the crop for meals. The digging stick of the yam gatherers can be easily transformed into a planting tool. In Hawaii a very simple instrument was developed to cut the upper part of the taro to obtain propagation material (Buck 1964). Evidently early man learned simple cultural practices, such as providing support for yams and piling earth on the base of the plants to supply better and looser soil to the growing tubers. The processes of domestication of roots and tubers, particularly the development of practices and instruments for their preparation as food, were far more difficult than for fruits or grains. Also in selecting less poisonous or acrid clones and developing cultural practices, primitive man showed such ingenuity that Burkill (1951) said they must have "already graduated in horticulture." Out of simple management practices, man evolved more complex systems of agriculture. In southeast Asia, terracing was developed for taro cultivation, which eventually was adapted for rice production. In the Andes, the most complex system was developed to cultivate tubers and other crops, including terracing, fertilization, irrigation, and food storage. This development was far superior to any agricultural system in western Europe or elsewhere in the world in the fifteenth century.

### Geographical Origin and Early Dispersal

Root and tuber crops were domesticated independently in three regions: (1) southeast Asia and its geographic continuation — the Sunda Islands, Papua New Guinea, Oceania; (2) Africa — Madagascar; (3) Tropical America. A few species were domesticated in southern China and Japan. The three regions were active centres of domestication of animals as well. Agricultural systems were developed independently but they have many common features because of similar environments. Prior to the 1500s there were no exchanges of materials and techniques between the Old and the New Worlds. The sweet potato was the only known root crop in tropical America and Oceania.

## Southeast Asia

The Indo-Malayan region, the land between the Deccan peninsula and the South China Sea, could be considered as a primary agricultural hearth because of its domestication of plants and animals, the development of systems of agriculture typical to the region, and the invention or changes in the utilization of plant materials for food and other uses. The region is limited by natural barriers to the north (the Himalayas but in its northeast corner is open towards China) and to the west (the Indian Desert). The rest of the region is surrounded by water. The larger Sunda Islands and Papua New Guinea could be considered as a natural continuation of the region. The Indian section comprises mainly the coastal areas of the Deccan peninsula. In Indochina, the relief is quite complex, and is determined mainly by three major mountain ranges, which run from northwest to southeast with narrow valleys and alluvial plains in between. Its western side, towards the Bay of Bengal, from the foot of the Himalayas to the tip of Malaysia and farther on to Sumatra, Java, and Borneo, is a "tropical rainy" area (over 2000 mm per year). Towards the centre, there are large areas with "tropical rainy" or "wet and dry" climates with savannas and open forests. The vegetation is one of the richest in the world and decreases in number of species from west to east. The conditions in the region are not favourable for the preservation of plant remains, and archaeological surveys have been sporadic.

There were five racial groups in this region belonging to the Negrito stock who, up to this century, lived only by gathering roots and tubers. These were the Andamanese in the Andaman Islands; the Semang in North Malaya; the Kadar and the Chenchu in the Western Ghats in India, and the Veddas in Sri Lanka (Burkill 1953; Coon 1974).

The gathering practices of these groups give a picture of how man lived before agriculture. Even today, small groups of food gatherers in this region collect yams and aroids which are abundant in the rain forest. Because of their reduced numbers and the availability of other food sources, they have survived in the same areas for many centuries.

The Negrito stock settled in the region some 25 000 years ago, but was pushed eastwards by other immigrants and is represented today only by enclaves. The new arrivals, Australoid and

Mongoloid, came in successive waves from different regions. They mixed together and the resulting population, to which the names of Indo-Malays or Malays have been applied, was possibly the group that started plant domestication. Burkill (1953) says it is likely that root and tubers were the first domesticated crops in this area.

As was stated earlier, the development of more efficient techniques in food preparation may have been as important in domestication as the development of crop husbandry. Yams gathered in India and Malaya are roasted or cooked. The removal of poisonous substances or acrid materials in yams and aroids is done by pounding, washing, and heating. Thus, through a combination of simple practices and tools, it was possible in this region to start an agricultural system based on the production of tuber crops. The region is extremely rich in other foods, especially fruits — mangoes, durian, rambutan and others — which grow wild in the forests. Fish and wild animals supplied the necessary protein. The later domestication of rice in the region started a new pattern of agriculture.

The most important expansion of root and tuber crops from the Southeast Asian region was eastward, carried out by a mixed group, the proto-Malays, which moved from the continent first to the Great Sunda Islands and then to Papua New Guinea, about 3000 years ago. The first expansion occurred about 2000 years ago with the settlement of Polynesia when the Malays from Samoa and Tonga reached the Marquesas to the east, Tokelau to the north, and the Ellice islands to the northeast. Previously, Micronesia had been settled by other immigrants from the Sunda and Philippine islands. The second expansion occurred before 500 AD when the Polynesians starting from the Marquesas reached the extremes of the Polynesian triangle (i.e. Hawaii, Easter Island, New Zealand). There are no written records before 1500, and linguistic and archaeological evidence is not strong enough to support the view that in Oceania there was a pre- and post-Polynesian stage in agriculture.

Towards the west, the expansion of crops was prevented by the dry and desert areas in northeast India. Only one species (*Colocasia esculenta*) may have followed a land route, either through Syria or by the Sabeen Lane to Egypt.

To the northeast, taro and some yams

moved into the subtropical areas of China and from there to Japan.

From the background of roots and tubers, new crops and techniques were developed in Southeast Asia and Malaysia, thus creating a large agricultural complex. Rice was the main crop on the continent and the large islands, alone with bananas, sugar cane, breadfruits and many other minor crops. The oldest archeological date for rice in India is 4300 BC. By that time other cereals such as wheat and sorghum had been introduced and were already in cultivation (Rao 1974).

### Aroids

*Alocasia macrorrhiza* (*A. indica*). This is a very primitive crop, possibly domesticated in India (Assam, Bengal), or in Indochina; in India other species (e.g. *A. cucullata*) are cultivated and wild *Alocasia* is used as food. Its large trunk contains a fine starch, but because of the high oxalate content, it must be cut and baked on hot stones, or boiled. In Java and Tonga some cultivars are used only for their leaves. *Alocasia* spread only to the east towards Melanesia and Polynesia. It is of some importance in Tonga and Samoa and to all of Micronesia, especially the Marshall Islands, and was introduced into Brazil in the last century as cattle feed.

*Amorphophallus campanulatus*. This plant is found from India to Polynesia but with no clues as to the area of domestication. It is an ancient plant, low-yielding, and difficult to prepare for eating, with the result that it is being grown less and less. It is cultivated from India to Malaysia, and in Java as a backyard crop (Sastrapradja 1970). In Polynesia, it grows wild and is occasionally gathered, but is unknown in Micronesia (Barrau 1962).

*Colocasia esculenta*. This species is found wild from India to Southeast Asia, and has spread throughout the tropical world and to the fringes of the temperate regions.

Towards the east, the plant was spread by the Malaysians and Polynesians to all the islands of Oceania, including Hawaii, Easter Island, and New Zealand. In this vast area, some hundreds of clones are known, but there is no complete survey of its diversity. From chromosome counts, it has been established that there are two types,  $2n = 28$  and  $2n = 42$ , with the former the predominant type from India to Japan and Polynesia. Type  $2n = 42$  occurs in India, New Zealand, and the Philippines and

seems to have originated in India. It has spread eastward in recent times, but is not found in Polynesia (Yen and Wheeler 1968).

It reached China and the Lower Yangtze valley and is mentioned in literature towards 100 BC. From China it moved into Japan. The introduction into the Philippines came possibly through the Sunda Islands.

The spread of *C. esculenta* to the west is poorly documented. It reached Egypt around 100 AD, either through Syria (and there is some linguistic support for this, Tackholm and Dar 1950), or through the Sabeen Lane, since it is found in Yemen from where it may have originated. From Egypt, it went through North Africa to Morocco and then to Spain and Portugal. It spread also from Egypt to Italy and to Cyprus, where it is an old and important crop.

When, where and by whom Southeast Asian crops were transported to Africa is still open to question. Indians or Indonesians settled south of Ethiopia around 500 AD, leaving instruments and practices, like certain types of boats along the coast of Zanj and the lakes, and they brought in their crop plants from Malaysia. Madagascar is culturally linked with Indonesia, and many of the words for crops like *Tacca*, coconut, taro, are the same in the two areas. The Malay sailors may have reached the coast of Africa with the favourable winds during the monsoon season. Propagation material of roots and tuber crops, brought in these trips, may have remained viable for weeks and very likely were established in Africa after many failures. Taro, bananas, greater and lesser yams, and sugar cane were adopted by the Bantu people and other tribes on the continent. Either by the geographic spread of the former ethnic group, or through diffusion into different tribes, these crops reached central Africa and later on west Africa. Taro was already in cultivation in Gambia and San Thomé around 1500 (Mauny 1953).

Taro was taken from west Africa to tropical America, probably in the early 1500s. However, it is difficult to establish its arrival because early descriptions confuse it with *Xanthosoma*. By the end of the 18th century it had spread from the Caribbean to Brazil, and early in this century to the southern coast of the United States. Again, very little is known of its diversity in this area. Superior clones, called "dasheen," are recent introductions but the native *Xanthosoma*, being more productive

and resistant, has prevented the expansion of *Colocasia esculenta* in the American tropics.

*Cyrtosperma chamissonis*. This aroid was not domesticated on the continent since it is not cultivated in India and Malaysia. Its range extends from Indonesia to the north side of New Guinea; in Melanesia, the Solomons and Fiji, but not in New Caledonia; in Polynesia, in the central part as far as the Marquesas, but not in Hawaii or Southeast Polynesia; throughout Micronesia, as it grows well in the low atolls (Barrau 1962).

### Yams (*Dioscorea*)

Six species of *Dioscorea* were domesticated in this region: *D. alata*, the "greater yam," originated in the area occupied by Burma and China where the rivers Irrawaddy, Salween, and Mekong ran closely and parallel to each other (Burkill 1951). This is a mountainous area with alternate seasons. Two wild species, closely allied to *D. alata*, and many primitive cultivars are found here. These yams grow large rhizomes deep in the soil to survive the dry season, and this characteristic may have attracted the attention of man since early times.

The greater yam was taken first to the Sunda Islands, to the east, quite possibly only as clones with shallow-growing tubers. Many mutants were concentrated or appeared in these islands, differing in tuber shape and size, and in other characteristics, and this area has the highest diversity of the species. It spread also to the Philippines and to all parts of Oceania, including New Zealand. Toward the west, it extended to west India, stopped by the Great Indian Desert. It spread toward Africa, maybe taking the same route as taro, banana, and other Southeast Asian crops. It spread to East Africa and Madagascar, and later to central and west Africa. In the latter region, however, it did not become important because there were already native yams under cultivation. An historical expansion took place after 1500, when the Portuguese brought it to the west coast of Africa. It became the main food in the slave ships and was marketed widely as "Lisbon yams," especially from San Thomé. With the slaves, the greater yam arrived quite early, around 1530, in the Caribbean and Brazil, but in the New World its expansion was checked again by the African yams.

*Dioscorea esculenta*, the "lesser yam," was possibly domesticated in the same area as *D. alata*. Wild types have been reported from

India and Guam. Before the arrival of the Europeans, it had spread from Southeast Asia to the Philippines and into Oceania but not beyond Tahiti, and north to China, where it is mentioned in the literature around 200 and 300 AD. It was taken by the Portuguese, along with *D. alata*, around the Cape to west Africa. By selection, superior clones with larger and fewer tubers and less thorny stems have been obtained in Southeast Asia and Oceania. Recent collections suggest that this species has a greater potential than previously realized (Martin 1974b).

*Dioscorea bulbifera* was independently domesticated in the region, and the Asiatic clones show morphological and cytological differences from the African cultivars. It is found from India to north Australia (only wild types on this continent) and all over Oceania. Asiatic clones have recently been introduced to tropical America (Martin 1974a).

*Dioscorea hispida* extends from west India, where it is sporadically cultivated, to Malaysia and Papua New Guinea. In Java it is planted as a minor crop. The cultivated types are often as poisonous as the wild plants.

*Dioscorea nummularia* is a relict crop, found from the Philippines to Borneo, Celebes and Papua New Guinea and Tahiti, but is not cultivated in Java, Sumatra, or New Caledonia.

*Dioscorea pentaphylla* grows wild in India, southern China (to 22°N), Philippines, Indonesia, and all over Oceania; cultivated types have been selected in separate localities in Malaysia and Oceania.

### Other minor root and tuber crops originating in this region

*Cordyline terminalis* is found wild in Southeast Asia, Australia, and most of Oceania; a clone with green foliage extensively planted for the fleshy roots that contain levulose (Ezumah 1970). *Curcuma augustifolia* is planted in south India as a source of starch, "East Indian arrowroot," and *C. zedoaria*, used for the same purpose, is cultivated mainly in north India and Sri Lanka (Kundu 1967). *Tacca leontopetaloides* is planted sporadically from Southeast Asia, Philippines to eastern Polynesia as a source of starch, the "Tahiti arrowroot." It was possibly domesticated by Polynesians, who developed several ways of preparing it for food or starch, but it is now losing importance. It was taken by Malays to

Madagascar but it is likely that the African cultivars found from west Africa to Ethiopia may have an independent domestication. It has not improved as has the Malaysian crop. *Pueraria thunbergiana* (*P. lobata*) is cultivated in the highlands of Papua New Guinea for its fleshy roots. *Psophocarpus tetragonalobus* is cultivated from India to Polynesia, especially in Burma, for the fleshy, sweetish roots. Its origin is unknown, though it could be traced to Africa. The recent interest in this crop is due to the protein value of the seeds. It is widely planted as a vegetable for its green pods.

### Root and tuber crops in the Far East

Several species have been domesticated in China or Japan but they have not spread much outside this region. In the last decades in China, both native and introduced root and tuber crops have had a large expansion in area and production. These far eastern species include: *Dioscorea opposita*, the "China yam," is possibly derived from *D. japonica*; *Amorphophallus rivieri*, or "bonjac," is found in Japan, China, and possibly Vietnam. Its origin is possibly south China, with quite a complex utilization in Japan; *Eleocharis dulcis*, the "water chestnut," is assumed to be the cultivated form of *E. tuberosa*, a wild species widely distributed in the Asiatic tropics; *Sagittaria sagittifolia* is cultivated mainly in China for its tubers, and was introduced by the Chinese to Polynesia and *Stachys sieboldii*, which is referred to in the Chinese literature of the fourteenth century, is also grown in Japan. It was introduced into Europe at the end of the nineteenth century and became quite popular in France.

### Africa

In Africa, more than in any other continent, we see a full range in the gradual transition in utilization of root and tuber crops, from gathering of wild materials to well-established cropping systems. The African root and tuber crops were domesticated south of the Sahara, some in the savanna region, others in the Guinean forest. Africa is also the meeting point for Asian and American roots and tubers, and nowhere else has there been such drastic replacements in these crops. Among the Asian roots and tubers, taro (*Colocasia esculenta*) was the first.

Several African crops were taken to Asia by

the Malays or Indians. Among the root and tubers, *Plectranthus tuberosus* was introduced to India and Indonesia. Perhaps the two cultivated species of *Psophocarpus*, if they are African, followed the same route.

From tropical America the introductions are more recent and important: cassava, sweet potato *Xanthosoma*, and potatoes have drastically changed the agricultural systems and food habits in west and east Africa. The Guinean yams were taken very early to the Antilles and the coast of Brazil, during the slave trade, and are now the most important yams in the region.

### Yams

The main contribution of Africa in root and tuber crops is the domestication of the Guinean yams *Dioscorea cayenensis* and *D. rotundata*. These have been considered one species with *D. rotundata* as a subspecies of *D. cayenensis*, but the recent trend is to keep them apart, partially based on anatomical characters (Coursey 1967). The Guinean yams are especially important in West Africa, and were probably domesticated in this area 5000 BP. (Coursey 1976; Ayensu and Coursey 1972).

*Dioscorea cayenensis*, the "yellow yam," which is less important than the white yam, is a polyploid of unknown origin, although it may derive from *D. minutiflora* or other closely related species. It grows wild throughout West Africa, and was probably domesticated in the Guinea coastal area, spreading through the Guinean region in areas of high rainfall. Thornless clones have been introduced into tropical America.

*Dioscorea rotundata*, the "white yam," is supposed to be a hybrid between *D. cayenensis* and *D. praehensilis* (Ayensu and Coursey 1972). It is more widely adapted to moisture conditions, and its cultivation is most intense in Nigeria. It has spread from Senegal to south Ethiopia, including parts of the savanna area, and to Uganda, Angola, and Northern Rhodesia. It is also cultivated in the Comores and Madagascar. The primitive types have thorny roots which provide good protection, but through selection of mutants, thornless clones have been established and were taken to tropical America during the slave trade where it has become the most important yam.

The following yams are of lesser importance. *Dioscorea bulbifera*, which was mentioned before, is found in Southeast Asia and Polynesia.

There are differences between the Asian and the African clones, the latter being less advanced in their domestication. Some clones do not produce underground tubers. It grows roughly between 10°N and to 10°S lat throughout west Africa and from the Nile valley near the Ethiopian border to Southern Rhodesia. The clones in tropical America seem to belong to the African group. *Dioscorea dumetorum* is cultivated particularly in the border of the yellow yam plots, and is found wild through Africa from 15°N to 15°S (Ayensu and Coursey 1972). Other species cultivated are *D. abyssinica*, *D. colocasiifolia*, *D. hirtiflora*, *D. praeheensis*, *D. quartiniiana*, and *D. sibirica*. In Madagascar a number of local species (*D. antaly*, *D. ovinata*, *D. soso*, the latter with very sweet tubers) have been domesticated but their cultivation is being reduced by cassava and sweet potato.

### The African tuberous Labiatae

In the mint family (Labiatae) the formation of tubers is not uncommon, as was mentioned under *Stachys sieboldii*. Two African species have been domesticated. One was taken some centuries ago to India and Indonesia, and has become a regular crop in these countries (Chevalier 1905).

*Plectranthus esculentus* (*Coleus dazo*, *C. esculentus*, *C. langouassiensis*, *C. floribundus*), the "Kafir potato" is native to west and central Africa, though its origin and variability are unknown. The plant produces many elongated tubers, arising from the central stem.

*Solenostemon rotundifolius* (*Coleus dysintericus*, *C. rotundifolius*, *C. coppini*, *Plectranthus tuberosus*, *P. ternatus*), the "Hausa potato" is cultivated in west and central Africa to Transvaal and Madagascar. The plant produces spheric to ovoid tubers, dark red and white. It is an old introduction to India ("koorkan"), Malaysia, Indonesia, and recently to the Philippines.

### Tuberous Leguminosae

Two species of possible African origin, *Psophocarpus palustris* and *P. tetragonolobus*, are cultivated widely in tropical Africa and Asia for their fleshy, sweet roots and for the green pods. The second species, by far the most important, is intensively cultivated in Burma for its tuberous roots. The origin of these species is unknown. *Psophocarpus* is

found from tropical Africa to Papua New Guinea.

*Sphenostylis stenocarpa*, one of the "yam beans," of African origin possibly from Ethiopia, is cultivated in east Africa and the Guinea area for its spindle-shaped tubers and dry seeds.

### *Tacca leontopetaloides*

#### (*T. involucrata*, *T. pinnatifida*)

This species is found wild from Senegal to East Africa and also in Southeast Asia and Oceania. In Africa it is seldom cultivated. The tubers require careful preparation to remove the toxic principles; in some places they are used as a source of starch.

### Tropical America

The three most important root and tuber crops — potatoes, cassava, sweet potato — come from Tropical America. Other crops, like *Xanthosoma*, are of high potential value and several minor crops offer limited possibilities due to their physiological requirements.

The American root and tuber crops have two main areas of domestication — the high Andes and the lowlands in northern South America, and a secondary area, Middle America. The Andean crops include potatoes, oca (*Oxalis tuberosa*), mashua (*Tropaeolum tuberosum*), ulluco (*Ullucus tuberosum*), and maca (*Lepidium meyeri*) that were domesticated in the Peruvian-Bolivian altiplano, above 300 m, and two crops native to the northern section of the Andes (i.e. Colombia), at lower elevations (1000–2500 m), arracacha (*Arracacia xanthorrhiza*) and yacon (*Polymnia sonchifolia*). In the Andes, other root and tuber crops were early introduced from lower areas and became an important part of the agricultural complex: sweet potato, achira (*Canna edulis*), ahipa (*Pachyrrhizus* sp.).

The second source of root and tuber crops is the lowlands of northern South America including the Antilles, an area of very imprecise limits, in which *Xanthosoma* spp., arrowroot (*Maranta arundinacea*), lairen (*Calathea allouia*), *Pachyrrhizus tuberosus*, and possibly cassava and sweet potato were domesticated. Middle America, which is so rich in native crops, has contributed few and unimportant crops: jicama (*Pachyrrhizus erosus*) is the most outstanding and has spread to Asia and Oceania. In pre-Colombian times and even to-

day in remote localities, some plants are gathered for their tubers or corms: *Bomarea edulis*, *Dalechampia* spp., some beans (*Phaseolus*), *Tigridia pavonia*, and *Dahlia* spp. The last two species are now grown as ornamentals but were once used for their corms and fleshy roots respectively. *Sechium edule* is planted for its fruit though it also yields edible roots. The early introduction of cassava and sweet potato to Middle America probably prevented the domestication and expansion of the local tuber crops.

### Cassava

Cassava (*Manihot esculenta*), known only under cultivation, is a complex of clones showing the widest morphological diversity in the Paraguay–South Brazil area. Clusters of closely-related species to cassava are located in both North and South America (Rogers and Fleming 1973), but no wild species have been suggested as a possible ancestor. The time and place of domestication are unknown. The most important trait for the use of cassava as a food is the HCN content in the roots, which has a wide range from high (bitter cassavas) to very low (sweet cassavas). There is a clear correlation in the geographic distribution of the two kinds: sweet cassavas occur in the western side of South America, Central America–Mexico, while bitter clones are planted mainly in the eastern side of South America and the Antilles, with an overlapping area in between (Renvoize 1972). Archeological evidence is very scarce. The remains of cassava leaves have been identified in caves in Mexico dated 2500 BP, and tubers in coastal Peru from about the same age. Indirect evidence, such as the presence in early times of grinding stones in Colombia and Venezuela assumed to be used for grinding cassava roots, is not very convincing. It is also assumed that cassava flour was an important article of commerce in northern South America in the second and third millennia BC (Jennings 1976). What is clear is that cassava was more intensively used in South America than in Middle America. In the former area, the artefacts for the preparation of flour were far more developed, and other uses, such as the utilization of leaves as vegetables or for the preparation of sauces, are typical of South America. Archeological information, such as representations in ceramics and early historical information, gives additional support to a more intensive use in South America. Its role in the

Mayan agriculture is still open to discussion (Bronson 1966; Cowgill 1971), but it is unlikely that cassava could have been a very important food source in the conditions of Yucatan and Petén. All this may point to a South American domestication and the fact that its spread towards the north was restricted to the sweet varieties. On the other hand, Humboldt suggested that the sweet types may have been domesticated first and that later on man learned how to utilize the bitter varieties.

Cassava was introduced early to Africa by the Portuguese. The first published report by Barré and Thevet is dated 1558 (Mauny 1953). Further spread inside Africa was determined by its adoption first as a vegetable and later as a flour source in the Kingdom of Congo, which was an advanced state that influenced the rest of tropical Africa. The spread apparently was rather slow, but was favoured by the resistance of cassava to locusts (Jones 1959).

Cassava was introduced to India and South-east Asia late in the nineteenth century.

### Sweet potato

Sweet potato (*Ipomoea batatas*) was the only food crop common to Tropical America and Polynesia before the Discovery. As such, it has raised a long discussion on which of the two regions is its place of origin and on how its early dispersal occurred (Yen 1974). The recent discovery in coastal Peru of sweet potato tubers dating from 10 000 BP (Engel 1970) settles the question of the origin, as this date by far antedates any agricultural development in Polynesia. However, it should be considered that, like all other plants cultivated in the coastal region of Peru, sweet potato was introduced from elsewhere, possibly from the north, the coastal area of Ecuador and Colombia, where close wild types have been found (Martin et al. 1974), or from across the Andes, like *Canna edulis* and other crops.

At the arrival of the Europeans, the sweet potato was known in all Tropical America, with an important area of diversity around the Caribbean. Oviedo, writing in 1530, reports that several varieties he had seen in the early days of the Conquest were already disappearing.

The spread of the sweet potato to the Old World was quite rapid; it was introduced in Spain, after several failures, as living plants before 1550. It is not known how it reached Africa, whether from Spain or from tropical

America. A report that sweet potato was grown in San Thomé in 1520 seems doubtful (Mauny 1953). More reliable information shows that it was widely cultivated by the end of the seventeenth century in West Africa, and a century later all over the tropical areas of the continent.

The introduction to Polynesia, as discussed above, has not been properly explained. It could have been accidentally transported in one of the Peruvian rafts lost in the Central Pacific, which reached Polynesia where the crop was established by Indo-Americans and developed later on by Polynesians. It has been proposed also that the sweet potato may have been taken to Polynesia by one of the Spanish expeditions that visited the area starting from Peru in the sixteenth century. It was taken to China in 1594 and after a famine in Fukien, it later became an important crop. Sweet potato was introduced early to Japan from Okinawa and cultivated and adopted in the southern region up to 35°N.

### Xanthosoma

The identification of the species of *Xanthosoma*, cultivated for the corms, is still not clear. The "species" described vary between themselves like the clones of taro which is now considered to be one species. The genus is found from Mexico to Brazil, but the cultivated "species" are centred around the Caribbean. There is no information on the evolution of this crop. It is superior to taro in yield, resistance to disease, adaptability, and taste, and therefore it is not surprising that this species is replacing taro all over the tropics. *Xanthosoma* was introduced to Africa by the middle of the last century, where the replacement is most active.

### Tubers of the high Andes

A group of tuber crops was domesticated in the high Andes, above 3000 m, where they are now intensely cultivated (Léon 1964). The most important are the potatoes, which at present are considered as one species, *Solanum tuberosum*, including: (i) two tetraploid groups, *Tuberosum* and *Andigena*; (ii) a triploid, *Chaucha*; (iii) two diploids, *Phureja* and *Stenotomum*; (iv) two interspecific hybrids,  $\times$  *juzepozukii*, triploid, a cross between *S. tuberosum*  $\times$  *S. acaule*, and  $\times$  *curtilobum*, resulting from *S. tuberosum*  $\times$  *juzepozukii* (Ugent 1970).

In spite of its importance, very little is known on the domestication and early dispersal of the cultivated potato, but the complexity of its structure as a species shows that it has a long history. The oldest tubers are dated 200 BP (Ochoa, personal communication) and potatoes are represented in ceramics of the third century BC. Although very little is known of the domestication process, the early spread to Europe and other continents is fairly well documented (Dodds 1966; Hawkes 1967).

Other root and tuber crops of the highlands are: *Oxalis tuberosa*, or "Oca", of which no wild ancestors are known. It has a large number of clones differing in size, colour, and shape of the tuber, plant size, foliage colour, and heterostyly. Clones with bitter tubers are used to prepare "chuño." The oca was introduced into Mexico during colonial times ("papa extranjera"), into southern France, and last century to New Zealand where it is called "yam." *Ullucus tuberosus* has slimy tubers which are not as attractive as ocas, but they are consumed even in the large towns. Wild or ancestor types grow in the highlands of Peru and Bolivia. Two main groups of clones are known: in the northern extreme of the range (Colombia), with trailing branches and large, red tubers; and in Peru and Bolivia, erect, short branches, with multi-coloured tubers. The ulluco was introduced into southern Europe but it is not planted. *Tropaeolum tuberosum* grows in the same area as oca. No wild relatives are known, although some other South American species are reported to form large tubers. Two main groups of clones are known: in Colombia, tubers are slim, white, with deep eyes from which emerge fine rootlets; and in Peru and Bolivia, the tubers do not have rootlets and the predominant colours are yellow with purple lines or fine points. The mashua grows often at altitudes where only bitter potatoes are produced. *Lepidium meyeri* produces a radish-like root, sweet, yellow or dark purple in the highlands of Peru, above 400 m. It is a relict crop that is rapidly disappearing.

### Other Andean root and tuber crops

At lower elevations in the Andes, between 0 and 3000 m, several root and tuber crops are grown: *Arracacia xanthorrhiza*. "Arracacha" is especially important in Venezuela and Colombia; no wild types are known and it seems to be of ancient cultivation. Several clones are known to differ in shape and size of

the roots, foliage, colour, etc. It has been introduced into Middle America, Brazil, East Africa, India; *Canna edulis* is possibly native to the eastern part of the Andes, and was brought to the coast of Peru where it has been cultivated since 4000 BP; diploid and triploid types are known (Mukherjee and Khoshoo 1971); cultivated in Australia ("Queensland arrowroot"), Hawaii, India, Polynesia; *Polytmnia sonchifolia* is cultivated from Venezuela to Argentina, and according to Bukasov (1930) grows wild in Colombia. The tuberous roots are fleshy, contain sugar (10%), and were used in colonial times on long sea trips; introduced to southern Europe as a forage crop; *Pachyrrhizus* sp. are ancient crops in the Andes, probably introduced from the Amazonian lowlands.

### Minor tropical American root and tuber crops

The West Indian yam (*Dioscorea trifida*) is the only species of the genus domesticated in the American tropics, although other species are gathered, particularly in Brazil. The species has the highest diversity in the area between the Guianas and Brazil and selected types are planted in the Antilles. Its domestication was, of course, independent of the Asiatic and African yams (Alexander and Coursey 1969).

Arrowroot (*Maranta arundinacea*) was, around the middle of the eighteenth century, used mainly to cure the wounds from poisoned arrows, and also started to be used in the Antilles as a source of starch (the "St. Vincent arrowroot" — Stutervant 1969).

Lairen (*Calathea allouia*) was intensively cultivated at the time of the Discovery in the Great Antilles and the Continent. The ovoid tubers are now used for food mainly in Venezuela.

Several species of jícamas (*Pachyrrhizus* spp.) are cultivated in South America, and are particularly important in Mexico and Central America. From Mexico the plants went, by the Acapulco–Manila connection, to the Philippines and subsequently spread to Southeast Asia and Oceania. Plants of the same "species" offer such a variability in size, shape of leaves, and tuberous roots that the specific limits are difficult to recognize.

### Conclusion

In considering the evolution of root and

tuber crops, the roles of polyploidy, mutation, and vegetative propagation give some clues to the general process. Some outstanding research in sweet potatoes has established the possible transition stage of the wild diploids to a complex hexaploid, and has recognized wild populations which may have had a role in the development of the crop. But in sweet potato, and even in the common potato, there is an appalling ignorance as to how domestication traits occurred. Today there are increasing doubts among anthropologists and botanists about the capacity of primitive man to have carried out crop selection. Primitive farmers profited from the presence of edible organs in certain species. However, it is quite difficult to explain how he could carry on the improvement of inherent traits without knowledge of the rules of genetics and the help of permanent records. On the other hand, primitive man exchanged planting materials with his neighbours, and in vegetative crops he introduced superior clones and thus eventually contributed to their hybridization. At the same time, by moving crops to new areas, he restricted the possibilities of further crossing with the species of its native habitat. Man-made isolation has been, therefore, an important factor in the evolution of crop species. Man has also executed an important action in taking plants to new habitats. This is seen more clearly in relation to the selective impact of diseases and pests, such as the attack of cassava viruses in Africa.

Roots and tubers are ancient crops and primitive man independently domesticated species of the same genus (*Dioscorea*) or of allied species (*Colocasia* and *Xanthosoma*, *Pachyrrhizus* and *Pueraria*) in different parts of the world and at different times. Many of these crops, due to physiological constraints or lack of acceptability, have not spread farther than their native habitat, and in fact many are now becoming relicts in old agricultural systems. Their spread, particularly after the Discovery, has led to competition among themselves and to the eventual replacement of some species, a process that continues today.

Root and tuber crops are associated with primitive systems of agriculture. A duality has been established between seed agriculture, which is supposed to be a dynamic process characteristic of advanced communities, and vegetative propagation which is supposedly maintained by more primitive communities. The fact is that in the tropics there is no such

difference, and root and tuber crops as the only source of energy food are found only in a few isolated communities. Grains and tubers are integral parts of most agricultural systems in which they have different not antagonistic roles. Perhaps the best answer to the academic problem of seed versus vegetative culture lies in the ceramics of the Trujillo valley in Northern Peru. On one of these ceramics dating from around 1500 BP an Indian farmer is shown holding, at the same level, a corn plant in one hand and a cassava plant in the other.

Abraham, A., Panicker, P. K. S., and Mathew, P. M. *Polyploidy in relation to breeding in tuber crops*. J. Ind. Bot. Soc. 43, 1964, 278-282.

Alandia, S. *Producción de semilla sexual en oca*. Sayaña, 5, 1967, 12-15.

Alexander, J., and Coursey, D. G. *The origins of yam cultivation*. In Ucko, P. J., and Dibley, G. W., eds., *The domestication and exploitation of plants and animals*. 405-425, 1969.

Ayensu, E. S., and Coursey, D. G. *Guinea yams*. Econ. Bot. 26, 1972, 301-318.

Barrau, J. *Les plantes alimentaires de l'Océanie*. Ann. Mus. Com. Marseille Sér. F. 1955-61. 1962.

Bronson, B. *Roots and the subsistence of ancient Mayas*. Southwest. J. Anthr. 22, 1966, 251-279.

Brucher, H. *Ullucus aborigineus, spec. nov. die wildform einer andinen kulturpflanze*. Ber. Deutsch. Bot. Ges. 80, 1967, 376-381.

Buck, P. H. (Te Rangi Hiroa). *Arts and crafts of Hawaii. I. Food*. B. P. Bishop Museum Spec. Publ. 45. Honolulu, 1964.

Bukasov, S. M. *The cultivated plants of Mexico, Guatemala and Colombia*. Bull. Appl. Bot. Gen. Pl. Br. Supl. 47, 1930.

Burkill, I. H. *The rise and decline of the greater yam in the service of man*. Adv. Sci. Lond. 7, 1951, 443-448.

*Habits of man and the origins of the cultivated plants in the Old World*. Proc. Linn. Soc. Lond. 164, 1953, 12-42.

*Organography and evolution of the Dioscoreaceae, the family of yams*. J. Linn. Soc. (Bot.) 56, 1960, 319-412.

Chevalier, A. *Les végétaux utiles de l'Afrique tropicale. I. Coleus*. Depot des Publications, Paris, 1905.

Clark, J. D. *The spread of food production in sub-Saharan Africa*. J. Afric. Hist. 3, 1962, 211-228.

Coon, C. S. *The hunting peoples*. Penguin, London, 1974.

Coursey, D. G. *Yams*. Longman, London, 1967. *Yams, Dioscorea spp. (Dioscoreaceae)*. In Simmonds, N. W., ed., *Evolution of crop plants*. 70-74, 1976.

Cowgill, U. M. *Some comments on Manihot subsistence and the ancient Maya*. Southwest. J. Anthr. 27, 1971, 51-63.

Darlington, C. D. *The evolution of man and society*. Allen and Unwin, London, 1969.

Dodds, S. K. *Classification of cultivated potatoes*. In Correl, D. S., ed., *The potato and its wild relatives*. Renner, Texas, 1962.

*The history and relationships of cultivated potatoes*. In Hutchinson, Sir J., ed., *Essays on crop evolution*. Cambridge, 123-141, 1965.

*La evolución de la patata cultivada*. Endeavour 25, 1966, 83-88.

Engel, F. *Exploration of the Chilca canyon*. Curr. Anthr. 11, 1970, 55-58.

Ezumah, H. *Miscellaneous tuberous crops of Hawaii*. Tropical root and tuber crops tomorrow. 1, 1970, 166-171.

Harlan, J. R., and Zohary, D. *Distribution of wild wheats and barley*. Science, 153, 1966, 1074-1080.

Hawkes, J. G. *The history of the potato*. J. Roy. Hort. Soc. 42, 1967, 207-224; 249-365.

Hernández, T. P. et al. *Frequency of somatic mutations in several sweet potato varieties*. Proc. Amer. Soc. Hort. Sc. 85, 1964, 430-433.

Jennings, D. L. *Variation in pollen and ovule fertility of cassava and the effect of interspecific crossing on fertility*. Euphytica, 12, 1963, 69-76.

*Cassava, Manihot esculenta (Euphorbiaceae)*. In Simmonds, N. W., ed., *Evolution of crop plants*. Longman, London, 81-84, 1976.

Jones, W. O. *Manioc in Africa*. Stanford, Calif., 1959.

Juzepczuk, S. M. *New species of the genus Solanum in the group Tuberarium*. Bull. Acc. Sc. USSR, 2, 1937, 295-331.

Kundu, B. C. *Some edible rhizomatous and tuberous crops of India*. Proc. Intern. Symp. Trop. Root Crops, 1, 1967, 124-130.

Leon, J. *Plantas alimenticias andinas*. IICA Bol. Tec. 6. Lima, 1964.

Magoon, M. L. *Recent trends in cassava breeding in India*. Proc. Intern. Symp. Root Crops. 1, 1967, 100-113.

Magoon, M. L. et al. *Cytomorphological studies on induced polyploids of cassava*. Gen. Iber. 21, 1969, 1-47.

Magoon, M. L., Krishnan, R., and Vijaya, K. *Cytological evidence on the origin of the sweet potato*. Theor. Appl. Gen. 40, 1970, 360-366.

Martin, F. W. *The sterility-incompatibility complex of the sweet potato*. Proc. Intern. Symp. Trop. Root Crops, 1, 1967, 3-15.

*Tropical yams and their potential. Part 1. Dioscorea esculenta*. USDA. Agric. Handb. No. 457, 1974a.

*Tropical yams and their potential. Part 2. Dioscorea bulbifera*. USDA. Agric. Handb. No. 466, 1974b.

- Martin, F. W., Jones, A., and Ruberté, R. M. *A wild Ipomoea species closely related to the sweet potato*. *Ec. Bot.* 28, 1974, 287–292.
- Mauny, R. *Notes historiques autour des principales plantes cultivées d'Afrique occidentale*. *Bull. Inst. Franc. Afrique Noir* 15, 1953, 684–730.
- Mukerjee, I., and Khoshoo, T. N. *Genetic evolutionary studies in starch yielding Canna edulis*. *Gen. Iber.* 23, 1971, 35–42.
- Nishiyama, I. *Evolution and domestication of the sweet potato*. *Bot. Mag. Tokyo*, 84, 1971, 377–387.
- Nishiyama, I., Miyazaki, T., and Sakamoto, S. *Evolutionary autopoloidy in the sweetpotato (Ipomoea batatas (L.) Lam.) and its preogenitors*. *Euphytica* 24, 1975, 197–208.
- Plucknett, D. L. *Edible aroids, Alocasia, Colocasia, Cyrtosperma, Xanthosoma (Araceae)*. In Simmonds, N. W., ed., *Evolution of crop plants*. London, 10–12, 1976.
- Rao, M. V. *Crops of West Asia. Cereals*. In Hutchinson, Sir J., ed., *Evolutionary studies in world crops*. Cambridge, 1974.
- Renvoize, B. S. *The area of origin of Manihot esculenta as a crop plant—a review of the evidence*. *Ec. Bot.* 26, 1972, 352–360.
- Rogers, D. J., and Fleming, H. S. *A monograph of Manihot esculenta with an explanation of the taxometric methods used*. *Ec. Bot.* 27, 1973, 3–113.
- Sadik, S., and Obereke, O. U. *A new approach to improvement of yams, Dioscorea rotundata*. *Nature*, 254, 1975, 134–135.
- Sastrapradja, S. *Inventory, evaluation and maintenance of the genetic stocks at Bogor*. *Trop. Root and Tuber Crops Tomorrow*, 2, 1970, 87–89.
- Sauer, C. O. *Agricultural origins and dispersals*. The American Geogr. Society, New York, 1952.
- Sharma, A. K., and de Deepesh, N. *Polyploidy in Dioscorea*. *Genetica*, 28, 1956, 112–120.
- Simmonds, N. W. *Potatoes, Solanum tuberosum (Solanaceae)*. In Simmonds, N. W., ed., *Evolution of crop plants*. Longmans, London, 279–283, 1976.
- Stutervant, W. C. *History and ethnography of some West Indian starches*. In Ucko, J. J., and Dimsley, G. W., eds., *The domestication of plants and animals*. Duckworth, London, 177–199, 1969.
- Subramanyan, K. N., Kishore, H., and Misra, P. *Hybridization of haploids of potato in the plains of India*. *Curr. Sci.* 41, 1972, 580.
- Tackholm, V., and Dar, M. *Flora of Egypt. Vol. 2*. Cairo, 1950.
- Ugent, D. *The potato*. *Science*, 170, 1970, 1161–1166.
- Yen, D. E. *The sweet potato and Oceania. An essay in ethnobotany*. B. P. Bishop Museum Bull, 236, Honolulu, 1974.
- Yen, D. E., and Wheeler, J. M., *The introduction of taro into the Pacific: the indications of the chromosome numbers*. *Ethnology*, 7, 1968, 259–267.

# Giant Swamp Taro, a Little-Known Asian-Pacific Food Crop

Donald L. Plucknett<sup>1</sup>

*Cyrtosperma chamissonis* (Schott) Merr., a member of the *Araceae* and probably native to Indonesia, has now spread eastward to become a minor crop in the Philippines, Papua New Guinea, and some Pacific Islands, but a major crop on coral atolls and low islands of the Pacific. A hydrophyte, and extremely hardy perennial, it grows in coastal marshes, natural swamps, and man-made swamp pits in conditions unsuitable for other staple crops. Yields vary, but 10–15 metric tons of the large edible corms per hectare per year have been produced. There is a great need to collect and evaluate cultivars now in use for salinity and flooding limits, short crop duration, superior food value and acceptance, and other factors, before they are lost through neglect.

Recently, interest in subsistence tropical food crops has increased. Root crops have

benefited from this new emphasis on indigenous staple foods.

---

<sup>1</sup>Soil and Water Management Division, Office Agency for International Development, Washington College of Tropical Agriculture, University of Agriculture, Technical Assistance Bureau, Washington, D.C., USA 20523. (Permanent address: Hawaii, Honolulu, Hawaii, USA 96822).

Some roots crops, however, are so poorly known or understood that they continue to be neglected. *Cyrtosperma chamissonis* (Schott) Merr., commonly called giant swamp taro, is such a crop. The only cultivated member (if *C. merkusii* is a separate species, then there are two cultivated species) of a pantropic genus of

Araceae found in Africa, Asia, and America, *Cyrtosperma* is grown mostly in the Pacific Islands and in some parts of Indonesia, the Philippines, and Papua New Guinea. It is most important as a food crop in the atolls and islands of the Pacific, where intricate systems have been devised to grow it (Massal and Barrau 1956; Barrau 1961; Kay 1973). Because it is extremely hardy and can be grown in fresh or brackish water swamps, it fulfills a need to find crops suitable for suboptimal conditions on marginal lands (Plucknett 1970, 1975, 1976).

Despite its importance, little is known of *Cyrtosperma*, and probably only ethnobotanists, anthropologists, and a few local agriculturists have studied its management. This paper will summarize the state of knowledge about the crop as well as to suggest some research needs.

### Early History

*Cyrtosperma chamissonis* probably originated in Indonesia, from where it spread eastward in prehistoric times to the Philippines, Papua New Guinea, and the islands of the South Pacific, to become a minor crop in Melanesia and Polynesia, but a major crop in Micronesia (Plucknett 1976). It is probably the most important staple food crop of the coral atolls. Although probably introduced to French Polynesia in the post-European discovery era (Barrau 1971), it is now grown in the following countries or islands: Indonesia, Philippines, northern coasts of Papua New Guinea, Solomon Islands, Fiji, Tahiti, Cook Islands, Tokelau Islands, Samoa, Palau Islands, Yap, Truk, Ponape, Marshall Islands, Caroline Islands, Gilbert Islands, and the Marquesas Islands (Brown 1931; Parham 1942; Massal and Barrau 1956; Barrau 1957, 1971).

### Botany

A member of the Araceae, *Cyrtosperma* is classified as follows: Tribe *Lasiodeae*, and Sub-Tribe *Lasiiae*. Like most edible aroids, the taxonomy of the species is confused; synonyms or incorrect names for *C. chamissonis* are: *C. merkusii* (Hassk.) Schott (this may be the correct name for the large Asian species, whereas *C. chamissonis* is thought to be the Pacific species; personal communication, Dr Dan Nicolson, Smithsonian Institution, Washington, D.C., USA), *C. edule* Schott, *C. nadeau-*

*dianum* Moore, *Apeveoa esculenta* Moerenhout, *Arisacontis chamissonis* Schott, and *Lasia merkusii* Hassk. (Barrau, 1957, 1959). It is often confused with *Alocasia*, and has sometimes even been confused with *Xanthosoma*.

*Cyrtosperma chamissonis* is a giant perennial herb (Fig. 1), ranging from 1 to 6 m (mostly 2 to 3 m) in height; the erect leaves, 6–8 at a time, are hastate-sagittate, with long acute basal lobes, dark green, and shiny; the petioles are thick, long, cylindrical, tapering toward the tip, often spiny near the lower parts, attached at the base in a spiral arrangement to the large corms; the spadix is purplish, tubular, covered with an open spathe which tapers near the tip; the flowers on the spadix are hermaphroditic; the fruit is a berry, and seeds are sometimes fertile; the main stem is a short, thick, branched, somewhat cylindrical corm resembling a banana rhizome that is large, ranging in size to as much as 1–2 m in length and 0.3–0.6 m in width, and in weight from 4 to as much as 100 kg or more; the cormels, which produce sucker shoots, arise from buds on the large central corm (Brown 1931; Barrau 1957; Massal and Barrau 1956; Pancho 1959).

### The Crop Itself

Cultivars vary widely in size, leaf shape and size, spininess of petiole, time to maturity, and colour or colour patterns of various plant parts, including the flesh of corms.

*Cyrtosperma* is primarily a tropical plant, its limits as a crop being about 18°N (Mariana Islands) to 20°S (Cook Islands). Probably originally a plant of coastal swamps or lower elevation rain forests, it is grown mostly near sea level in coastal marshes, natural swamps, or man-made swamp pits. It requires abundant water, but can grow under moderate rainfall in deep swamps with partial shade (Sproat 1968). Under year-round high rainfall it may be grown as a rainfed crop to elevations of 150 m or so; however, it is in the low swamps that the crop is most important, for its relatives — *Colocasia*, *Xanthosoma*, and *Alocasia* — are more successful as rainfed upland crops.

*Cyrtosperma* can withstand flooded conditions unsuitable for other food crops and grows better under continuous flooding than most varieties of *Colocasia* or rice. Additionally, it tolerates brackish water, although it is not



Fig. 1. Farmers and a *Cyrtosperma chamissonis* plant on Yap Island in the Pacific; in the centre of the picture are setts or cuttings of *Cyrtosperma* (right) and *Colocasia* (left) which have been prepared for planting. The cylindrical corm, large petioles, and characteristic hastate-sagittate leaves of *Cyrtosperma* are clearly illustrated (Photograph courtesy of Edward De la Cruz).

certain just what its limits of tolerance to salinity are. Cultivars should be studied to determine their salinity tolerance.

On Malaita in the Solomon Islands *Cyrtosperma* is grown in coastal swamps just behind the fringing mangrove swamps (Barrau 1958). It is grown on some of the high islands of the Pacific, but it is on the low islands or coral atolls that the crop reaches its maximum importance, mostly because it is one of the rare food plants that can grow and yield under the difficult conditions prevailing there. Here the soils, if any, are shallow and consist mostly of sand or partially decomposed coral rock. To create a suitable environment, the people dig pits or trenches down through the coral to the freshwater lens. They haul in soil, sand, and compost — coconut leaves, refuse, green manures, animal manure, and other vegetative matter — to create a growing medium. Over the years these man-made pits develop a soil of sorts in which, when supplemented with further vegetative mulches, crop residues, and garbage, *Cyrtosperma* and *Colocasia* are grown. Such pits are found in the Mortlock Islands, the Gilbert Islands, the atolls of the

Ponape District, Yap, Palau, Truk, and the southern Marshall Islands (Sproat 1968).

Sproat (1968) states: "Ideal growing conditions would be natural swampland rich in humus about two to four feet in depth with slow running irrigation water."

### Planting

*Cyrtosperma* is propagated vegetatively, using setts (cuttings) and young cormel shoots (suckers) that are separated from the base of the mother plant. Setts (sometimes called stalks) are prepared from the tops of harvested plants; these consist of the upper 3–5 cm of the tip of the corm, plus the lower 0.3–0.5 m of the petioles (Fig. 1). In Ponape, the people consider that setts should not be cut from plants in which the base of the clustered petioles is less than 4 cm or so in diameter. Larger setts are considered stronger and more vigorous.

*Cyrtosperma* can be planted year-round, provided that satisfactory growing conditions prevail. Planting is done by hand, by inserting the setts or suckers into the soft mud of the swamps. Planting depth varies, but 10–15 cm is probably fairly standard.

For nonpuddled or firmer soils, planting holes or furrows may be prepared using a digging stick to prepare individual holes, or shovels or similar tools to prepare furrows. Furrows may be 15–25 cm to as much as 1 m deep. After emplacing the setts or suckers in the furrows, the furrows are partially filled with soil to the desired depth for the planting material used.

### Spacing

Growing conditions and cultivar size greatly influence the plant spacings that are used. *Cyrtosperma* is a large plant, and it requires a fairly large area in which to grow. Also, because the crop may require from 2 to 6 years to mature, two or three crops of *Colocasia* are often intercropped with *Cyrtosperma* while the latter crop is growing.

Spacings vary; from 1.2 × 1.2 m (Palau); 0.4–0.6 × 1–1.3 m (Ponape district atolls); 1 × 1–1.1 m (Truk); 0.6 × 1 m (Ponape); to as close as 0.6 × 0.6 m in Yap where corm yields are highest and the crop is very important.

### Plant Nutritional Requirements

Little is known of the nutritional needs of

Table 1. Relative nutritional value, per 100 grams of edible portion of corms, of *Colocasia esculenta* and *Cyrtosperma chamissonis* (Murai et al. 1958).

Nutritional factor	<i>Colocasia</i>	<i>Cyrtosperma</i>
Calories	153	131
Protein (g)	1	0.9
Carbohydrate (g)	37	31
Calcium (mg)	26	334
Phosphorus (mg)	51	56
Iron (mg)	1.0	1.2
Thiamine (mg)	0.092	0.045
Riboflavin (mg)	0.030	0.074
Niacin (mg)	0.85	0.88

*Cyrtosperma*, but it is known that the plant responds readily to composts and organic mulches. It is a large plant with a long crop duration, and its nutritional requirements may be high. This needs study.

### Crop Duration

Long crop duration is one of the major limitations of the crop, which varies from 1 to 6 years or more in length, with 2 years being about the average harvest date for most South Pacific cultivars. However, shorter-term cultivars exist, and these should be exploited to the extent possible. For example, the island of Kusaie has 4 cultivars in which harvesting may begin as early as 6 to 12 months after planting.

### Harvesting

*Cyrtosperma* is hand harvested. Corms vary greatly in size, from an average 2 kg in Truk and 4.5 kg in Yap, to as high as 20–50 kg or more for the longer-lived giant types. The largest corm recorded appears to be one in Ponape that weighed about 180 kg, and that required 12 men to lift the whole plant from a swamp (Ponape Agriculture Demonstration Station 1950).

Recorded yields in various areas are as follows: general, 10 metric tons/ha/year (Kay 1973); Truk, 15.9 metric tons/ha/crop (unspecified crop period); Yap, 120 metric tons/ha (four year average crop duration, close spacing). This equals 30 metric tons/ha/year; Palau, 42.5 metric tons/ha/crop (unspecified crop periods); and Micronesia, 13.4–16.8 metric tons/ha/year (Sproat 1968).

### Pests and Diseases

*Cyrtosperma* is reputed to be practically free

of insect and disease attack (Sproat 1968). It is certainly true that the crop receives little management attention in many places where it is grown, and that it is extremely hardy.

### Food Uses

*Cyrtosperma* is grown mainly for its starchy corms, which are prepared much like *Colocasia*. Corms can be peeled and boiled in water, or peeled, chopped, and cooked with coconut milk. They also may be roasted or steamed. Sometimes corms are peeled, scalded, chopped, sun-dried, and stored for a few months (Massal and Barrau 1956; De la Cruz 1973). Recipes and food uses are given in Owen (1973), Sproat (1968), De la Cruz (1973), Murai et al. (1958), and Gesmundo (1932).

Leaves and young inflorescences are used as vegetables (Kay 1973). The petioles yield a fibre that can be used in weaving.

### Food Quality

*Colocasia* and *Cyrtosperma* are about equal in carbohydrates and calories, although *Cyrtosperma* has about twice as much fiber as *Colocasia* (Murai et al. 1958). Table 1 contrasts the relative nutritional value of *Colocasia* and *Cyrtosperma*.

Special thanks are extended to Professor Juan V. Pancho of the University of the Philippines at Los Baños for providing valuable assistance and support for field work in the Philippines and to Dr. Dan Nicolson of the Smithsonian Institution, Washington, D.C., USA for taxonomic help on *C. chamissonis* and *C. merkusii*.

This paper is published with the approval of the Director of the Hawaii Agricultural Experiment Station as Journal Series No. 2029.

- Barrau, J. *Les Aracees a tubercules alimentaires des Iles du Pacifique Sud*. Journal d'Agriculture Tropicale et de Botanique Applique, 4, 1957, 34-51.
- Subsistence agriculture in Melanesia*. Bernice P. Bishop Museum, Honolulu, Hawaii, Bulletin 219, 111 p, 1958.
- The sago palm and other food plants of marsh dwellers in the South Pacific islands*. Economic Botany, 13(2), 1959, 151-162.
- Barrau, J. *Subsistence agriculture in Polynesia and Micronesia*. Bernice P. Bishop Museum, Honolulu, Hawaii, Bulletin 223, 94 p, (reprinted in 1971 by Kraus Reprint Co., New York), 1961.
- Barrau, J. *Useful plants of Tahiti*. Société des Océanistes, Paris, Dossier 8, 33 p, 1971.
- Brown, F. B. H. *Flora of southeastern Polynesia. I. Monocotyledons*. Bernice P. Bishop Museum, Honolulu, Hawaii, Bulletin 84, 128-136, 1931.
- De la Cruz, E. T. *Root and tuber crops of the Trust Territory of the Pacific Islands*. Proceedings of the 2nd International Symposium on Tropical Root and Tuber Crops. College of Tropical Agriculture, Honolulu, Hawaii. Volume II, 77-86, 1973.
- Gesmundo, A. E. *The nutritive value of "gallan", Cyrtosperma merkusii (Hassk.) Schott*. Philippine Agriculturist, 21, 1932, 106-126.
- Kay, D. E. (Mrs). *Root crops*. Tropical Products Institute, Foreign and Commonwealth Office, London, TPI Crop and Product Digest No. 2, 245 p, 1973.
- Massal, E., and Barrau, J. *Food plants of the South Sea Islands*. South Pacific Commission, Noumea, New Caledonia, Tech. Paper 94, 51 p, 1956.
- Murai, Mary, Pen, Florence, and Miller, Carey D. *Some tropical South Pacific island foods*. University of Hawaii Press, Honolulu, Hawaii, 89-99, 1958.
- Owen, Hera Ware. *Bat soup and other recipes from the South Seas*. Graphics Press, Seattle, Washington, 49 p, 1973.
- Pancho, Juan V. *Notes on the cultivated aroids in the Philippines. I. The edible species*. Baileya, 7(3), 1959, 63-70.
- Parham, B. E. V. *Some useful plants of the Fiji Islands*. Fiji Agricultural Journal, 13(2), 1942, 40-41.
- Plucknett, Donald L. *Alocasia, Amorphophallus, Colocasia, Cyrtosperma, and Xanthosoma*. Proceedings of the 2nd International Symposium on Tropical Root and Tuber Crops. College of Tropical Agriculture, Honolulu, Hawaii. Volume I, 127-135, 1970.
- Current outlook for taro and other edible aroids. Report of Regional Meeting on the Production of Root Crops; Suva, Fiji, Nov. 24-29, 1975. South Pacific Commission, Noumea, New Caledonia (in press), 1975.
- Edible aroids*. In Simmonds, N. W., ed., Crop plant evolution, Longmans, London, 10-12, 1976.
- Ponape Agricultural Demonstration Station. *Annual report, 1949-50*. Agricultural Extension Service, University of Hawaii, Honolulu, Hawaii, 34 p, 1950.
- Sproat, M. N. *A guide to subsistence agriculture in Micronesia*. Division of Agriculture, Trust Territory of the Pacific Islands, Saipan, Mariana Islands, Agricultural Bulletin No. 9, 142 p, 1958.

# A Review of Sexual Propagation for Yam Improvement

Sidki Sadik<sup>1</sup>

The development of methods to germinate seeds now make it possible to improve white yam (*Dioscorea rotundata*) through sexual propagation. Previous difficulties in seed germination resulted from the failure to recognize a 3–4 month dormancy period, and because many seeds lack well developed embryo and endosperm. At the end of dormancy, seeds germinate in 3 weeks. Since 1973, about 40 000 genotypes have been produced through sexual propagation. This provides a wide range of genetic diversity to improve yam by selection for desirable characteristics.

Genetic diversity in white yam (*Dioscorea rotundata*) has been narrow and hopelessly inadequate for plant improvement. This has resulted primarily from lack of hybridization,

and continuous vegetative propagation. Yam breeders have long recognized this limitation and its adverse effect on yam improvement. As a result, all improvement efforts have been devoted to selection among the small number of existing cultivars. Attempts to improve the crop by selection, however, have proven futile,

---

<sup>1</sup>International Institute of Tropical Agriculture, P.M.B. 5320, Ibadan, Nigeria.

judging by the slow rate of improvement and the resulting decline in yam production during recent years.

Lack of hybridization and its adverse consequences were recognized as the most important limiting factor for yam improvement through breeding at the International Institute of Tropical Agriculture (IITA), when the Root and Tuber Improvement Program was initiated 6 years ago. It was believed then that unless hybridization could be accomplished, little contribution could be made over what previous breeders had done.

With that in mind, research on yam improvement at IITA was set out to identify and solve the problems and overcome the constraints that prevent yam hybridization.

### Constraints

Many factors contribute to lack of hybridization. The following, however, are the most important:

**Flowering** — Many of the important yam species cultivated for their edible tubers do not flower, and among plants that flower, there is a high male-to-female ratio. In West Africa, only a small number of *D. rotundata* plants established through vegetative propagation flower. In other regions, such as the Caribbean, flowering has not been reported although it may exist. Some *D. alata* cultivars flower abundantly and produce both male and female plants, but fruit production according to Martin (personal communication, 1975) is extremely rare and none of the fruits contain seed. Work by Rao et al. (1973) suggests that although *D. alata* flowers, fruits and seeds are not obtained because of hexaploidy. Flowering of *D. esculenta* has not been reported in West Africa or elsewhere. *D. cayenensis*, an important yam in West Africa, flowers occasionally, but produces only male flowers. *D. dumetorum* produces both male and female plants and abundant fruiting, however seed germination is yet unknown and requires investigation. *D. bulbifera* and *D. trifida* flower profusely and produce viable seed (Henry 1967).

**Pollination, fertilization, and incompatibility** — Because of the dioecious nature of yam and the smallness of flowers, pollen transfer from male to female plants can be a problem. Hand pollination is possible, but not practical. Due to the sticky nature of pollen grains and their strong adherence to anthers, wind pollination

is not possible, and therefore it is believed that pollen is transferred by night insects (Coursey 1967) or by small insects such as thrips, *Larothrips dentipes* (Pitkin 1973). In addition to the physical difficulty of pollen transfer from male to female plants, the viability of pollen grains is poor and certain inter- and intra-specific barriers may exist that result in pre- or post-ovular breakdown and embryo abortion (Rao et al. 1973).

**Seed germination** — Despite flowering scarcity and difficulties encountered during pollination, fertilization, and seed development, a small number of fruits with fertile seeds can be found occasionally on *D. rotundata* plants in farmers' fields in West Africa and elsewhere. Many attempts over the years to germinate such seed to produce plants with greater genetic diversity were only partially successful and were abandoned because of the common belief that the seeds were not viable. Such belief almost became accepted as fact and researchers were discouraged from pursuing further research on seed germination after the work of Waitt in 1959.

Since 1973, however, Sadik and Okereke (1975) have germinated *D. rotundata* seeds on a large-scale basis and have produced more than 40 000 genotypes. Other workers, since then, have successfully germinated seeds and their progenies have been used for selection (Doku 1973; Okoli 1975).

### Seed Germination and Seedling Establishment

Sadik and Okereke (1973) discovered two major factors limiting seed germination of *D. rotundata*. First, a large number of seeds are not viable because they lack well developed embryo or endosperm; and second, seeds have a dormancy period of about 3–4 months following harvest. The nature of the dormancy period has not been identified, but preliminary studies suggest that it is an after-ripening rest period. Methods for breaking the dormancy period have not been found and therefore storage of seeds at room temperature for 3–4 months is the only available way to overcome dormancy.

The method adopted for seed germination and seedling establishment can be summarized as follows: Fruits are collected from plants after maturation, during November–December in West Africa. Fruits are air-dried and split to

Table 1. Fruit and seed production of *D. rotundata* plants.

Family	Number of plants	Fruit per plant	Estimated number of seeds <sup>a</sup>
<i>1974 Harvest</i>			
Ihobia	13	40	2068
Boki	140	180	100632
Mixed	66	127	33636
<i>Total</i>	219	156	136336
<i>1975 Harvest</i>			
Umidike	143	368	210664
Boki	71	207	58900
Iwo	147	167	97908
Mixed	45	140	25148
Ihobia	7	81	2264
Ihobia (Veg.)	93	44	16324
<i>Total</i>	506	203	411208

<sup>a</sup>Based on 4 seeds per fruit.

release seeds. Seeds are dewinged and stored at room temperature until the end of dormancy. Seeds are then lightly and uniformly coated with a suitable fungicide and germinated on water-soaked filter paper in Petri dishes. Seed dewinging is not necessary, but reduces the amount of planting space needed in Petri dishes and prevents browning of filter paper during germination. Germination usually starts after 3 weeks and continues for 5 weeks. Germinated seeds are transplanted to peat pots following the appearance of the first leaf and grown until 2–3 leaves develop before they are transplanted in the field.

This method can be simplified by sowing seeds directly in peat pots or in germination boxes filled with soil-mix rich in organic matter. Seedlings established in this way can be transplanted later in the field.

Where laboratory and greenhouse facilities are not available, seeds can be planted directly in elevated seed beds. The seed bed should be protected from heavy rains by a 1 m high bamboo canopy covered with palm leaves. Seeds are planted densely in rows 10 cm apart and lightly mulched to avoid soil crusting. Seedlings are later thinned to 5 cm spacing between plants. Sufficient planting material for one hectare of land can be produced from a 100 m<sup>2</sup> area.

Seeds can also be planted directly in the field, eliminating the need for transplanting. However, special care must be taken to mulch and protect seeds and young seedlings from heavy rains and soil crusting.

It is important to treat seeds with a suitable fungicide before planting. Six disinfectants (Demosan, Demosan T, Vitavax, Argosan, Arasan, and calcium hypochlorite) were evaluated by Sadik (1975) to find a suitable chemical for treating seeds before planting. All chemicals other than calcium hypochlorite inhibited seed germination. A 10% w/v calcium hypochlorite solution produced 85% germination with only 5% rot (root and shoot development in the seedlings was good). Agrosan, a systemic fungicide prevented seed rotting and germination as well. The most effective method is to soak seeds for 20 minutes in calcium hypochlorite solution. However, because wet seeds are difficult to work with, fungicides that can be applied in powder form are preferable and require further investigations.

## Flowering

A low degree of flowering (47%) and a high male-to-female ratio (32/15) characterize plants produced through continuous vegetative propagation. In contrast, second-generation plants produced from seed are characterized by a higher degree of flowering (80%) and a lower male-to-female ratio (41/35). Whereas plants produced through continuous vegetative propagation are normally dioecious, lines originating from seed produce a large number of monoecious plants (4%), which are a useful addition to any yam breeding program. There is also an increase in the number of flowers produced by sexually propagated,

second generation plants. Sexually propagated plants usually produce 500–90 000 flowers per male and 500–11 000 flowers per female plant, whereas 185 female flowers is the common maximum on vegetatively propagated plants.

### Fruit and Seed Production

The formation, development, and retention of fruits on vegetatively propagated female plants are low. Studies during 1972 revealed that the number of retained fruits on vegetatively propagated plants did not exceed 24 per plant with a potential production of 5–7 filled seeds per plant. The number of fruits retained on sexually propagated plants, studied during 1974 and 1975, was greater, and exceeded 2000 fruits on some plants (Table 1).

### Tuber Yield

Because of seed dormancy it is impossible during the first year to produce seedlings ready for field transplanting at the normal April planting time. During 1975, seedlings were transplanted in the field between June 15 and July 15, which only allowed a 4–5 month growing period, too short to produce large tubers. Despite that, tubers up to 1 kg were produced. It would be interesting to find the yield potential of plants grown from seed if the seedlings could be transplanted in April. An answer to that should be possible in the future when old seeds that have passed their dormancy are germinated in time to be transplanted in the field during April.

Yields of sexually propagated, second-generation plants ranged from 0.1–8.7 kg/plant during 1974, whereas some plants yielded up to 25 kg/plant during 1975. During both years, flowering plants outyielded nonflowering plants, and female plants outyielded male plants.

### Genetic Diversity

Sexually propagated plant populations exhibited a wide spectrum of genetic diversity during the first year. Further intercrossing between such plants increased the genetic diversity even more. Some of the most important genetic variabilities observed are as follows:

*Plant height and vigour* — Yams are vine plants with poor stem structures that necessitate staking. In West Africa, staking accounts

Table 2. Vigour and canopy structure among plants of *D. rotundata* derived from seed.

Canopy	Number of plants	Percentage
High vigour	4685	32.5
Medium vigour	2909	20.1
Low vigour	6235	43.2
Dwarf	586	4.1
Semidwarf	13	0.1
Total	14428	100.0

for almost 20% of production inputs. The advantage of selecting short and sturdy yam plants that do not require support is obvious. As a result of sexual propagation, about 4% of the plants were dwarf and did not require mechanical support. These plants produced many stems and small tubers with a maximum weight of 200 g/tuber. Small tubers are commercially undesirable at present, but such plants can be used in breeding programs to change plant height and canopy structure.

Plants produced through sexual propagation exhibit a high degree of variability in vigour (Table 2), which presents opportunities for selection within and among families.

*Vegetative variability* — A wide range of leaf and stem shapes, sizes, colours and other minor characteristics was observed. Variability in tuber size, shape, furcation, hairiness, rugosity, and flesh colour was also observed. It is difficult to determine the desirable characters for plant improvement before obtaining basic information on the importance of these genetic characters and their contributions to yield.

*Reproductive variability* — Sexually propagated plants presented a wide spectrum of variability in date and degree of flowering, sex expression, inflorescence shape and length, fruit size, shape, and colour, and seed size, colour, and dormancy.

*Disease resistance* — Sexually propagated plants manifested marked variability in resistance to major diseases present at IITA.

### Seed Storage

Seed viability deteriorates during storage at ambient temperatures, and germination drops to 30–40% one year after harvest. During 1975 a study to find suitable conditions to store seed for at least 3 years without appreciable loss of viability was started.

Seed germination was tested monthly during the first 8 months of storage at six conditions. Cold-storage treatments especially, when combined with desiccation, reduced the percentage of germination and increased the number of days to the onset and to 50% germination. Storage at 25 °C without silica gel resulted in the highest germination rate and the least number of days to the onset and to 50% germination, whereas storage at 25 °C over silica gel resulted in opposite results. Although germination of seed stored at 25 °C for 8 months is superior to that at cold storage, the long-term effect of cold storage is not yet known.

### Research Needs

The opportunities to improve yams through hybridization have been greatly enhanced by increasing flowering and by achieving seed germination. However, many problems remain before further advancements can be made. Although flowering has been improved quantitatively and qualitatively, methods for inducing flowering in nonflowering plants and species must be found before the genetic resources of such plants can be utilized. Studies of the barriers that prevent inter- and intra-specific hybridization are also urgently needed.

Conserving yam germ plasm in tuber form is difficult and undesirable because of the great bulk, poor storability, and the possibility of disease- and pest-transmission from one crop to another. Because of these factors, quarantine regulations restrict the movement and exchange of germ plasm among research workers. Germ plasm can be conserved and exchanged through seeds that are less bulky, not restricted by quarantine regulations, and contain more genetic diversity for selection. However, before

this can be recommended, work should be conducted to find suitable conditions for storing seed, to develop methods to break seed dormancy, and to present strong evidence that disease and pests are not seed-borne.

These are some of the problems that need urgent attention to maximize opportunities to improve yams through hybridization and sexual propagation.

Coursey, D. G. *Yams*. Longmans, London, 1967.  
Doku, E. V. *Sexuality and reproductive biology in Ghanaian yam (Dioscorea spp.) cultivars. 1. Preliminary studies*. Paper presented at the Third International Symposium on Tropical Root Crops, Ibadan, Nigeria, Dec. 2-9 (in press), 1973.

Henry V. C. R. *Studies on botanical and agronomic characteristics of cush-cush (Dioscorea trifida L.F.)*. Ph.D. thesis, McGill University, Montreal, Canada, 1967.

Okoli, O. O. *Yam production from seeds, prospects and problems*. Paper presented at the 11th Annual Conference of the Agricultural Society of Nigeria, Enugu, Nigeria, July 1-15 (in press), 1975.

Pitkin, B. R. *Larothrips dentipes (Thysanoptera, thripidae), a new genus and species of thrips from yam flowers in Nigeria*. Bull. Ent. Res. 62, 1973, 415-418.

Rao, V. R., Bammi, R. K., and Randhawa, G. S. *Interspecific hybridization in the genus Dioscorea*. Ann. Bot. 37, 1973, 395-401.

Sadik, Sidki. *IITA Annual Report*. IITA, Ibadan, Nigeria (in press), 1975.

Sadik, Sidki, and Okereke, O. U. *A new approach to improvement of yam Dioscorea rotundata*. Nature, 254(5496), 1973, 34-135.

*Flowering, pollen grain germination, fruiting, germination and seedling development of white yam, Dioscorea rotundata Poir*. Ann. Bot. 39, 1975, 597-604.

Waitt, A. W. *Report on Agricultural Research in Nigeria 1957-58*. Federal Government Printer, Lagos, Nigeria, 18-19, 1959.

# Selected Yam Varieties for the Tropics

Franklin W. Martin<sup>1</sup>

This 8-year program for selecting better yam (*Dioscorea*) varieties for the tropics includes: a worldwide collection of varieties of the principal species; the development of techniques to evaluate varieties agronomically, and for culinary and processing characteristics; the selection and testing of varieties; and the distribution of selected varieties throughout the tropics. In addition, composition with respect to proteins and starch was

---

<sup>1</sup>Mayaguez Institute of Tropical Agriculture, Box 70, Mayaguez, Puerto Rico.

determined, and the nature of the yellow pigments and the bitter substances was elucidated. Taxonomic relations were clarified by numerical computerized techniques. *Dioscorea alata* was judged the most flexible and useful species, and 17 selected varieties were obtained. *Dioscorea esculenta* was found to be much more variable than expected, and 8 varieties were selected for their high potential. On the other hand, persistent problems with viruses prevented the distribution of *Dioscorea rotundata* - *D. cayenensis*. In addition, this species complex appears to be narrowly adapted.

The edible yams of the tropics, of which there are 50 or more species, have hardly left their original homes to serve mankind. To be sure, edible yams are found in every part of the tropics where they can be grown. Nevertheless, distribution has been accomplished haphazardly. The cultivars present in any particular region are often inferior to the better ones known elsewhere. Furthermore, the introduction of better cultivars has been impeded by a lack of published information. The result has been that yams are not as widely utilized as their potential merits.

To remedy this situation the U.S. Agency for International Development suggested a program of collection and distribution of yam varieties. Collections were begun in 1969 at the Mayaguez Institute of Tropical Agriculture. It became evident at that time that varieties easily available in the Caribbean were not representative of the full range of germ plasm, and that progress could only be made by collecting yams extensively on an international basis. It was also evident that we did not know enough about yams to define a good variety. Therefore, while USAID funded the collection and distribution phases of the program, MITA funded supplementary investigations as necessary.

The collection of yams was made over a period of several years through correspondence and through collecting trips. A visit to West Africa was financed by FAO, and one to Southeast Asia was financed by USAID. During these trips about 800 accessions of yams were acquired. I am indebted to many persons throughout the tropics for help in obtaining new varieties. Without qualified professional help in each location, the collecting expeditions would have been unsuccessful.

In Puerto Rico, newly introduced varieties were grown for a year or more in isolation from the principal collection, and were observed for pests and diseases. A system of evaluation based on morphological, agronomic, physiological, culinary, and processing characteristics was developed, and was adapted

to the different species. Criteria for selection were developed. Preliminary selections were tested for yields in replicated field trials.

This paper represents a summary of activities and findings, and includes plans up to the expected closing of the program in June 1977.

### **D. alata**

Of the various species of *Dioscorea* collected, the greater yam (*Dioscorea alata*) quickly became our favorite. Under the conditions where we have seen *D. alata* grown in Puerto Rico, it is the most dependable species, although some of its varieties are unreliable due to their susceptibility to *Colleotrichum*, *Cercosporum*, and other foliar diseases. *D. alata* often yields exceptionally well. Its tubers, if kept free of damage at harvest, can be stored about 5 months. We have stored tubers for 8 months or more by regularly eliminating shoots.

All varieties of the greater yam have certain traits in common. Their growing season is long (8-10 months). All require support for the vines. All can be established easily from any piece of the tuber. Regardless of planting time, all mature about the same time, with no more than a month of difference between the earliest and the latest varieties. I believe all are susceptible to virus disease, but the majority can be maintained symptom free by roguing and planting only from superior tubers.

During the study of the greater yam we found some unexpected differences. Yellow fleshed varieties were shown to contain nutritionally valuable amounts of carotene. Unusual varieties from Papua New Guinea showed the most fascinating shapes, consisting of a series of intersecting vertical planes. Varieties were found that were almost free of wings on stems and petioles, and in some cases leaves were principally alternate rather than opposite. Tuber characteristics were highly variable. Varieties that had reverted to the wild were found in Africa and in the West Indies. These were propagated exclusively from aerial

tubers. Very few varieties flowered, and fertile seeds were never produced during the 7-year study period.

The within-species relationships of the varieties were studied by numerical taxonomic techniques. About 235 of the 350 varieties we collected were used for this study, and 100 characteristics were noted. It was possible to classify varieties into 13 groups that were defined on the basis of character means. These groups were related to, but not identical with, certain geographical areas. Based on the amount and nature of variation seen, we concluded that Papua New Guinea was a centre of variation, and possibly the centre of origin of the species. The sympatric species *Dioscorea nummularia* resembles some of the *D. alata* cultivars found there. An unexpected finding was that the Caribbean and African varieties are somewhat related to each other, and that their affinities in Southeast Asia were not traceable with our materials.

Tubers of *D. alata* were found especially useful for processed products, including fries, chips, instant flakes, and flour. They were not suitable for the production of fufu. The tubers were usually rich in protein compared to roots and tubers of other species, and some exceptionally rich varieties were found. The proteins contained sufficient lysine but were always short of methionine.

A good variety of *D. alata* is resistant to leaf spot diseases and viruses, and is not affected adversely by excessive moisture. The tubers are borne in pairs or in threes, are spherical or cylindrical in shape, are not often branched, and have smooth but thickened skin that resists abrasion. The surface may have some fine roots, but the principal roots should be concentrated in the fibrous upper extreme of the tuber. Resistance to insects, diseases, and nematodes is desirable. Yields must be high and dependable, even when the crop is produced without support for the climbing vines.

Some special characteristics related to cooking are desirable. The parenchyma storage flesh should be white or cream coloured, and free of anthocyanin pigments. The "grain" of the tuber caused by starch accumulation around the vascular bundles should be fine, giving a compact and uniform appearance. After being cut or injured, or after prolonged storage, the flesh should not discolour readily by oxidation. The boiling time necessary to reach an acceptable softness may vary, but the better

varieties generally reach this stage rapidly. The cooking water should remain free of gray or pink pigments. The flesh of the boiled tuber may be white, cream, or light yellow, appetizing in appearance, and free from gray colour. It should appear to be smooth, and that appearance should be verified when tasted. The cooked tuber should be moist in the mouth; not dry and difficult to swallow. The taste should be rich and distinctive, neither too bitter nor too sweet.

In addition, the variety should produce good yields (20 t/ha or more), the tuber should store well and resist fungi, and the seed pieces should germinate readily when planted.

No varieties were seen that combined all desirable characteristics. Selection of new varieties thus became a matter of compromise.

Seventeen excellent varieties were selected for distribution. I believe that some of these will replace traditional varieties wherever they are grown. These 17 were obtained from widely diverse regions, including Fiji, the Philippines, Java, Malaysia, Papua New Guinea, India, Nigeria, Sierra Leone, and Puerto Rico.

### ***D. cayenensis* – *D. rotundata* Complex**

In contrast to *D. alata*, the collection of cultivars of *D. cayenensis* and *D. rotundata* was the most difficult to manage. We started with an excellent group of 220 introductions collected from Sierra Leone to Nigeria as well as local varieties found in the Caribbean. From the beginning many plants showed strong virus-like symptoms. This condition was the same as that called the shoestring disease in West Africa. There was no doubt that introductions showing such symptoms had been collected in all of the principal yam growing regions of Africa, and in the Caribbean. Our experience with this disease in Puerto Rico is that it reduces yields, sometimes drastically. The use of small tubers for replanting results in a more rapid spread of the disease, possibly because such tubers are found more frequently on diseased plants. Plantations grown under optimum conditions and rogued free of symptoms for 2 or 3 years become almost symptom-free. Constant vigilance appears necessary to maintain reasonably healthy materials.

Since most introductions were based on a single small tuber, it is no surprise that virus-like symptoms were often severe. Even in the

first planting, symptoms were found in all introductions. In an effort to preserve the germ plasm, all introductions were multiplied for 1 or 2 years before rogueing was begun. Prolonged heat treatment of tubers, sometimes found useful in reducing symptoms in *D. alata*, was not useful in the case of the African species.

When virus symptoms were not eliminated, a program of severe rogueing was begun. During the 2 years of rogueing, the majority of the varieties were eliminated. Furthermore, with time even the more resistant varieties have shown intolerable levels of the disease.

Given the circumstances, we have taken an extremely difficult decision. The African yam collection will not be distributed but will be eliminated. Three varieties that appear to be completely resistant to the virus disease will be tested in isolation for 2 more years, but it is unlikely that these will be used anywhere except on the island of Puerto Rico.

While working with this collection, we have written a production bulletin, analyzed the carotenoid pigments, and identified a bitter substance as leucoanthocyanidin. In addition, we have finished a study of the relationships of 97 cultivars using the techniques of numerical taxonomy. In that study the species complex is divided into nine groups that coalesce to form two principal trunks. One of these represents chiefly yellow tubered cultivars, the other represents chiefly white ones. It is interesting to note that the two trunks anastomose with respect to two groups that show similarities even though they differ in tuber colour. The conclusion from our study is that the two names *D. cayenensis* and *D. rotundata* reflect artificial classification of what is an extremely variable complex.

With respect to the work of the future with this species, we are convinced that, in the Caribbean, *D. alata* is better adapted and more reliable. But in West Africa even the best *D. alata* varieties may not be competitive with the African cultivars. In most parts of the world, these African yams have never had a real try. It appears to us that the breakthrough in seed production achieved at IITA by Sadik and others opens the door for a more extensive use of the African yams throughout the tropics. It would be highly desirable to introduce African yams as seed and to develop varieties for local adaptation. Seedlings that we have established from seeds sent to us by Sadik may not be

fully evaluated before our program terminates. Nevertheless, we believe the breeding work will continue at another experiment station in Puerto Rico. Obtaining virus-free varieties will not be enough. If resistance is not found, the job of keeping varieties free of virus will be formidable.

## D. esculenta

Of the species of *Dioscorea* we have worked with, perhaps *D. esculenta* is the least known. Nevertheless, we believe that it might have a real potential in the tropics. The habit of producing multiple tubers not unlike potatoes is useful when machine harvest is contemplated. The small tubers are useful at the household level and are easy to handle if replanted. Some varieties, if handled carefully, store well. Furthermore, *D. esculenta* is probably more resistant to viruses than even *D. alata*. The chief disadvantage with respect to *D. esculenta* is that the growing season is long, almost 12 months. I believe that it might be possible to plant and harvest *D. esculenta* at any time of the year in some regions near the equator. Nevertheless, *D. esculenta* is fussy about season. Its period of dormancy is not very flexible, and indeed we have had problems in adjusting varieties from the southern hemisphere to 18°N in Puerto Rico. The wide variation among cultivars of *D. esculenta* has never been described, but has at least been hinted at, in the literature. Varieties from Papua New Guinea, the presumed centre of origin, have been carried to some islands of the Pacific but apparently in a random fashion. Although I was able to collect a wide variety of cultivars from the regions, I have no doubt that much remains to be done to entirely describe this species.

The West African and Caribbean cultivars of *D. esculenta* bear about 20–50 relatively small tubers that range from mere swellings to about 400 g in size. Their flesh is white and their eating qualities are high. In contrast, some varieties of *D. esculenta* in Papua New Guinea bear 6 or 8 tubers up to 2 kg in weight. The largest tuber I have seen was the shape and size of a small watermelon, and weighed about 5 kg. In general the flesh of these large tubers is somewhat coarse and subject to polyphenolic oxidation. Between the extremes there are many interesting varieties that bear intermediate sized tubers of good quality. Some of

these have been selected for distribution in January or February of 1977.

In Papua New Guinea one also encounters many primitive varieties, often with small, branched, or irregular tubers. Flesh colour may be white, purple, or yellow. Thorniness of the roots surrounding the crown varies. An unexpected characteristic sometimes seen is the curling of the tuber toward the surface, and at times, the penetration of the surface by the tuber.

The starch grain of *D. esculenta* is fine compared to that of the principal species *D. alata* and *D. rotundata*. The amylose content of the starch is low, and the protein content of the tuber is extremely high in some cultivars.

*D. esculenta* merits a wider trial throughout the tropics, but only where growing season is long, and rainfall is abundant.

### Other Species

During the course of our studies we have had the opportunity to work with six other edible species. While finding some merit in all of them, and realizing that we have not seen all of the germ plasm available, we have rejected some of the species, as follows: *Dioscorea bulbifera*, about 100 collections. The tubers of this species are always bitter; *Dioscorea hispida*, about 15 collections. This species is poisonous and needs special treatment to render it harmless; *Dioscorea dumetorum*, about 12 collections. This is sometimes poisonous, and the tuber is very irregular; *Dioscorea nummularia* and *D. pentaphylla*. Tubers are large, irregular, sometimes multiple, and cooking characteristics are below par; and *Dioscorea trifida*, which is very susceptible to viruses. Yields decline rapidly when the virus appears.

### Literature Produced

As part of the research and development program 37 manuscripts were prepared for publication, and a few more are planned. The titles of these manuscripts are appended to this paper. Perhaps the major task was a review of modern production techniques, followed by detailed handbooks on the principal species. Within-species taxonomic relationships were studied in the case of the principal species. Nutritive values, especially protein and amino acid contents, were determined and yams were compared to other roots and tubers with re-

spect to their nutritive values. The composition of the flesh was analyzed with respect to carotenoids, polyphenols that oxidize, and bitter substances. Certain physiological characteristics were studied: the curing period, and how it affects storage life; the extension of storage life with chemical treatment; and the stimulation of sprouting. To develop standards of selection, fried chips, instant flakes, and flours were developed and tested. Superior selections were described. Plans call for a thorough review of written contributions and recommendations before terminating the program.

Reprints and planting pieces are available free to investigators throughout the tropics. Reprints, already in short supply, are sent out at time of request. Tubers are shipped each January or February. Shipments are furnished with phytosanitary certificates. Nevertheless, we recommend that tubers we distribute be quarantined for a year until shown to be disease and insect free.

### Manuscripts Concerning Yams

#### Published

- Martin, F. W., and Thompson, H. E. *Crude protein content of yams*. Hort. Sci. 6, 1971, 545-546.
- Martin, F. W. *Yam conservation problems*. Plant Genetic Resources Newsletter 28, 1972, 35-36.
- Martin, F. W. *Yam Production Methods*. USDA Agricultural Research Service Production Research Report No. 147, 1972, 17 p.
- Martin, F. W., and Ruberté, R. *Yams (Dioscorea spp.) for production of chips and french fries*. J. Agric. Univ. Puerto Rico 56, 1972, 228-234.
- Rhodes, A. M., and Martin, F. W. *Multivariate studies of variations in yams (Dioscorea alata L.)*. J. Amer. Soc. Hort. Sci. 97, 1972, 685-688.
- Rodríguez-Sosa, E. J., González, M. A., and Martin, F. W. *Evaluation of ten varieties of yam (Dioscorea spp.) for production of instant flakes*. J. Agric. Univ. Puerto Rico 56, 1972, 235-243.
- Martin, F. W. *Yam (Dioscorea spp.) in West Africa*. In Frankel, O. H., ed., Survey of crop genetic resources in their centres of diversity. Food and Agriculture Organization of the United Nations, and International Biological Program, 1973, 65-67.
- Martin, F. W. *Review of: Anatomy of the monocotyledons. VI Dioscoreales*. By Ayensu, E. S., and edited by Metcalfe, G. R. Carendon Press, Oxford, Quarterly Review of Biology 48, 1973, 37-38.
- Martin, F. W., and Rhodes, A. M. *Correlations among greater yam (Dioscorea alata L.) varie-*

- ties. *Tropical Agric. (Trinidad)*, 50, 1973, 183-192.
- Martin, F. W., and Thompson, A. E. *Protein content and amino acid balance of yams*. *J. Agric. Univ. Puerto Rico*, 57, 1973, 78-83.
- Rodríguez, E. J., Cruz-Cay, J. R., González, M. A., and Martin, F. W. *Shelf-life study of Farm Lisbon (Dioscorea alata L.) yam chips*. *J. Agric. Univ. Puerto Rico*, 58, 1973, 196-202.
- Splittstoesser, W. E., Martin, F. W., and Rhodes, A. M. *Amino acid composition of yams as related to species and cultivars*. *J. Amer. Soc. Hort. Sci.* 98, 1973, 563-567.
- Splittstoesser, W. E., Martin, F. W., and Rhodes, A. M. *The nutritional value of some tropical root crops*. *Proc. Trop. Reg. Amer. Soc. Hort. Sci.* 17, 1973, 31-34.
- Telek, L., Martin, F. W., and Ruberté, R. M. *Bitter compounds in tubers of Dioscorea bulbifera L.* *J. Agric. Food Chem.* 22, 1974, 332-334.
- Martin, F. W., Telek, L., and Ruberté, R. *Yellow pigments of Dioscorea bulbifera*. *J. Agric. Food Chem.* 22, 1974, 335-337.
- Martin, F. W. *Tropical yams and their potential I. Dioscorea esculenta*. *Agric. Res. Ser. U.S. Department of Agriculture, Agricultural Handbook 457*, 1974, 18 p.
- Martin, F. W., Koo, F. K. S., and Cuevas, J. *Stimulation of yam (Dioscorea) tuber development by gamma irradiation*. *J. Amer. Soc. Hort. Sci.* 99, 1974, 282-284.
- Martin, F. W. *Curing yams before storage I. Wound types, species, and humidity effects*. *J. Agric. Univ. Puerto Rico*, 58, 1974, 211-218.
- Martin, F. W. *Tropical yams and their potential. II. Dioscorea bulbifera L.* *USDA Agricultural Handbook 466*, 1974, 20 p.
- Splittstoesser, W. E., and Martin, F. W. *The tryptophan content of tropical roots and tubers*. *Hort. Sci.* 10, 1975, 23-24.
- Martin, F. W., and Splittstoesser, W. E. *Protein and amino acid contents of tropical roots and tubers*. *Root and Tuber Crops Newsletter*, 8, 1975, 7-15.
- Martin, F. W., Cabanillas, E., and Guadalupe, R. *Selected varieties of Dioscorea alata L., the Asian greater yam*. *J. Agric. Univ. Puerto Rico*, 49, 1975, 165-181.
- Martin, F. W. *The storage of germ plasm of tropical roots and tubers in the vegetative form*. In Frankel, O. H., and Hawkes, J. G., eds., *Crop genetic resources for today and tomorrow*. Cambridge, London, 1975, 369-377.
- Martin, F. W., and Ruberté, R. *Carotenoid pigments of Dioscorea cayenensis*. *Ann. Appl. Biol.* 30, 1975, 317-322.
- Martin, F. W. *The edible yams. Roles for the future*. *J. Root Crops (India)*, 1, 1975, 51-54.
- Martin, F. W., and Ruberté, R. *The flours of edible yams*. *J. Agric. Univ. Puerto Rico*, 59, 1975, 255-263.
- Martin, F. W. *Tropical yams and their potential. III. D. alata*. *USDA Agricultural Handbook 495*, 1975, 40 p.
- Martin, F. W. *Southeast Asian yams and their potential*. In Williams, J. T., and Lamoureux, C. H., eds., *Plant genetic resources of Southeast Asia*. Bogor, Indonesia, 1975, 83-90.
- Martin, F. W., and Ruberté, R. *The bitterness of Dioscorea cayenensis*. *J. Agric. Food Sci.* 23, 1975, 1218-1219.
- Martin, F. W., and Ruberté, R. *The polyphenol of D. alata that oxidizes to brown*. *J. Agric. Food Chem.* 24, 1976, 67-70.
- Womack, M., Martin, F. W., and Vaughan, D. A. *Toxicity of some edible yams to rats*. *Tropical Root and Tuber Crops Newsletter*, 9, 1976, 27-32.

### Pending Publications

- Martin, F. W. *A collection of West African yams*.
- Martin, F. W. *The edible yams*.
- Martin, F. W., and Sadik, S. *Tropical yams and their potential. IV. Dioscorea rotundata and D. cayenensis*.
- Martin, F. W. *Stimulating the germination of yam tubers with ethephon*.
- Martin, F. W., and Rhodes, A. M. *The classification of Dioscorea alata varieties*.
- Cabanillas, E., and Martin, F. W. *Propagation of edible yams from stem cuttings*.
- Martin, F. W. *The tropical yams, their growth requirements and their potentials*.
- Martin, F. W., and Rhodes, A. M. *The relationship of Dioscorea cayenensis and D. rotundata*.

## Adaptation of Cultivated Potatoes to the Lowland Tropics

H. A. Mendoza<sup>1</sup>

An initial group of 6000 potato clones from various taxonomic groups was screened for adaptation to high temperatures and humidity at a high jungle site. Of these, 34 tetraploid clones were selected for further testing under three tropical environments in Peru. The sites represented a hot, irrigated location; a high, wet jungle; and a low, wet jungle.

The performance of some of the clones, in particular hybrids of *tuberosum* × *neotuberosum* and *tuberosum* × *phureja*, was remarkable given the short growing season and the stress imposed not only by the weather but also by weeds, insects, and diseases. The greater genetic diversity of the inter-group hybrids gave the genotypes a greater ability to adapt to conditions of stress than the intra-group hybrids. The results indicate that there is a genetic potential to adapt potatoes to high temperatures, and that for the first time it may be possible to economically grow potatoes in the lowland tropics.

The principal areas of cultivation of the potato are concentrated in zones of the world with cool to medium temperatures during the growing season. This condition is met both at low elevations in medium to high latitude countries as well as at high elevations in many tropical countries.

The type of germ plasm utilized in different production zones also varies with the influence of latitude on daylength and temperature. High latitude countries with medium temperatures and long photoperiods during the growing season use cultivars from the *tuberosum* group, whereas countries with low latitudes, high elevations, and cool temperatures use cultivars from the group *andigenum*, some *tuberosum* × *andigenum* hybrids, and to a lesser extent cultivars from other taxonomic groups.

The response of these various germ plasm groups when moved away from their native ecological niches is in general the same: a very low yield compared to local cultivars. Short day potatoes grown under long day, medium temperature conditions are extremely late, whereas most of the so-called day neutral potatoes grown under the short day and cool temperatures of the low latitude and high altitude environments are in most cases extremely early.

Attempts to cultivate potatoes in the lowland tropics have utilized only cultivars from the group *tuberosum*. Since *tuberosum* cultivars have been selected under higher temperatures than those prevalent at the centre of origin of the potato, they would be expected

to have more adaptation to warmer conditions than any other cultivated germ plasm. The stringent conditions that the potato meets in the lowland tropics are rather different to those present in the common areas of cultivation. Therefore, characteristics related to adaptation will have to be given much more emphasis during early stages of selection than certain agronomic characters.

The International Potato Center (CIP) has as one of its objectives to develop heat tolerant clones as a potential to expand the opportunities for potato cultivation in the warm lowland tropics, both dry and wet. This report provides the first data on the progress of the research program.

### Materials and Methods

Three testing sites in Peru were used in these experiments. La Molina, an arid area under irrigation that represents a dry, hot lowland tropic. San Ramon, a high jungle location where the common crops are cassava, fruit trees, coffee, and corn. Yurimaguas, a low jungle site in the Amazonian basin where the agriculture is a shifting system that uses cassava, rice, bananas, and tropical forages.

About 6000 clones from various diploid and tetraploid taxonomic groups as well as their intercrosses were evaluated at the San Ramon location during the period June–October 1974. From these, 34 tetraploid clones were chosen for their earliness and yield potential and were grown in replicated trials during December to February 1975 at San Ramon and La Molina. The same set of clones was grown later at Yurimaguas. The taxonomic groups in the pedigrees of the clones utilized in the experi-

<sup>1</sup>Breeding and Genetics Department, International Potato Center, Apartado 5969, Lima, Peru.

Table 1. Yields of representative clones.

Clone	Taxonomic group	Yield for 10 plants (kg)		
		San Ramon	La Molina	Yurimaguas
N565.1	(T × NT)	14.4	6.4	5.0
N574.1	(T × NT)	14.1	9.0	2.1
DTO-28	(T × P)	13.6	10.1	5.3
DTO-2	(T × P)	11.8	10.7	2.9
DTO-33	(T × P)	11.6	10.0	3.8
N570.5	(T × NT)	11.3	4.4	1.4
Urgenta	(T × T)	10.8	8.8	1.5
N503.162	(NT × NT)	10.7	8.5	1.2
N513.3	(NT × NT)	10.2	5.9	0.7
N545.3	(NT × NT)	9.1	3.8	1.1
ONA	(T × T)	6.7	8.6	1.2
Arran Pilot	(T × T)	6.3	7.8	1.5
Mariva	(T × A)	4.6	2.5	0.1
Revolucion	(T × A)	4.0	3.0	0.8
Inti Sipa	(A × A)	3.6	2.5	0.02
Mean <sup>a</sup>		8.2	6.8	1.7
LSD <sub>0.05</sub>		2.0	2.3	0.8

<sup>a</sup>A general mean per location for all 34 cultivars. LSD values have been calculated from the analysis of variance over all the clones at each site.

ments were: *tuberosum* × *tuberosum*, 4 clones; *tuberosum* × *phureja*, 16 clones; *tuberosum* × *neo-tuberosum* (*andigenum*), 5 clones; *neo-tuberosum* × *neo-tuberosum*, 6 clones; *tuberosum* × native *andigenum*, 2 clones; and native *andigenum*, 1 clone.

The experimental design at each location was a completely randomized block with two replications. Each plot had 10 plants.

## Results and Discussion

There was a great deal of variability in yield among clones within each location as shown in Table 1. Each environment represented a different level of stress as measured by differences in the overall means. The growing periods of 60, 75, and 90 days for the testing sites were not purposely chosen but were the length of time at which most of the clones were either mature or dead as a consequence of weather stress, insect and disease damage, or the combined effects of them.

Some of the main environmental components and their effects on or their interactions with the genotypes will be discussed.

### Photoperiod

The latitude of the testing sites (6, 11, and 12° for Yurimaguas, San Ramon, and La Molina, respectively) is fairly close. Daylength

at San Ramon and La Molina was the same, whereas at Yurimaguas it was about 20 minutes less. The genetic background of all the clones used in this work, except one, was day neutral or hybrids between day neutral × short day types. Any tuber-inducing differences of the photoperiod should either have been minimal or nil.

### Temperature and Water Supply

Temperature-wise the two jungle locations placed more stress on the plants than did La Molina. At Yurimaguas, temperatures were high and uniform, whereas at San Ramon it was somewhat cool during the night. However, in these two sites rainfall supplied moisture on a rather regular basis. Despite the fact that at La Molina both the maximum and the minimum temperatures were lower, the yield of most individual clones as well as the overall mean was lower than at San Ramon. Since the crop at La Molina was under surface irrigation, the moisture availability was not uniform and this appears to have had a stress effect on yield.

### Diseases and Insects

At La Molina, the principal problem was the attack by tuber moths, *Scrobipalpa absoluta* and *Pthorimaea operculella*, which caused considerable damage in the foliage and later in the tubers. Spraying with insecticides every 7

days did not provide an adequate control. An attack of *Rhizoctonia solani* also affected about 20% of the plants.

At San Ramon, the two major problems were *Rhizoctonia solani*, which attacked about 50% of the plants, and late blight, *Phytophthora infestans*. The damage of late blight was relatively well controlled by fungicides.

At Yurimaguas, a heavy attack of leaf hoppers (*Empoasca* spp.) was recorded and isolated plants were affected by *Pseudomonas solanacearum*. The major disease problem was *Botrytis* sp. which affected the plants at an early stage of growth and killed many of them. Differences in susceptibility were noticeable. Foliage of the most severely affected individuals was practically covered by the mycelium of the fungus. It is interesting to note that no attack whatsoever of late blight was detected during the growing period. The reason could be that the high temperature limits the survival of the fungus. Later experiments were also free from attack by *P. infestans*.

### Genotypes

A variety of germ plasm combinations was tried in these experiments to gain insight into their relative abilities to withstand environments. Simmonds (1971) indicated that some main crop or late maturing temperate potatoes can do remarkably well in the subtropics and tropics at medium altitudes. The data in Table 1 support his statement. In fact, the three *tuberosum* cultivars at San Ramon and La Molina yielded significantly better than the Peruvian cultivars used as checks. The failure of the local cultivars was expected because they were all selected under highland conditions (short-day and cool temperatures). On the other hand, *tuberosum* cultivars normally short day types (Mendoza 1974) have a higher critical daylength than Andean potatoes. Also, their adaptation to higher temperatures is a consequence of the conditions under which they were selected in the summers of the northern hemisphere. However, this relative tolerance to higher temperatures appears to be limited and the conditions present at Yurimaguas seemed to be beyond the threshold of adaptation for them.

The NT × NT hybrids at San Ramon and Yurimaguas had a similar behaviour to the T × T cultivars, but at La Molina they were slightly inferior. This would indicate that the

selection work made by some northern hemisphere breeding programs for adaptation of *andigenum* to longer and warmer days has made measurable progress (Plaisted et al. 1975). For further selection for adaptation to lowland tropics, the *neo-tuberosum* material may be more responsive than *tuberosum* because it has a broader genetic base (Mendoza and Haynes 1974a).

The performance of some of the "wider" hybrids, T × NT and T × P is encouraging because it shows that the existing potential for adaptation to the lowland tropics might be capitalized upon under a carefully designed breeding scheme. Some clones under the severe environmental conditions of Yurimaguas yielded about 0.5 kg/plant in 60 days. This yield is approximately equivalent to 15 t/ha, which for a short growing period constitutes a remarkable performance. Some of the same hybrid clones also performed very well, in relation to the rest of the materials tested, in the other two locations.

The most promising materials for the lowland tropics, at least at present, have as one parent a *tuberosum* cultivar that provides earliness and relative heat tolerance. To obtain highly heterotic hybrids a *neo-tuberosum* or a *phureja-stenotomum* hybrid that produces 2n gametes by first division restitution (Mok and Peloquin 1975) would be suitable as the other parent. To realize the maximum gain from each source of germ plasm, it would be necessary to perform some previous selection for adaptation to tropical conditions (Mendoza and Haynes 1974b). In addition to the widening of the genetic diversity obtained by such combinations of germ plasm, also an adequate level of resistance to diseases must be achieved.

Early maturity is an essential requirement for tropical adaptation. However, this earliness does not necessarily need to be in the absolute sense of time from planting to senescence. A medium maturity cultivar with an early tuber initiation and fast bulking may also be suitable even if the vines do not reach maturity rapidly. A great deal of genetic variability for tuber initiation has been found (Mendoza 1974) and this trait may be rapidly improved under selection. The earliness obtained by genetic means may be increased to some extent using some preconditioning of tubers before planting. Presprouting of tubers and a proper physiological age may help to hasten the crop (Madec and Perennec 1962).

There are some additional problems such as disease resistance, mainly to bacterial wilt and late blight, that have to be solved by breeding to make the potato an economically competitive crop. The impact of introducing the potato to these new areas of cultivation could be tremendous since the high nutritive value of this crop is well known.

- Madec, P., and Perennec, P. *Les relations entre l'induction de la tubérisation et la croissance chez la plante de la pomme de terre (Solanum tuberosum L.)*. Ann. Physiol. Veg. 4, 1962, 5-84.
- Mendoza, H. A. *Genetics of photoperiodic behaviour in tuber-bearing Solanum*. Ph.D. thesis, North Carolina State University, Raleigh, N.C., USA, 1974.

Mendoza, H. A., and Haynes, F. L. *Genetic relationship among potato cultivars grown in the United States*. Hort. Science, 9(4), 1974a, 328-330.

*Genetic basis of heterosis for yield in the autotetraploid potato*. Theoretical and Applied Genetics, 45, 1974b, 21-25.

Mok, D. W. S., and Peloquin, S. J. *Breeding value of 2n pollen (diplandroids) in tetraploid  $\times$  diploid crosses in potatoes*. Theoretical and Applied Genetics, 46, 1975, 307-314.

Plaisted, R. L. et al. *Five cycles of selection within a population of S. tuberosum, spp. andigena (Abstr)*. Am. Potato J. 52, 1975, 280.

Simmonds, N. W. *The potential of potatoes in the tropics*. Tropical Agriculture, 48, 1971, 291-299.

# Sweet Potato Breeding Using Wild Related Species

Masashi Kobayashi and Tsukasa Miyazaki<sup>1</sup>

A sweet potato variety and various breeding materials that include germ plasm of wild *Ipomoea* suggest that the wild species have much to offer sweet potato breeders. The wild relatives that can be crossed with cultivated sweet potato include diploids, triploids, tetraploids, and hexaploids. All of them resemble the sweet potato in two respects: they have similar floral morphologies and incompatibility systems. These characters may be useful in future searches for wild plants.

Our experience in the practical use of wild species in sweet potato breeding, a flower induction technique, self- and cross-compatibility test, and species hybridization with sweet potato suggests that useful genes can be expected from wild species. Some principles necessary for an effective gene introduction system have been identified.

The improvement of yield and quality proceeds quite rapidly during the initial phase of plant breeding; however, additional genetic gains become increasingly difficult to attain. This is especially true if the gene pools are limited and breeding procedures remain unchanged. Sweet potato breeding in Japan reached this stage. About 95% of the total area planted in sweet potato were local varieties in 1940, but over 80% were replaced in the next 10 years by improved varieties bred through a systematic breeding program. This replacement of the local varieties with improved varieties indicates that the breeding efficacy in the initial phase was considerably higher. The gene sources that were used were mainly popular local varieties. The second im-

provement resulted from the development of "Koganesengan" in 1966, which included exotic breeding materials introduced from the USA after 1956. Introduced varieties had performed an important role in the genetic progress that had been made prior to this, especially increasing the yield of tuberous roots and the starch content beyond the plateau achieved by domestic materials. Another plateau developed, however, and it seemed impossible to develop new varieties exceeding the yield level of "Koganesengan." A third increase in yield levels was marked by the development of "Minamiyutaka" in 1975. This variety, with one eighth of its germ plasm from the wild plant K123, topped the yield levels achieved by "Koganesengan" and other cultivars at several locations.

In 1955, many wild plants related to sweet potato were collected by Nishiyama in Mexico and the United States (Nishiyama 1959). This

---

<sup>1</sup>Kyushu National Agricultural Experiment Station, 1340, Jitcho, Ibusuki, Kagoshima, 891-04, Japan.

collection was used to study sweet potato phylogeny and the utilization of wild plants in sweet potato breeding. Progress in both fields accelerated and additional collections increased the number of wild plants that were available.

Nishiyama et al. (1975) reviewed phylogenetic studies, and Sakamoto (1970) summarized studies using wild relatives before 1970. These wild species appear to have much to offer sweet potato breeders, and the present paper is an attempt to demonstrate a practical method for using these relatives in breeding.

### Species Crossed with Cultivated Sweet Potatoes

More than 200 accessions of *Ipomoea* species have been introduced from Mexico and other countries in Central America and the northern part of South America by several researchers since 1956. Our interest was directed toward wild plants that could be hybridized with the sweet potato directly or indirectly. So little research had been done from a breeding viewpoint on *Ipomoea*, that we did not know which species could be crossed with cultivated sweet potatoes. In addition, species identification was almost impossible because species of the section *Batatas* had not been well defined taxonomically. (Hopefully, reclassification of *Ipomoea* will be done soon.)

After hundreds of crosses between wild relatives and sweet potatoes, we concluded that *Ipomoea* species that can be hybridized with sweet potatoes have the following characters: (1) the flower is similar to that of sweet potato; the corolla is bell-shaped and not funnel-form, the colour of the interior of the tube is invariably darker than that of the limb, and the glands at the base of the corolla are prominent; and (2) the plants are self-incompatible, and there are several incompatibility groups among them. We could find no common characteristics other than these two. These characters may be useful when collectors search for wild plants for sweet potato improvement.

Wild *Ipomoea* that showed the above characteristics and could be crossed with cultivated sweet potatoes were as follows:

K221: Ten seeds of this plant were collected at Acapulco, Mexico by M. Kobayashi, Kagoshima Agricultural Experiment Station, in 1960. This diploid ( $2n = 30$ ) plant was called

*I. leucantha* Jacq. by Teramura (Teramura et al. 1967). For a long time, we believed that K221 would not hybridize with sweet potato without bridge plants, but in 1975 we obtained many seeds between K221 and sweet potato. It was also found that the autotetraploid of K221 induced by using colchicine crossed well with sweet potatoes.

K222: This accession was collected together with K221 by M. Kobayashi. All eight plants of this accession were found to be triploid ( $2n = 3X = 45$ ) by S. Shiotani, Mie University (Teramura et al. 1967). Teramura's tentative identification was *Ipomoea (trifida 3X)*.

K233: The seeds of this accession were collected at Veracruz, Mexico, by M. Muramatsu, Okayama University, in 1962. This tetraploid ( $2n = 4X = 60$ ) has been called *I. littoralis* Blume by Teramura, but K233 is the same plant that Jones called *I. gracilis* R. Br. (Jones 1970; Martin and Jones 1972).

K300: The seeds of this accession were supplied in 1972 by F. W. Martin, USDA, Mayaguez, Puerto Rico. According to him this tetraploid ( $2n = 4X = 60$ ) species occurs in Ecuador and Colombia. This plant could be hybridized with sweet potatoes only when K300 was used as the male parent.

K400: This collection was made in Mexico by S. Shiotani, Mie University, in 1973. The plants are self-incompatible and there are several incompatibility groups among them. Whether this plant will cross with sweet potatoes is not yet certain, but we expect that it will hybridize with sweet potato directly. K400 is a tetraploid ( $2n = 4X = 60$ ).

K123: This accession was collected in Fortin, Mexico by Nishiyama in 1955 and was designated *I. trifida* (H.B.K.) G. Don. K123 is hexaploid ( $2n = 6X = 90$ ) and has been considered as the direct progenitor of sweet potato by Nishiyama (Nishiyama 1961; Nishiyama et al. 1975). Some researchers, however, consider K123 to be a wild form of sweet potato rather than a different species (Jones 1967; Martin and Jones 1972; Yen 1973).

Apart from the species nomenclature, K123 has been recognized to be very important as a gene source for sweet potato improvement. It was used in the development of the registered variety "Minamiyutaka," which has high yield and high resistance to some diseases and insects. Many strains with K123 germ plasm are being used in our breeding program.

Table 1. Effect of grafting on flowering of wild plant, K300 (1974) planted on 7 July and grafted on 5 September.

Plant	Natural condition		Grafted on morning glory	
	Date first flowers opened	Number of flowers <sup>a</sup>	Date first flowers opened	Number of flowers <sup>a</sup>
K300-1	1 Nov	215	11 Oct	750
K300-2	3 Dec	32	11 Oct	432
K300-3	15 Oct	53	20 Oct	312
K300-4	—	0	26 Oct	303
K300-5	10 Dec	13	20 Oct	565
K300-6	—	0	13 Oct	331
K300-7	8 Nov	47	11 Oct	364

<sup>a</sup>Counting started when the first flowers opened and ended 31 Dec 1974, while the flowering continued.

### Flower Induction Technique

Under natural conditions flowering of the wild relatives available for sweet potato breeding is generally encouraged by short days. Most flower in October or November whether they are planted as seeds or vines in April through July.

An effective means of inducing flowering in these materials would greatly facilitate the utilization of the wild plants for sweet potato breeding. An effective technique for inducing flowering in these plants was found in our laboratory. During any season, plants treated with this technique begin to flower within one month, even under long day conditions. The flower induction procedure consists of the following steps: (1) Treat seeds of the dwarf type morning glory, *I. nil* (L.) Roth cv. Kidachiasagao, with sulfuric acid for 1 hour, rinse with water overnight, and then plant in 15 cm pots; (2) After germination, keep the pots under all-day lighting conditions for about 1 month; (3) When seedlings are about 40 cm high and have 8–10 leaves, cut off the stem tips and split the stem for insertion of the scion. The stem of the wild plants used as scions should be about 20 cm long and have cuts 5–8 cm long on both sides of the stem; (4) Hold the grafts in place with grafting clips until the scion is established, and keep the grafted plants in a humid and sheltered place for about 1 week; and (5) Transplant the grafted plants to 24-cm pots and place under favourable growing conditions. The effectiveness of this procedure is indicated by Table 1.

### Self- and Cross-Incompatibility

The wild *Ipomoea* that would hybridize with the sweet potato were all self-incompatible and several intra-incompatible, inter-compatible groups were recognized. Self- and cross-incompatibilities of the wild relatives were determined using the following staining technique.

Crosses were made under greenhouse conditions. Flowers pollinated before 10:00 with pollen from appropriate plants were collected 3 or more hours after pollination. Stigmas, with styles attached, were placed on glass slides and stained with 0.5% cotton blue in lactol phenol. A cover-glass was placed on the stigma and pressed. The prepared slides were kept at room temperature for microscopic observation the following day. Usually five flowers per cross were used for this purpose. This schedule generally gave satisfactory results (Table 2). Compatibilities of the wild relatives and sweet potato are presented in Table 3.

No new principles have been used, but we believe that this technique will be useful for research workers interested in the utilization of wild *Ipomoea* for sweet potato improvement.

### Hybridization Results

Pollen reaction on the stigma suggests whether two plants will cross. In most cases involving the wild species and the sweet potato, however, we did not obtain seeds even when the pollen germinated on the stigma. Therefore, it is necessary to check whether seeds can be produced by actual hybridization. For this pur-



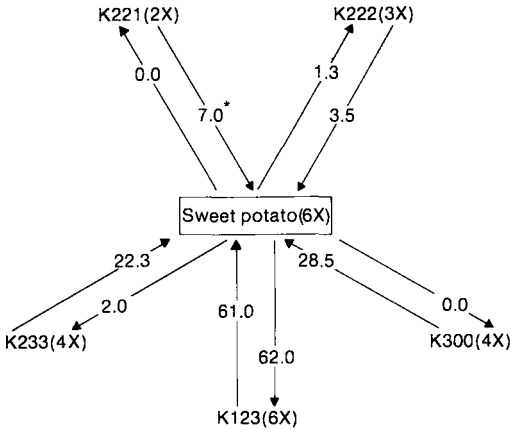

Fig. 1. Maximum seed set (%), from figures obtained between 1958 and 1975, in crossing of wild species and sweet potatoes. Arrows point from male to female in crosses. Asterisk indicates that female was Kyushu 58, which includes one fourth germ plasm of K123.

### Direct Use of Wild Plants

Plants with 90 chromosomes like K123 can be used directly as a donor in crossing procedures.  $F_1$ 's must be back crossed to sweet potato cultivar(s) at least two times. "Minamiyutaka" was bred by this method. Some  $F_1$ 's between K222 ( $2n = 45$ ) and sweet potato ( $2n = 90$ ) were found to be hexaploids ( $2n = 90$ ). Thus, it is possible to obtain  $F_1$ 's with 90 chromosomes from crosses with wild relatives even when they are diploids or tetraploids. Therefore, we can use wild plants directly, although seed set percentages are extremely low in some cases.

### Use of Synthesized Hexaploids

Some theoretical ways of synthesizing hexaploids ( $2n = 90$ ), some of which we have actually used for sweet potato improvement, are:

- (1) Diploid  $\leftrightarrow$  Tetraploid, Tetraploid  $\times$  Diploid  $\leftrightarrow$  Hexaploid
- (2) Tetraploid  $\leftrightarrow$  Octaploid  $\times$  Tetraploid  $\rightarrow$  Hexaploid
- (3) Diploid  $\times$  Tetraploid  $\leftrightarrow$  Hexaploid
- (4) Triploid  $\times$  Triploid  $\rightarrow$  Hexaploid (in the case of outcrossing of K222)
  - $\leftrightarrow$  : Doubled chromosome using colchicine solutions.
  - $\rightarrow$  : Doubled chromosome by natural unreduced gametes.

In our crossing experiments, seed set percentages from crosses between wild plants and

sweet potatoes were higher when the synthesized hexaploids were used as female parents.

### Use of Heteroploidy

Because the sweet potato or hybrids with it can be propagated vegetatively, it is practical to use heteroploids with desirable agronomic characteristics. It is also possible to back cross heteroploids with the sweet potatoes to obtain other heteroploids possibly having more desirable characteristics. The problem with heteroploidy is that seed set percentages from back crossing are extremely low.

### Use of Lower Ploidy

Tetraploids with some economical characteristics are being bred in our laboratory using K221, K222, and cultivated sweet potatoes. We have obtained tetraploids with enlarged storage roots. Thus, it seems quite possible to develop tetraploid sweet potatoes. By taking advantage of the wild relatives of the sweet potato it may also be possible to develop diploids producing tuberous roots like hexaploid sweet potatoes.

The authors wish to express their sincere thanks to Dr Alfred Jones, Research Geneticist of ARS, USDA, for his kindness in reviewing and correcting the manuscript.

Jones, A. *Should Nishiyama's K123 (Ipomoea trifida) be designated I. batatas?* Econ. Bot. 21, 1967, 163-166.

*Asynapsis in Ipomoea gracilis R.* British J. Heredity, 61, 1970, 151-152.

Martin, F. W., and Jones, A. *The species of Ipomoea closely related to the sweet potato.* Econ. Bot. 26, 1972, 201-215.

Nishiyama, I. *Collecting the sweet potato and its allied species in U.S.A. and Mexico.* Japan J. Breeding, 9, 1959, 73-78.

*The origin of the sweet potato plant.* In Tenth Pacific Sci. Congr., Univ. Hawaii, Honolulu, 119-128, 1961.

Nishiyama, I., Miyazaki, T., and Sakamoto, S. *Evolutionary autopolyploidy in the sweet potato (Ipomoea batatas (L.) Lam.) and its progenitors.* Euphytica, 24(1), 1975, 197-208.

Sakamoto, S. *Utilization of related species on breeding of sweet potato in Japan.* Japan Agr. Res. Quarterly, 5(4), 1970, 1-4.

Teramura, T., Shiotani, I., and Kawase, T. *Triploid plants of Ipomoea collected in Mexico.* Japan J. Breeding (Indep. Vol. 2), 1967, 422-423.

Yen, D. E. *Construction of the hypothesis for distribution of the sweet potato.* In Man across the sea. Univ. Texas Press, Austin, Texas, 328-342, 1973.

## Vegetative and Sexual Management in Food Yam Improvement

L. Degras<sup>1</sup>

Yam models are described, giving several required characteristics for clonal cultivation of *Dioscorea alata*, *D. cayenensis*, and *D. trifida*. Intraclonal selection is possible because of tuber internal heterogeneity, clonal population diversity, and time dispersed production and germination of individual plant bulbil. A kind of "somatic drift" is observed.

Several aspects of determinism of tuberization and flowering are cited, and day/night ratio, light intensity, soil mineral balance, internal vegetative phases, and genetic factors are recognized in flowering and in sex-ratio determinism.

Basic management using axillary structure growth-substance treatment for vegetative, tuberization, flowering, and sex control is discussed. In addition, the genetic analysis of characteristics, and different cultivation systems are examined.

Yam improvement has normally been based on the introduction of clonal cultivars selected from traditional populations. Use of the sexual system for food yams has been attempted; however, it is among pharmaceutical yams that the sexual system has been extensively used and studied.

Improvement of the food yam through its sexual system began in 1966 with *D. trifida* in Guadeloupe (Degras 1969), and it is now spreading through an inter-Caribbean selection on behalf of the ISTRC-CFCS yam study group. The largest food yam breeding potential now comes from IITA where, since 1970, Sadik and Okereke (1975) have developed the sexual utilization of *D. cayenensis* ssp. *rotundata*, and tested a large amount of seeds throughout the tropics.

This does not, however, mean that clonal selection should be stopped, rather it still may have an important role to play.

### Yam Models in Current Clonal Cultivation

At the present time, all cultivated yams are clonally propagated. The characteristics of *D. alata*, *D. cayenensis*, and *D. trifida* in the French West Indies are as follows: *D. alata* — (1) high cooking quality (white flesh), (2) long storage without loss of weight, (3) resistant to anthracnosis and viruses, (4) resistant to water stress, (5) high yield with medium and regular size tubers (other characteristics

existing widely in the species are: good dormancy, resistance to *Penicillium oxalicum*, germination in dry conditions, and good yield without staking); *D. cayenensis* ssp. *rotundata* — (1) fair tuber maturity long before foliage decay, (2) good tuber regrowth after commercial harvest, (3) high cooking quality (whitish flesh), (4) year-round tuber development, (5) medium storage duration of commercial harvest, (6) prickless roots, (7) high early yield; *D. trifida* — (1) tubers available year-round because of: (a) fresh production all season, (b) food storage duration, (2) high cooking quality with sweet taste, (3) tuber grouping near soil surface, (4) high yield with 10% seed sized tubers, (5) resistant to viruses, *Penicillium oxalicum*, nematodes, and mealy bugs, (6) spheroidal tuber shape, (7) resistant or tolerant to drought.

### Intraclonal Selection

Variation within a clone exists. Heads, middles, and tails from the same tuber differ in earliness of germination, yield, and number of stems or tubers produced. In addition, normal bud regulation is suppressed when the slice size is greater than 5 g (Degras and Mathurin 1975). It is important that differences have been repeated over first and second generations of two *D. trifida* clones obtained from different parts of a tuber of cultivar INRA 25: flowering time differences at the second generation were in accordance with behaviour in the first generation, differences in time to maturity were up to 1 month.

We do not know the level of genetic homogeneity of traditional cultivars, but some may include mutational variations. Off-types are

<sup>1</sup>Plant Breeder, Institut national de la recherche agronomique (INRA), Centre des Antilles et de la Guyane, Domaine Duclos, Prise d'eau, Petit Bourg, France.

Table 1. Agronomic variability from *D. cayenensis* cultivar Krenglé intraclonal tuber selection.

Tuber shape (seed tuber)	Plant size (200 days)	Growth duration <sup>a</sup>	Yield <sup>b</sup>	Tubers harvested <sup>b</sup>	Mean tuber weight <sup>b</sup>
Cylindrical <sup>c</sup>	100	100	100	100	100
Cylindro-conical	110	111	91	103	89
Conical	100	104	88	108	82
Ovoidal	113	104	82	88	94
Spheroidal	103	100	73	102	67

<sup>a</sup>Statistical significance has been found for shape  $\times$  seed tuber weight interaction in cycle duration.

<sup>b</sup>Significative differences  $p = 0.05$ .

<sup>c</sup>Cylindrical data are taken as basis = 100 for each trait.

normally easily recognizable when cultivated with cultivars: cultivar individuality is a fact. Nevertheless, in the well known cultivar *D. cayenensis* ssp. *rotundata* "Krenglé," in central Ivory Coast, a number of tuber forms could be separated. When cultivated separately they have distinct performances (Table 1).

Another case of intraclonal variation that may be explored arises from different times to maturation of the bulbils of the plant. In *D. bulbifera* and *D. alata*, the difference may reach 1 month.

These examples show that a form of "somatic drift" of clonal expression of a yam genotype could proceed from conscious successive selection of extreme phenotypic variations. It is obvious that in current cultivation, such variations do not cause marked changes of the clonal population. But we think that through controlled cultivation (planting time and density) and controlled dormancy duration we could expect to alter the phenotypic balance of clonal properties. The selection of the type of planting material from tubers of a clone could at the same time determine the best rate of multiplication and the highest rate of phenotypic variation that could be explored through environment  $\times$  growing condition interactions (Mathurin and Degras 1974, Degras and Mathurin 1975). In this respect, an experiment is now in progress using *D. trifida* cultivar INRA 25.

## Flowering Determinism

### Flowering Stage and Vegetative Development Relation

Wild and domestic yams seem to give preference to the vegetative system over the sexual system (Burkill 1960). In many cases

the sexual phase is very depressed in annual cultivation. A kind of competition exists between vegetative accumulation and sexual development for the following reasons.

Tuberization and flowering seem to be favoured by short days for a number of species. This has been shown for bulbils and for tuber growth. *D. alata* and *D. trifida* normally flower in the autumn, but Henry (1967) obtained earlier flowering for a number of seedlings under short days.

High light intensity is necessary for flowering and tuberization: Henry (1967) observed a lower level of flowering of *D. trifida* seedlings when shaded. For most species, staking, which permits more light to enter the canopy, gives higher tuber yields. The difference is striking for a number of dry-forest climax species like *D. cayenensis*, whereas it is less important for rain-forest climax species like *D. alata* and *D. trifida*.

The physiological response to fertilization suggests a common process for initiation of tuberization and flowering. We observed that given balances of NPK in *D. cayenensis* increased the tuber yield and the percentage of plants that flower. In *D. alata*, stem fasciations, which may be considered in some cultivars from central Ivory Coast as a substitute for flowering, occurred when tuber yields were greatest.

Generally speaking, flowering seems to be triggered by a certain level of development of the vegetative organs. This could account for the low level of flowering observed in the first growing cycle of *D. trifida* seedlings when compared to the second cycle. This level is not merely a matter of biomass: plants with heavy vegetative organs do not necessarily flower. It seems that the relation is both qualitative and quantitative.

Aspects of the control of the vegetative and flowering stages are also seen in the balance between bulbil and inflorescence development in some species. Along one plant of *D. bulbifera* (Martin 1974) there are a succession of foliar axils, first with bulbils alone, then with both bulbils and inflorescences, then with inflorescences alone. Among populations of primitive cultivars of *D. alata* some clones bear only bulbils and others only inflorescences. Bulbil setting begins somewhat before the flowering time.

Genetic factors also control flowering formation. Apart from the wide differences known between cultivars in a *D. cayenensis* for instance, it is known that sexual reproduction and selection can increase the percentage of flowering (Sadik and Okereke 1975).

So, ecological factors like day/night ratio, light intensity, soil mineral balance, internal vegetative phases, and genetic makeup control yam flowering.

### Sex-Ratio Determinism

Though dioecism is the general case in yams, a number of cases have been observed where some level of monoecism and even of hermaphroditism is obvious. In central Ivory Coast the occurrence of monoecious plants in *D. cayenensis* is affected by mineral fertilization and season, and its occurrence is higher in sexual progenies than in clonal material. Sadik and Okereke (1975) have recently confirmed these findings.

In a number of species a prevalence of male flowers is reported. In some wild species, the female form is unknown, for example in Madagascan flora (Burkill et al. 1950) or in Mexican flora (Matuda 1954). Martin (1966) who studied the behaviour of steroid species, suggested that the variations of sex-ratio in progenies proceed from the different heterosomic status of the male parents, which in tetraploid species could be XXXY, XXYY, or YYYY. The latter is lethal or only gives males.

In *D. trifida*, Henry (1967) observed a high prevalence of males in common clonal propagation, a lower prevalence in the first seedling growth cycle, and a still lower prevalence in clonal multiplication of these seedlings. Degras et al. (1973) observed an increase of female plants when flowering was increased. In *D. trifida* seedlings a 3/1 male/female ratio, which in the case of predominant tetraploidy, could result from a XXYY male. In *D. cay-*

*ensis* spp. *rotundata*, Sadik and Okereke (1975) observed no female inflorescence in the first seedling cycle, but in the following growth cycle, female plants appeared in a higher proportion than in traditionally vegetatively reproduced populations.

Another aspect of *Dioscorea* flowering seems constant: the time of female flowering with respect to that of males. This may be associated with the tendency toward higher tuber yields from female plants.

To obtain high levels of yam crossing the following are recommended: (1) a high level of vegetative growth, which is necessary for full female expression; (2) several plantations of both parents for simultaneous flowering; and (3) common staking of male and female inflorescences so that flowers are close (pollen is sticky and wind dispersal poor).

New research could lead to a better management of yam flowering. The very specific nature of the nodal and axillary yam structure is obvious from the special vascular organization (glomeruli) ascribed to this genus (Ayensu 1972). These glomeruli are capable of developing into flowers, bulbils, or chiotics. A systematic screening of growth substance, and the nutritional and physical effects on the yam nodal axillary system, as applied to the axillary complex of *Euphorbiaceae* (Champault 1973), may be successful in increasing flowering.

### First Data from Genetic Analyses

Martin (1966) attempted an interpretation of sex-ratio heredity in yam, and we have limited data on *D. trifida* (Degras 1969, Degras et al. 1973). We now have more complete data for a number of crosses in this species.

### Anthocyan in Tuber Flesh

Table 2 gives the distribution of anthocyan in progeny. Interpretation is difficult because of: the limited seed germination; the death of a number of plants in the field; and the possible interaction of anthocyan expression with degree of maturity of harvested seedlings. Nevertheless we observed: (1) a dominance of purple over white; (2) a transgression beyond the purple; and (3) an occurrence of intermediate levels; suggesting a number of modifying factors.

### Length of Nontuberous Parts of Stolon

The length distribution of the stolons, for 40 progeny of *D. trifida* (C.C.V. × INRA), was

Table 2. Distribution of anthocyan in tubers of 40 progeny of *D. trifida* (C.C.V. × INRA).

Flesh colours	Skin colours			
	Deep purple	Purple	Light purple	White
Deep purple	3.3	1.6	—	—
Purple	—	22.9	18.0 <sup>a</sup>	—
Light purple	—	3.3	18.0	—
Very light purple	—	1.6	3.3	—
White	—	1.6	6.6	19.6 <sup>b</sup>

<sup>a</sup>C.C. Violette type.

<sup>b</sup>INRA 40 type.

as follows: less than 10 cm 32.2%; 10–15 cm 26.2%; 15–20 cm 20.8%; and more than 20 cm 20.8%. Long stolons appear dominant over short ones. Here also a transgression beyond parent limits is observed. It seems that for most characteristics, in accordance with the general high level of polyploidy in cultivated yams, multiple level factor determinism is the rule.

The analysis of yam genetics will benefit from the utilization of autofertile monoic or hermaphroditic plants. If androgenesis could be applied to yam pollen to give haploid clones, this would open new opportunities of genetic analysis. Recently attempts have been successful (Arnolin 1976, personal communication).

### Sexual Progeny Selection

The success of selection from free and controlled pollinated crossings of *D. cayenensis* in West Africa, and *D. trifida* in the West Indies, shows that theoretical knowledge of the genetic mechanisms are not needed to make advances.

The first conscious agronomic utilization of hybridization in *D. cayenensis* occurred in 1955 at Bouaké (Ivory Coast) where Franck harvested 3020 seeds from cultivar "Assaoua" and obtained 48 seedlings. Only 13 clones were retained. We studied them from 1956–58, and selected from them Assaoua B9 (Van de Venne 1973, personal communication).

Among many selection criteria we noticed, at the first clonal cycle, the value of flowering, sex expression, and phyllotaxy. Nonflowering plants produced 668 g, monoic 770 g, and female 1135 g (mean tuber weight). Leaf and branch balance on successive nodes gave a yield of 1000 g (worst balanced system) to 3000 g (best balanced systems). A relation between

sex type and yield has also been found by Sadik and Okereke (1975).

Seed germination and many aspects of the two first progeny growing cycles of *D. trifida* were studied by Henry (1967). Since 1965 in Guadeloupe, about 5000 seedlings from 20 crosses have been observed and tested, and improved cultivars have been obtained. Among them INRA 25 and INRA 5-20 associate a number of the required characteristics. Resistance to diseases (*Penicillium* rot, viruses) and pests (mealy bugs, nematodes) are still lacking in our hybrids. Special genetic searches are projected in the Guyanas.

### New Horizons

Now that the feasibility of genetic improvement of yams is well established, we can examine some new cultivation systems.

First, more intensive cropping will proceed from the following genetic modifications: (1) greater efficiency in translocation of assimilates to the tuber, including limitation of stem development, shortening of the prebulking tuber phase, and faster tuber maturation; (2) lower interplant competition, permitting higher plantation density; (3) more rapid drying of the tops at maturity to aid mechanical harvesting; (4) underground structure superficially compacted for better mechanical harvesting; and (5) higher nutritive value of tuber. Known variability permits a reasonable expectation of obtaining clones with most of these traits.

Other quite new genetic modifications can be envisaged if sexual seeds become the basic material for plantations. Preliminary requirements are: highly prolific female parents; good seed germination; and knowledge of the combining ability of the parents.

Two levels of these crop modifications can be projected: (1) the tubers from the seedling may be used as propagating material for commercial production; and (2) the seedling cycle must give good tuber yields and hence breeding selection will change from clonal to seedling performance. In both cases a relative genetic homogeneity is wanted in the progeny. Both parents, or at least one of them, should be built through successive brother × sister crossings in order to reach some level of homozygosity for main characteristics.

Ayensu, E. S. *Anatomy of the monocotyledons. VI. Dioscoreales*. Metcalfe, C. R. (ed.), Clarendon Press, Oxford, 1972, 182 p.

- Burkill, I. H. *The organography and the evolution of Dioscoreace, the family of the yams*. J. Linn. Soc. Bot. 56, 1960, 319-412.
- Burkill, I. H., and Perrier de la Bathie, H. *Dioscoreacées (Dioscoreaceae). Flore de Madagascar et des Comores, 44e famille*. Firmin-Didot, Paris, 1950, 73 p.
- Champault, A. *Effets de quelques régulateurs de la croissance sur des noeuds isolés de Mercurialis annua L. (2n = 16) cultivés in vitro*. Bull. Soc. Bot. Fr. 120, 1973, 87-100.
- Degras, L. *Quelques données sur la variabilité des descendances d'Ignome Cousse-couche (D. trifida)*. Proc. VIIth Ann. Meet. Carib. Food Crops Soc., Guadeloupe-Martinique, 1969, 59-65.
- Degras, L., Arnolin, R., and Poitout, R. *Sélection de l'Ignome Cousse-couche (Dioscorea trifida L.)*. Proc. 2nd Int. Symp. Trop. Root Crops, Soc., Ibandan, Nigeria, 1973 (in press).
- Degras, L., and Mathurin, P. *New results in yam multiplication*. Proc. 13th Ann. Meet. Carib. Food Crops Soc., Trinidad, 1975.
- Henry, V. C. R. *Studies on botanical and agronomic characteristics in cush-cush (Dioscorea trifida L.)*. Thesis, McGill Univ., Montreal, Canada, 1967.
- Martin, F. W. *Sex ratio and sex determination in Dioscorea*. Heredity, 57(3), 1966, 95-99.
- Mathurin, P., and Degras, L. *Effects of division levels of seed tubers on yams (D. alata, D. trifida) germination and yield*. Proc. 12th Ann. Meet. Carib. Food Crops Soc., Jamaica, 1974.
- Matuda, E. *Las Dioscoreas de Mexico*. Ann. Inst. Biol. Univ. Mex. 24, 1954, 279-390.
- Sadik, S., and Okereke, O. U. *A new approach to improvement of yam Dioscorea rotundata*. Nature, 254, 1975, 134-135.

# Sweet Potato Clones Adapted for Libyan Agriculture

Warid A. Warid, Boleid W. Dahmani, and Mosbah M. Kushad<sup>1</sup>

Five experiments were conducted from 1971 to 1973, on the adaptability of some introduced clones of sweet potato. An average yield of marketable enlarged roots of 7.4–21.2 t/ha was produced by clone American from USA, 24.3–26.6 t/ha by clone Kahera Hybrid, and 14.5–29.6 t/ha by clone Mabrooka. The last two clones were introduced from Egypt.

The most variable clone in weight of vine, number of roots, or yield was Mabrooka, and the least variable was Kahera Hybrid. Within a given clone, the yield showed the highest degree of variability. A nonsignificant correlation existed between vine weight and number of roots. A positive correlation was found between vine weight and yield in two clones, and between number of roots and yield in all clones.

The sweet potato has always been an important food crop. However, the sweet potato crop is not popular among Libyan farmers. The enlarged roots offered for sale are of inferior quality. They are elongated and not uniform in shape. The skin surface is ridged and tan coloured. The flesh is whitish, almost tasteless when boiled, and has a high fibre content. The vegetable breeding program at the University of Tripoli has included the improvement of this crop since 1969. A few enlarged roots of some clones bred in Egypt, Japan, and the United States were introduced and asexually propagated for the first 2 years. Some of these clones were discarded early because of poor growth of vines, low yield of enlarged roots, or the production of only thick and non-

marketable roots. Perennial plots were established for promising clones to obtain stem cuttings for use as planting material in clonal evaluation tests.

Little work has been done on sweet potatoes in Libya, although recommended cultivars were reported by Mazzocchi and Thrower (1962). The aim of this study was to screen introduced clones, and possibly recommend one or more clones for food and industry.

## Materials and Methods

A total of five experiments were conducted from 1971 to 1973 at the University of Tripoli. The soil was a sandy loam (pH 7.5–8.5). Stem cuttings, 20–25 cm long, were planted 30 cm apart in rows 60 cm wide. The experimental plot unit varied from 2 to 8 m<sup>2</sup> (excluding guard rows). The crop was grown as a summer crop under irrigation. Mean air temperature

---

<sup>1</sup>Department of Plant Production, College of Agriculture, University of Tripoli, Tripoli, Libya.

had a minimum range of 13–22 °C and a maximum range of 23–32 °C. The fertilizer (NPK, 60, 120, 120 kg/ha) was applied 2–3 weeks after planting, and 1 month later as a side dressing.

### Clonal Productivity

Four clones, namely, Yabany from Japan, America from the U.S., and Kahera Hybrid and Mabrooka from Egypt were tested in a randomized block design. The test in 1971 was conducted at Green Hill Project (recently reclaimed land) using six replications. Planting was on 7 June 1971 and harvesting (43 284 plants/ha) occurred 37 weeks later. In 1972, planting was done on 16 May 1972 and after 31 weeks 47 667 plants/ha were harvested. In 1973, the planting was conducted on 21 May 1973, harvesting 31 weeks later yielded 50 500 plants/ha. Four replications were used in both 1972 and 1973. The vines at harvest were cut close to the soil surface. Enlarged roots of marketable size, with a minimum diameter of 3 cm, were weighed. Analysis of variance was applied to the data, and coefficients of variation were computed for each characteristic.

### Effect of Planting Date and Harvesting Period

This test was conducted in 1972. It included two clones (Mabrooka and Yabany), three planting dates (18 May, 1 June, and 15 June), and two harvesting periods (after 26 and 30 weeks). A split plot design was followed using three replications. The number and weight of enlarged roots were recorded.

### Determination of Dry Matter

Samples of enlarged roots produced in the 1973 test were used to determine the dry matter content of three clones (American, Kahera Hybrid, and Mabrooka). A sample was drawn from each root by a piercing tool that punctured the root transversely in the middle and near both ends. Four replicated samples, each having a fresh weight of 30–35 g, represented a given clone. They were dried to constant weight at 90 °C in an oven for several days. The dry matter content was the dry weight calculated as a percentage of the original weight of the portion used. The test was repeated 20 days later. Cooked and baked roots of the tested clones were described for flesh colour, texture, and general acceptability.

### Correlation Between Characters

American, Kahera Hybrid, and Mabrooka clones tested in 1973 were harvested after 27 weeks. A 30-plant sample for each clone was used. Three characteristics: fresh weight of the vine, and number and weight of enlarged roots, were correlated on a per-plant intra-clonal basis. Simple and partial correlation coefficients were determined. The coefficient of determination ( $r^2$ ) was computed for each significant partial correlation coefficient ( $r$ ). The yield of a sweet potato plant, expressed as weight of enlarged roots, is generally considered to have two component traits. These are the number of enlarged roots and the mean weight per root. A simple correlation between the two components was determined on a single plant basis within each of the three tested clones.

## Results and Discussion

### Clonal Productivity

The Kahera Hybrid clone produced the highest yield (26.6 t/ha in 1971). All clones tested in 1972 and 1973 gave yields which were not significantly different. Variation in yield was from 26 to 67%. The lowest coefficient of variation was encountered in 1973 where the mean yield was 18.5, 18.5, and 25.1 t/ha for clones American, Mabrooka, and Kahera Hybrid, respectively. Yabany clone was discarded after 1972 on account of its comparatively poor vegetative growth.

The fluctuation of yield from season to season was evident in clones American and Mabrooka. A similar clonal trend has been found in reports from Malaysia, the Seychelles, and Trinidad. A better judgement of clones, however, can be achieved through a combined analysis of yields over several, perhaps 5 or more, years.

Neither the number of enlarged roots nor their weight was significantly affected by the interaction between clones, planting dates, and harvest periods. The two tested clones, namely Mabrooka and Yabany, differed with respect to both number and weight of enlarged roots. A greater number and a higher weight of roots were produced by Mabrooka. The average yield was 30.8 and 2.8 t/ha in Mabrooka and Yabany clones, respectively. The weight of roots was more variable than their number. It was generally observed that the vegetative

Table 1. Mean dry matter content, colour of skin, and flesh colour and texture of enlarged roots of different clones (University of Tripoli 1973).

Clones	Dry matter <sup>a</sup> (%)	Colour		Flesh texture <sup>b</sup>
		Skin	Flesh	
American	23.4	light tan	dark orange	soft
Kahera Hybrid	22.7	copper red	light orange	soft
Mabrooka	22.3	copper red	creamy white	firm

<sup>a</sup>Coefficient of variation 3.2%.

<sup>b</sup>Texture of the cooked flesh.

growth of sweet potato plants continues for about 10 months. The vines are usually killed by frost in late December or January. Thus, planting dates in August and September could be tested in addition to the current April–June planting.

The dry matter content varied from 22.1 to 23.4% on the average (Table 1). Clone American possessed a higher dry matter than either Kahera Hybrid or Mabrooka. A report from Nigeria (Anonymous 1973) indicated the existence of sweet potato clones having up to 45% dry matter. Results of the palatability test for all clones, their flesh characteristics, and yielding ability would favour their recommendation to Libyan farmers. Many citizens and students on the campus of the University of Tripoli showed great interest in using these sweet potatoes as food. The yield per hectare, obtained in the present tests, would encourage the production of sweet potato and the expansion of its area. FAO (1975) presented data on the world production of sweet potato. A yield as high as 23.3 t/ha was reported in Cook Islands in 1973; Egypt produced a yield of 17.9 t/ha. The yield of 12 or more tons per hectare was recorded in 18 countries.

### Correlation between Characters

On an individual plant basis, the mean weight of the vines was 754, 734, and 1085 g in American, Kahera Hybrid, and Mabrooka, respectively. The mean number of roots was 3.5, 2.3, and 2.5 for the same clones. The average yield was 380 g in American, 510 g in Kahera Hybrid, and 404 g in Mabrooka. The most variable clone was Mabrooka, whereas Kahera Hybrid was the least variable. This was true for variation in each of the three characters studied. Values of the coefficient of variation ranged from 47.1 to 65.1% for vine weight, from 62.0 to 69.3% for number of enlarged roots, and from 62.0 to 96.0% for yield, i.e.

weight of enlarged roots. Within a given clone, e.g. American or Mabrooka, the weight of roots showed the highest degree of variability, the weight of vine showed the lowest variation.

The recorded interclonal variation with regard to a specific trait and intercharacteristic variation within a clone, could be attributed to the genetic control of the various characters in different clones. The contribution of yield components to yield variability was not included in the present study. Lowe and Wilson (1975a, b) found that this contribution depended on the relation between yield and either tubers number, mean tuber weight, or both components. Their data showed a greater variation for the yield of marketable tubers, i.e. enlarged roots. The same conclusion was reached in the present investigation.

Values of the simple correlation coefficient between number of enlarged roots and mean weight per root were  $-0.184$ ,  $-0.174$ , and  $-0.549$  in clones American, Kahera Hybrid, and Mabrooka, respectively. The last value was highly significant, but other values were not significant. The negative correlation found in Mabrooka clone was also reported in different sweet potato material studied by Li (1965), and Lowe and Wilson (1975a, b). The degree of association between root number and mean root weight, however, was not clear. The yield would be affected by any significant association found between these two characteristics, which are generally considered the main components of yield. The mean weight per root was not involved in subsequent types of correlations.

Simple and partial correlation coefficients for vine weight, number of enlarged roots, and yield, i.e. weight of enlarged roots, were calculated. Values of the partial correlation coefficient indicated a nonsignificant correlation of vine weight with number of roots. A similar conclusion was reached by Li (1965). Vine weight

and yield were not correlated in the Kahera Hybrid clone, but they were positively correlated in other clones. Values of  $r$  were 0.462 and 0.827 in American and Mabrooka clones, respectively. The corresponding  $r^2$  values were 0.213 and 0.684, indicating that 21.3 and 68.4% of the variation in yield of these clones can be ascribed to the effect of vine weight, keeping the number of roots constant.

Yield and number of roots showed highly significant, positive correlation in all clones. This finding is in accordance with that of Li (1965), and Lowe and Wilson (1975). The range of  $r$  values was from 0.650 to 0.705. Values of  $r^2$  were 0.497, 0.423, and 0.438 in American, Kahera Hybrid, and Mabrooka clones, respectively. This indicates that from 42.3 to 49.7% of the variation in yield of the tested clones can be attributed to the effect of number of roots, keeping vine weight constant.

Anonymous. *International Institute of Tropical Agriculture, 1973 Report. Root and tuber*

*improvement program*. Plant Breeding Abstracts, No. 9090, 1975.

FAO. 1975 *Production yearbook*. FAO, Rome, Vol. 28-1, 1974.

Haynes, P. H., and Wholey, D. W. *Variability in commercial sweet potatoes (Ipomoea batatas, L. Lam) in Trinidad*. Exp. Agric. 7, 1971, 27-32.

Li, L. *Studies on the association among yield components and their relationship to tuber yield in sweet potatoes*. J. Agric. Assoc. China, New Series, 49, 1965, 1-14.

Lowe, S. B., and Wilson, L. A. *Yield and yield components of six sweet potato (Ipomoea batatas) cultivars. I. Contribution of yield components to tuber yield*. Exp. Agric. 11, 1975a, 39-48.

*Yield and yield components of six sweet potato (Ipomoea batatas) cultivars. II. Variability and possible sources of variation*. Exp. Agric. 11, 1975b, 49-58.

Mazzochi, G. B., and Thrower, L. B. *Report to the Government of Libya on the production of fruit and vegetables*. FAO, Rome, FAO Report No. 1351, 1962.

# Summary of Discussions

## Origin, Dispersal, and Evolution

Rapporteur: D. Plucknett

Discussion Leaders: D. Plucknett, D. G. Coursey, and F. Martin

### Yams

Yams were domesticated in at least three different areas, and some have become so domesticated that the sexual process no longer exists. It is probable that the yam has been cultivated for 10 000 years or more. During this period the degree of domestication has varied. Some remain toxic or poisonous.

*D. alata* is virtually sterile, the only known seeds and seedlings have been found in the Central Tuber Crops Research Institute in India and in Bogor in Indonesia. It is probable that evolution has continued by asexual means probably through aerial tubers, which are common. In Puerto Rico one form has given rise to many subtypes over many years.

In the case of *D. esculenta*, there is still much sterility but nevertheless fertile forms exist; flowering types have been reported in the Solomon Islands. In general there is a prevalence of male flowers.

*D. rotundata* is nearly sterile but recent selection for flowering types in IITA has led to more profuse flowering types that also have higher yields. It is interesting to speculate on the criteria for selection in primitive agriculture that selected for less flowering and apparently also lower yields. For future selection of higher levels of flowering, the search should be conducted in forest areas not in the research stations

because the yam is a forest plant that under natural conditions produces seeds and seedlings.

*D. trifida* is the only wild edible yam of the Americas; originating in the Amazon basin, it flowers freely.

### Sweet Potato

No other tropical root crop has received so much research on its origins. Current theory places its origins in the new world. A hexaploid, it probably came from diploid or tetraploid forms, which may exist today in the wild. Dr Nishiyama and coworkers in Japan, have studied sweet potato origins more than any other group. They found diploid and tetraploid plants that cross with sweet potato. *Ipomoea trifida* is the only wild hexaploid plant. Dr Nishiyama believes that *I. batatas* came from *I. trifida*.

The problem of self-incompatibility of sweet potato presents problems. How and from what sources did self-incompatibility in sweet potato arise? Self-incompatibility results from three different genes. Wild lines are not self-incompatible. Where, then, are the wild progenitors that are perennial and have some degree of self-incompatibility? Nishiyama collected mainly in Mexico but maybe the ancestors of sweet potato are here somewhere in northern South America? A wild tetraploid line was found near Cali: Where are the others?

### Aroids

The aroids probably originated in forest margins or swamps. Their special adaptation to wet conditions made them useful for early man who selected the plants and devised intricate systems for growing *Colocasia* and *Cyrtosperma*.

All five main edible genera *Alocasia*, *Amorphophallus*, *Colocasia*, *Cyrtosperma*, and *Xanthosoma* are vegetatively propagated. However, the plants can produce flowers and seeds, although the conditions for this are not well understood. Seedlings can be obtained and be grown to maturity. The many varieties probably arose from chance seed setting and selection by man.

The yam/roid food crop complex was one of the earliest agricultural systems. Magnificent stone-walled irrigated terraces were constructed in Asia and Oceania by early man to grow *Colocasia*. Some anthropologists believe that *Colocasia* may have been the first irrigated crop and that rice may have been a weed of *Colocasia*.

Chromosome numbers are important in plant type. Diploid *Colocasia* have a large main corm and few cormels, whereas triploids have numerous cormels. In general, diploid and triploid plants differ somewhat in tolerance of water regime, and in crop duration.

The taxonomy of all edible aroids is confused, especially in *Xanthosoma*, *Alocasia*, and *Cyrtosperma*. Of first priority for study is the cultivated *Xanthosoma* complex.

The future of aroids will be based largely on their adaptation to difficult lands. Potential yields of *Colocasia* and *Xanthosoma* are very high.

In Asia, *Colocasia* and yams were both important as food crops, and were usually grown together. In Africa, the association between yams and aroids was not well developed.

### Cassava

There are three centres of diversity of cassava in Latin America. The State of Goias in Brazil has 38 species, Mato Grosso 70, and N.E. Brazil more than 20. In Mexico there are 17 or 18. Part of the history of dispersal of cassava is related to the Arawak Indians who originated in Venezuela or the Guyanas and moved to

Central America 2000 years ago and later returned to South America. However there is evidence that cassava was cultivated more than 6000 years ago in the North Coast of Colombia. Nevertheless the word "Yuca," used widely for cassava in South America, is an Arawak word suggesting that it may have been spread by them.

In Mexico there are only "sweet" cassavas and in Brazil there is tremendous variation. As the Indians moved north it is possible that they only took the sweet cassavas. In Mexico cassava arrived quite late, possibly after the Spanish arrived.

### **Potato**

The region near Lake Titicaca between Peru and Bolivia was probably the place of origin of the potato. Russian workers believe the point of origin was farther south, in Chile. There are many wild and cultivated species in the Andean highlands, and there are wild species of *Solanum* in Mexico and Guatemala.

## Section 2. Basic Productivity

- 70 Productivity of root crops **R. S. Loomis and H. Rapoport**
- 84 Total dry matter production, tuber yield, and yield components of six local cassava cultivars in Trinidad **E. B. Holmes and L. A. Wilson**
- 89 Effect of soil compaction on leaf number and area, and tuber yield of White Lisbon yam **Theodore U. Ferguson and Frank A. Gumbs**
- 94 The Mukibat system of cassava production **T. S. Dharmaputra and G. H. de Bruijn**
- 98 Undersowing cassava with stylo grown under coconut **I. M. Nitis and M. Suarna**
- 104 Effect of potassium on tuber yield and nutrient uptake of yams **G. O. Obigbesan, A. A. Agboola, and A. A. A. Fayemi**
- 107 Effect of potassium and sulfur on growth, yield, and composition of cassava **A. G. N. Ngongi, R. Howeler, and H. A. MacDonald**
- 113 The interaction of lime with minor elements and phosphorus in cassava production **R. H. Howeler, L. F. Cadavid, and F. A. Calvo**
- 117 Phosphorus requirement of three sweet potato cultivars **C. J. Rendle and B. T. Kang**
- 122 Effect of farm yard manure and NPK on cassava **C. R. Mohan Kumar, R. C. Mandal, G. M. Nair, and N. Hrishi**
- 124 Mineral nutrition of cassava and adaptation to low fertility conditions **D. G. Edwards, C. J. Asher, and G. L. Wilson**
- 131 Characteristics of indigenous and introduced cultivars of cassava in Guyana **A. H. Wahab**
- 137 Cassava research in Nigeria before 1972 **E. E. Umanah**
- 142 Production of cassava foliage **A. Montaldo and J. J. Montilla**
- 143 The effect of various levels of cassava leaf meal in broiler chicken rations **J. J. Montilla, R. Vargas, and A. Montaldo**
- 146 Sweet potato production, handling, curing, storage, and marketing in North Carolina **L. G. Wilson, C. W. Averre, and H. M. Covington**
- 150 Sweet potato production in Hawaii **J. S. Tanaka and T. T. Sekioka**
- 151 IBPGR and FAO programs for the collection of crop germ plasm and its long-term conservation **J. T. Sykes**
- 152 Summary of discussions **James Cock**

# Productivity of Root Crops

R. S. Loomis and H. Rapoport<sup>1</sup>

The presence of an underground storage organ introduces a unique dimension to the productivity of plants. This dimension concerns the role of the organ as a sink for photosynthates in competition with leaf and stem growth. The extended periods of time over which bulking may occur, and its indeterminate nature, means that the competition for substrate influences the dynamics of plant growth over much of the life cycle. It is important then that we understand the controls by which bulking is balanced with other growth activities of the plants.

Although root crops involve special problems in partitioning of photosynthates, other aspects of their production processes seem to be similar to most other higher plants. This discussion of productivity in root crops first examines production processes of plant communities and then considers the dynamics of partitioning to storage organ growth, and its control.

## Primary Production in Plant Communities

The radiation regime is a key factor in productivity. Above the earth's atmosphere the flux of short wave radiation averages  $2.0 \text{ cal cm}^{-2}\text{min}^{-1}$  on a surface normal to the sun's rays. In the tropical regions, where solar altitudes vary between  $66$  and  $90^\circ$  elevation at solar noon, the diurnal totals of solar radiation on a horizontal surface outside the atmosphere range from  $800$  to over  $900 \text{ cal cm}^{-2}\text{day}^{-1}$  throughout the year. With clear skies of low humidity, up to  $80\%$  of this radiation would be transmitted to the earth's surface. Most of this would be direct beam radiation and only a relatively low fraction (perhaps  $16\%$ ) would be received as diffuse skylight. Thus, the peak irradiances in the tropics can be very high, exceeding  $1.2 \text{ cal cm}^{-2}\text{min}^{-1}$ . Radiation levels of this sort are observed in the desert environments of the arid subtropical regions where irradiances of  $700$ – $800 \text{ cal cm}^{-2}\text{day}^{-1}$  are common. When irrigation is possible, these regions will support very high levels of crop production. However, the potential receipt of solar energy is greatly modified by atmospheric conditions and high radiation levels are less common in the tropics because of cloudiness and

humidity. Diurnal totals for solar radiation usually fall in the range of  $300$ – $500 \text{ cal cm}^{-2}\text{day}^{-1}$  of which  $30$ – $40\%$  may be diffuse skylight. Values of  $500$  or more are achieved only during the dry season when moisture supply may limit the extent that the plant communities can benefit from the high radiation. Tropical environments are further limited by the short days, which range from  $10.5$  to slightly over  $13$  hours. At higher latitudes in the temperate zones, daily radiation totals of  $500$  or more  $\text{cal cm}^{-2}\text{day}^{-1}$  are relatively common during the summer season. The lower solar elevation and longer days of these environments result in smaller values for peak irradiance and this can be of considerable advantage to the plant community.

The low irradiances of tropical regions are associated with smaller net radiation exchanges at the earth's surface. Net radiation is the difference between the totals of incoming and outgoing radiant fluxes and is related chiefly to exchanges of energy with latent heat and air temperature. Tropical environments thus have an advantage in low evaporative demands. In terms of primary productivity, however, the chief advantage of tropical regions lies with the length of the growing season, because other aspects of the radiation budget are generally inferior to that received during the summer season at higher latitudes. The long growing season lends an advantage to perennial crop-

<sup>1</sup>Department of Agronomy and Range Science, University of California, Davis, California 95616, USA.

ping systems with indeterminant growth habits, i.e. to crops like cassava with underground storage organs of long growth duration.

The nature of the foliage cover is an important factor in determining the efficiency with which the available solar radiation is used in primary production (Loomis and Williams 1969). The leaf area index of most root crops increases slowly after planting, due in part to the use of relatively low plant densities. Depending upon species and environment, 6–12 weeks of growth may be needed to achieve full cover (at a leaf area index of about 3). Leaf area development may change with the onset of storage organ development. Haynes et al. (1967) show for yams (*Dioscorea alata* L.) that leaf area declines as tuberization begins. A similar response occurs with potato (*Solanum tuberosum* L.) (Moorby and Milthorpe 1975). In contrast, sugar beet (*Beta vulgaris* L.) (Loomis and Bennett 1966; Campbell and Viets 1967), sweet potato (*Ipomoea batatas* L.) (Tsuno and Fujise 1965) and cassava (*Manihot esculenta* Crantz) (Enyi 1972) continue to add new leaves to the canopy during tuberization and thus are able to maintain a reasonable leaf area index throughout the season.

One way to quantify these differences is to calculate the leaf area duration (the integral of leaf area index over time). Enyi (1972) found that 75% of the variation in cassava yields related to single and multishoot treatments could be ascribed to differences in leaf area duration. Similar correlations are found with other crops. However, crop growth rate is a nonlinear function (either plateau or parabolic; Loomis and Gerakis 1975) of leaf area, and leaf area duration, as a linear integration of leaf area with time, is not the most fruitful approach. A number of studies (Williams et al. 1965; Shibles and Weber 1966) suggest that the time integral of percentage light interception may be a better index. Crop growth rates increase as a linear function of percentage interception. The slope of the relationship and the maximum rate are dependent upon canopy architecture, photosynthesis capacity of the leaves, and environment.

The length of time before full cover is achieved after planting can be a major limitation to seasonal productivity. For this reason, evergreen foliage canopies of complete cover usually attain the highest annual production rates. The period of partial cover can be short-

ened with species that have a high allocation of photosynthate to foliage production, or through dense plantings (a large number of apical meristems per unit area). However, with either of these approaches, the allocation to storage roots or tubers later in the season may be less than would be achieved with a less dominant foliage system.

The production rate also depends upon the manner of leaf display relative to the sun. A great deal has been learned about these problems through the use of light distribution simulation models (Duncan et al. 1967; Allen et al. 1974; Lemeur and Blad 1974; Monsi et al. 1973). These models are now well developed. They have been validated in a wide range of crops and environments, and can be used in predictive simulations for other environments and situations. Models have been particularly useful for analyzing the efficiency of different canopy arrangements because genetic and mechanical manipulations of leaf display generally confound photosynthesis responses with other aspects of growth and development.

Some simulations with the Duncan model (Duncan et al. 1967; Duncan 1971) are illustrated in Fig. 1. With less than full cover, plants that display their leaves horizontally in regular arrays are found to be more efficient in light interception and more rapid in the development of full cover than those with inclined leaves distributed in clumped or random distributions. With a full cover canopy of leaf area index of 3, however, productivity is nearly independent of leaf angle. With very high foliage densities, simulations for a wide range of canopy architectures show clearly that there can be a marked increase in primary productivity using erect rather than moderately inclined leaves in the top of the canopy. In tropical regions, with very long growing seasons for the accumulation of leaf density, it seems that it might be desirable to attempt to achieve erect-leaved communities of very high foliage density. The advantage of erect leaves derives from distributing a high irradiance over a large area of obliquely displayed leaves. This reduces the frequency of light saturation of leaf photosynthesis, which occurs with high irradiance per unit leaf surface. However, with the characteristic low, diffuse irradiances of the humid tropics, the advantage is not nearly as great as is shown in Fig. 1 for clear skies in the temperate zone.

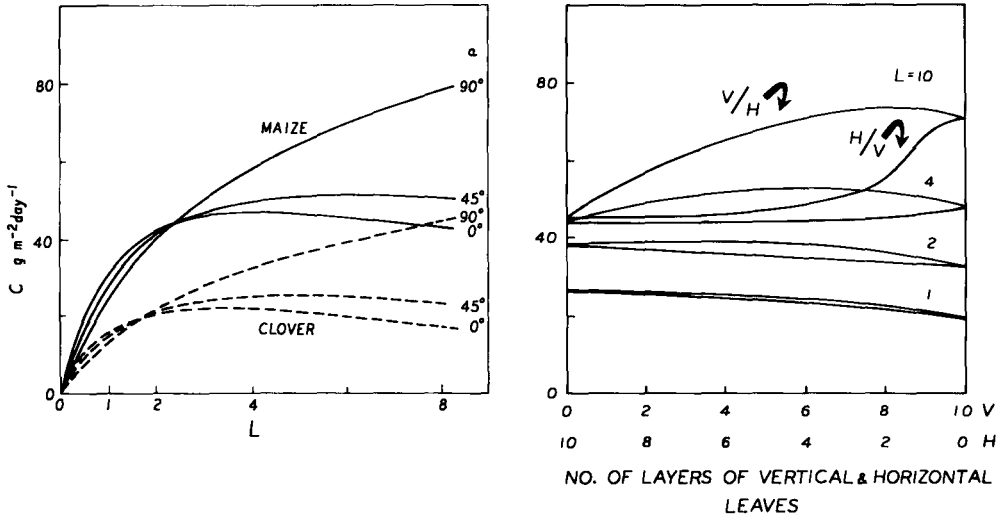

Fig. 1. (Left) Simulations with the Duncan model of crop growth rates ( $C$ ) for communities of  $C_4$  and  $C_3$  plants of various leaf area index ( $L$ ) and leaf elevation angle ( $\alpha$ ). The canopies are composed of 10 strata of randomly dispersed leaves. Solar and skylight data of  $38^\circ\text{N}$  latitude, 1 July (after Loomis and Williams 1969). (Right) Simulations of crop growth rates for "best" and "worst" possible combinations of leaf angles at leaf area indices ( $L$ ) of 1, 2, 4, and 10. Each canopy has 10 strata of leaves; the horizontal axis indicates the number of strata with vertical ( $V$ ) and horizontal ( $H$ ) leaves. The best canopies (upper lines in each case) have  $V$  leaves on top and  $H$  leaves in the lower strata. The worst canopies have  $H$  in upper strata,  $V$  in lower.  $C_4$  plant; solar and skylight data of  $40^\circ\text{N}$  latitude, 1 July (after Duncan 1971).

The influence of diffuse radiation on productivity has been considered in detail by Allen et al. (1974). Our own work with the Duncan model is illustrated in Fig. 2. The proportion of diffuse radiation ( $H_D/H$ ) increases with increasing cloudiness, but this is associated with a sharp decline in the fraction of potential radiation that reaches the earth's surface ( $H/H_0$ ) (Fig. 2, left). At any given radiation level (Fig. 2, right) simulated production rates increase as the proportion of diffuse radiation increases, but this effect is more than offset by the reduction in total radiation (connecting line). Although less pronounced with canopies of horizontal leaves and with zenith-bright skies, the decline was found for all canopies, dates, and latitudes.

There are several other difficulties associated with the achievement of dense foliage canopies in the tropics. With a specific leaf area of  $2\text{--}3\text{ dm}^2\text{g}^{-1}$ , the dry matter of a hectare of leaves will range between 375 and 500 kg in blade material alone. With a protein content of 15–18%, 9–15 kg N ha<sup>-1</sup> are required for each unit of leaf area index. Foliage canopies with leaf area indices of 8–10 thus require cycling

of 70–150 kg N ha<sup>-1</sup>yr<sup>-1</sup> for leaf blades alone. This is a difficult proposition in most tropical environments. Very high annual productivities have been achieved in tropical regions with certain grass species with net production in the range of 50–80 or more MT ha<sup>-1</sup> (Loomis and Gerakis 1975). These crops involved the development of extremely dense foliage canopies but 1000–2000 kg N ha<sup>-1</sup> of supplemental fertilizer were required. This suggests that photosynthetic capability is not the principal limitation to yields in the tropics.

There are a number of reasons, then, that point to the use of relatively low leaf-area indices for optimizing the production of root crops in tropical environments. With a low leaf area index, a high proportion of the leaf surface will be exposed to irradiances sufficient for saturation of leaf photosynthesis. And if water and nitrogen are not limiting, the question of the photosynthetic capabilities of root crops assumes some importance. Photosynthetic gas exchange in sugar beet, potato, and sweet potato have been studied rather well, but very little information has been developed for other root crops. In general, these plants all

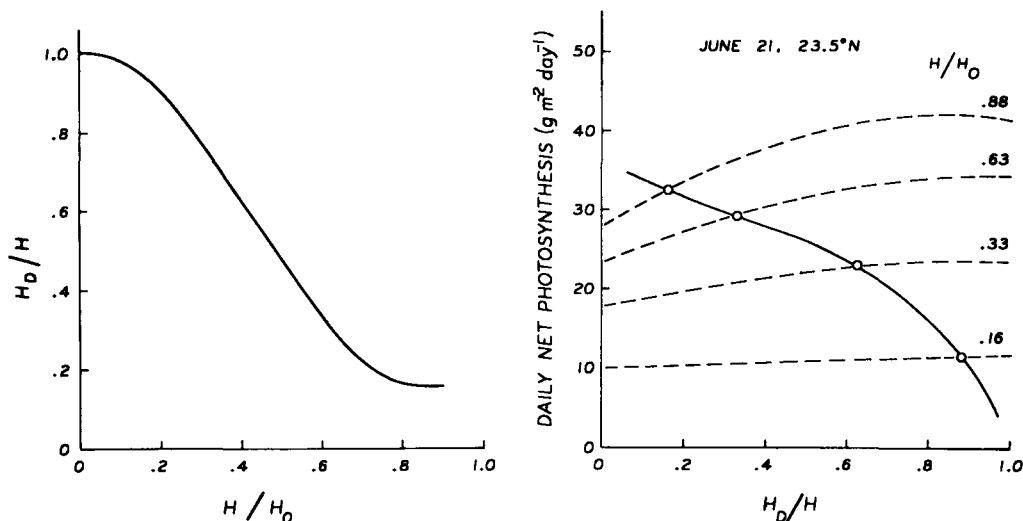

Fig. 2. (Left) Liu and Jordan's (1960) observations of the fraction ( $H_D/H$ ) of daily total radiation on a horizontal surface ( $H$ ) received as diffuse skylight ( $H_D$ ) as a function of  $H/H_0$ , the fraction that daily total radiation was to that received outside the atmosphere ( $H_0$ ). The observations were made throughout the year in the northern hemisphere; a high proportion of diffuse radiation occurs with high cloudiness and hence with a low proportion of daily total radiation. (Right) Simulations with the Duncan model of community photosynthesis rates with varying proportions of diffuse skylight ( $H_D/H$ ) from a uniform overcast sky. Photosynthesis rate increases at each radiation level as  $H_D/H$  increases. The points and connecting line indicate the situation for "real" skies using the Liu and Jordan relationship shown to the left. The reduction in radiation offsets the more efficient distribution of radiation within the canopy and photosynthesis decreases as cloudiness increases. Solar data for 23.5°N latitude, 21 June,  $C_3$  plant.

have a  $C_3$  pattern of carbon metabolism. They can achieve a high quantum efficiency at low irradiances, but they are susceptible to light saturation with 0.4–0.5  $\text{cal cm}^{-2} \text{min}^{-2}$  of sunlight. The ribulose diphosphate carboxylase enzyme system of  $C_3$  plants has a low affinity for  $\text{CO}_2$  and assumes a role of an oxygenase enzyme under saturating light conditions (Schrader 1976). When water and nutrients are not limiting, such plants can achieve high levels of production, but the levels are still considerably below the records set in similar environments by tropical grasses and other species with a  $C_4$  type of metabolism (Loomis and Gerakis 1975).  $C_4$  species can achieve good rates of photosynthesis even when carbon dioxide concentration within the leaf is quite low, i.e. at high light or when the stomates are partially closed. This lends a capability to the  $C_4$  species for a greater water use efficiency (Downes 1969) and many ecologists feel this may be the principal advantage of the  $C_4$  mechanism.

It seems unlikely that the  $C_4$  metabolic system can be easily introduced into  $C_3$  plants; the inheritance is complex and the transfer has not been successful even in the few instances as in *Atriplex* where the two systems were found in closely related species (Bjorkman 1976). The alternative is to select for higher photosynthesis capability within  $C_3$  plants. Little progress has been made in this direction, perhaps because environmental factors have strong influences on the system and our approaches have been relatively crude. Recent results with  $C_3$  tomato (Augustine et al. 1977) are much more promising.

Regardless of the outlook in breeding, it would be helpful if we had more information on the photosynthetic capabilities of the root crop species. Response functions to temperature, light, and carbon dioxide concentration and their variation are needed. Good quality data on these functions can be obtained only through the use of fairly sophisticated gas exchange systems. Attempts to approach the

problem through growth analyses techniques (e.g. calculation of net assimilation rates by dividing the crop growth rate by leaf area index) have been less satisfactory. NAR values are highly sensitive to environment since they integrate the daily patterns of temperature and solar radiation as well as the manner and density of leaf display and the respiratory activities of nonfoliage parts. Even when extrapolated to 0 leaf area index, NAR values may bear little relationship to the photosynthetic capability of a particular plant. Comparisons of NAR rates within or between species thus have provided little information about the morphological and physiological properties of the particular photosynthetic system.

Solar radiation flux, foliage architecture, and photosynthetic capability, then, are the principal factors affecting primary productivity. In the field, there are many subtle variations in these or other factors that add to the complexity of the situation. The placement of plants in rows, the use of species mixtures, deliberately or inadvertently within the plant community, and the phototropic movement of leaves are simple examples. Fukai and Loomis (1977) have developed a photosynthesis simulator for row-planted crops. The validated model predicts a 30% greater production rate when leaves of a cotton crop are uniformly distributed over the land rather than being clumped in rows. They also found that phototropic movements in cotton, which tend to maximize the proportion of leaves displayed normally to the sun's rays, can be advantageous to production rates with a small leaf area index. Williams and Ghazali (1969) have found movements in the upper leaves of cassava, with a tendency toward vertical orientation at night and a change to moderate angles of display during daylight hours. There were differences among varieties in the average leaf angle, the amount of diurnal change, and in the occurrence of a mid-day drooping to a more vertical leaf angle. The presence of disease or insect damage and the influence of leaf age may also become important factors in production. All of these features are susceptible to study and improvement. The supply of carbon dioxide, in contrast, is much more difficult to modify, yet it is probably a limiting factor during the mid-day period in most agricultural systems. Carbon dioxide is normally limiting under intense radiation and the extent to which this limitation is enhanced by depletion of carbon dioxide from

the air within the crop is strongly dependent upon the efficiency of eddy transfer and hence on wind speed. Again, this will be less of a problem in the tropics with low radiation.

### Partitioning

The allocation of new assimilates to respiration, growth, and storage is the second feature of the production system. Photosynthesis may be rather intimately associated with partitioning. As we saw earlier, in considering the dynamics of foliar development, partitioning to leaf growth has a strong control on the increase with time of community light interception and hence photosynthesis. In addition, photosynthesis rates may be depressed in some cases by the lack of active growth and storage sinks. Although final yields are obviously dependent upon photosynthesis, crop physiologists have had difficulty in correlating variations in yield components with photosynthesis rate. The extensive work by Wallace et al. (1976) with bean, as an example, illustrates the difficult morphological questions that are encountered. We will look briefly at respiration as an aspect of partitioning before turning to the morphogenetic questions that lie at the heart of the partitioning problem.

### Respiration

Plant biologists have had a tendency to treat respiration rather casually and to consider it primarily as a wasteful drain on assimilate supply. Our understanding and conceptualization of respiration in higher plants has been advanced markedly in the past few years. McCree (1971) identified two main components of whole-plant respiration: one part associated with the cost of maintaining the existing system; and a second part, which in his formulation is proportional to the photosynthesis rate. The second term corresponds to the energy cost of biosyntheses and growth. His formulation parallels the position that microbiologists had reached earlier (e.g. Pirt 1965).

Smith (1949) and other early workers in photosynthesis recognized that the amount of respiration would be heavily dependent upon the end products of growth and photosynthesis. Penning de Vries (1974) and Penning de Vries et al. (1974) have formulated this approach rather rigorously in a classic study. Using current concepts of metabolic pathways, they calculated the energy and material costs of synthesis from primary photosynthate for each

Table 1. Balance sheet for respiration associated with biosynthesis and growth of biomass in young corn plants. Amino acid, protein, and organic acid compositions appropriate to corn were used (after Penning de Vries et al. 1974).

Compounds	Fraction of plant $\left(\frac{\text{g}}{\text{g biomass}}\right)$	PV <sup>a</sup> $\left(\frac{\text{g glucose}}{\text{g product}}\right)$	Substrate use $\left(\frac{\text{g glucose}}{\text{g biomass}}\right)$	O <sub>2</sub> consumed (g)	CO <sub>2</sub> produced (g)
Nitrogenous					
Amino acids	0.023				
Protein	0.200				
Nucleic acid	0.077				
	<u>0.230</u>	0.620	0.371	0.00208	0.0924
Carbohydrates					
Sugars	0.085				
Cellulose	0.226				
Hemicellulose	0.226				
Pectin	0.028				
	<u>0.565</u>	0.853	0.662	0	0.0377
Lipids	0.025	0.351	0.071	0	0.0355
Lignin	0.080	0.483	0.166	0.00735	0.0404
Organic acids	0.050	1.104	0.045	0	-0.0023
Minerals	0.050	0	0	0	0
Respiration for additional ATP and NADH <sub>2</sub> production, ion uptake, and glucose transport	0	—	0.223	0.18000	0.3280
<i>Total</i>	<u>1.00</u>		<u>1.538</u>	<u>0.189</u>	<u>0.530</u>

<sup>a</sup>PV is the "product value", g product achieved per g glucose consumed starting with NO<sub>3</sub>-N and SO<sub>4</sub>-S, but unbalanced for total ATP and NADPH<sub>2</sub> needs that are balanced at the bottom of the table for the whole plant. The net product value, 1.00 g biomass/1.538 g glucose = 0.650.

type of primary plant product. For example, starting with glucose, they totaled the number of ATP and NADH<sub>2</sub> molecules required in a least-cost pathway for the synthesis of each amino acid and for the assemblage of these into typical proteins. The same process was followed with carbohydrates such as cellulose, lipids, nucleic acids, and other products. Associated with these biosyntheses were identifiable but less certainly determined costs associated with transport, gradient maintenance, and turnover of proteins and nucleic acids. Detailed tables giving product yields (g product/g glucose) for all of the important constituents of higher plants were presented. Starting with nitrogen and sulfur in reduced or oxidized forms, a summary of their calculations for the biochemical composition of typical corn plant material is shown in Table 1. Two key points are evident. First, the respiration cost for the synthesis of lipids and proteins is very high in

comparison to that for carbohydrate fractions; plants with a high proportion of carbohydrates in their biomass will have a greater weight yield per unit of photosynthate. Second, even though corn plant material has a relatively low protein and lipid content, about 25% of the original photosynthate supply is consumed by respiration associated with syntheses (growth). This percentage agrees well with McCree's estimates of the growth-associated respiration of clover (McCree 1971) and sorghum (McCree 1976) plants.

Respiration budgets of this sort apply only on a whole plant basis. One of the largest energy costs, for example, is the reduction of nitrate. In many plants, this is accomplished largely in the leaves with some direct participation of photosynthetic energy sources. The growth respiration for nitrogen metabolism of a storage organ on the other hand involves only the cost of assembling these amino acid

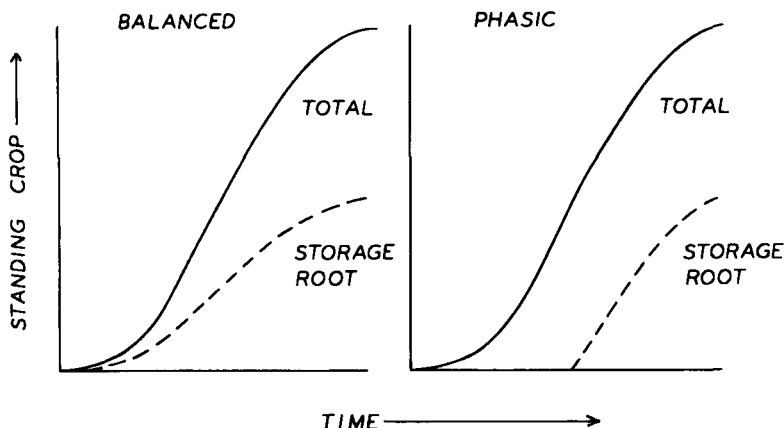

Fig. 3. The time course of two types of partitioning observed in root and tuber crops. (Left) Continuous partitioning. (Right) Phasic partitioning.

units into proteins. If the protein and lipid levels of storage organs are low, the growth respiration will also be relatively low. The maintenance respiration of storage organs also can be very low if a high proportion of the dry matter is carbohydrate and is compartmentalized in starch grains.

### Source-Sink Relations

The other aspects of the partitioning process seem to centre principally on the relative activity of photosynthate sinks (Evans 1975). Agricultural crops usually are grown under conditions that result in fairly intense interplant competition and if nutrients and water are not limiting, source activity is usually the most limiting part of the system. Limitations due to sink activity and transport capacity, however, can be demonstrated. Through manipulations such as the removal of developing fruits or girdling (Humphries 1967; Neales and Incoll 1968), carbohydrates accumulate in leaf and stem tissues and photosynthesis is usually depressed. The negative feedback on photosynthesis might occur at any of several steps in the process. A direct repression of carboxylase enzymes has not yet been demonstrated and the mechanisms for assimilate control of photosynthesis remain unresolved (Thorne and Koller 1974). However, as Evans (1975) concludes, source-sink and transport systems are relatively well balanced in most crop plants to the side of source limitations.

As illustrated in Fig. 3, there are two general patterns of partitioning during the growth and development of plants with underground

storage organs. In one type, characterized by the sugar beet, storage organ growth begins early in the seedling stage and continues throughout the vegetative period of the plant. There is an indeterminate competition between shoot growth (particularly of new leaves) and storage organ growth. Shoot growth retains a priority for assimilate supply even though the relative magnitude of top and root may change as root size increases. A balance between these two activities is maintained throughout the growing season. In the other type of partitioning, early vegetative growth is characterized by shoot and fibrous root development. Storage organ growth begins later, is usually more determinate in nature, and often requires an inductive environment. Examples of this type of growth include the potato and cassava, some varieties of which begin tuberization after being exposed to short days (Bolhuis 1966; Gregory 1956; Okigbo 1971). The switch to storage organ growth may be quite dramatic with a subsequent cessation and/or even negative growth of shoot tissues.

### Balanced Partitioning: The Sugar Beet

The balancing mechanisms between shoot and storage organ growth in plants such as the sugar beet may be based on several functional activities. In shading or crowding experiments we can demonstrate a sequence of priorities in the utilization of a limited supply of photosynthate. The growth of new leaves clearly has priority over fibrous roots and both of these have priority over storage root growth. We do not understand how this priority series is estab-

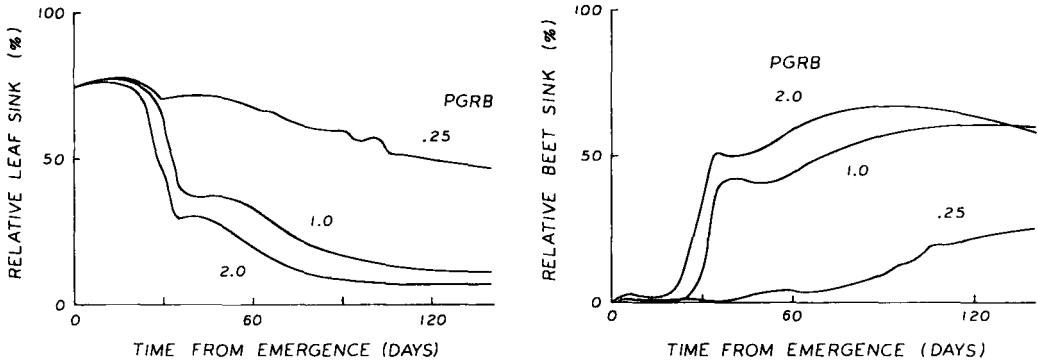

Fig. 4. Simulations with a dynamic, integrative physiology model (SUBGOL; Hunt 1974; Loomis et al. 1976) of growth sink activities for sugar beet. Relative sink activity is expressed as a percentage of the total daily allocations of photosynthate to growth, storage, and respiration. The model responded to long-term weather data for Sacramento, Calif., (38°N latitude); emergence was on 16 May with 7 plants  $m^{-2}$ . Possible Growth Rate of Beet (PGRB) is varied as a genetic opinion with 1.0 corresponding to sugar beet, 2.0 representing mangel, and 0.25 representing Swiss chard. (Left) Leaf growth sink. (Right) Beet growth sink.

lished and maintained. The relationship between fibrous root and storage root growth is particularly interesting since transport to fibrous roots in the sugar beet occurs past the actively growing vascular cambia of the storage root. One direction for research is to examine the controls over phloem loading and unloading (Wardlaw 1974).

In addition to the top-down priority in photosynthate distribution, there seems to be a reverse order of influences for deficiencies of nutrients and water acquired by the roots. Stresses for these factors are usually more limiting to shoot growth than for the growth of fibrous roots and underground storage organs. Brouwer and de Wit (1969) have formulated the top-down photosynthate priority and the root-up priority for water into a "functional balance" hypothesis to explain the maintenance of root/shoot ratios in plants. Finally, correlative controls provided by plant hormones also play a key part in the allocation process. The role of auxins in apical dominance in shoots provides a classic example (Phillips 1975). Fluxes of abscisic acid and cytokinin from roots also serve to regulate shoot growth (Leopold and Kriedemann 1975). Correlative controls over the activity of underground organs will be considered later. Unfortunately for our understanding of whole-plant processes, there has been very little study of the interactions between substrate supply and hormones in the control of growth and development.

Our own research on this problem has been

greatly aided by the development of a dynamic simulation model of the sugar beet production system (Fick et al. 1973, 1975; Hunt 1974). The model is based on tissue and organ level physiology and attempts to integrate the relative activity of sources and sinks into a behavior of whole plants and crops. The structure of the model and its behavior then represent a hypothesis for the controls over partitioning in sugar beet. The simulations illustrate clearly a transition from foliage dominated growth to storage root dominated growth (Fig. 4). The initial size of the future storage organ (the hypocotyl and primary root axis) is too small at emergence, even with maximal activity of the cambia, which develop very early in the seedling stage (Winter 1954; Milford 1973), to use a significant proportion of the available photosynthate. In the model, leaf growth thus wins in the early competition for the limited supply of photosynthate. As a result, photosynthate supply expands rapidly, more rapidly in fact than the capacity for root growth. This additional photosynthate allows successive leaves to reach a larger and larger size (Fig. 5, middle). The potential photosynthesis per plant is determined by density, which establishes the area of the sunlight available per plant. As the tops expand to fully occupy this area, the photosynthesis rate per plant comes to a maximum value. With a single apical meristem per plant, the capacity of the leaf sink has a ceiling determined by the (leaf initiation rate)  $\times$  (growth capacity of the ex-

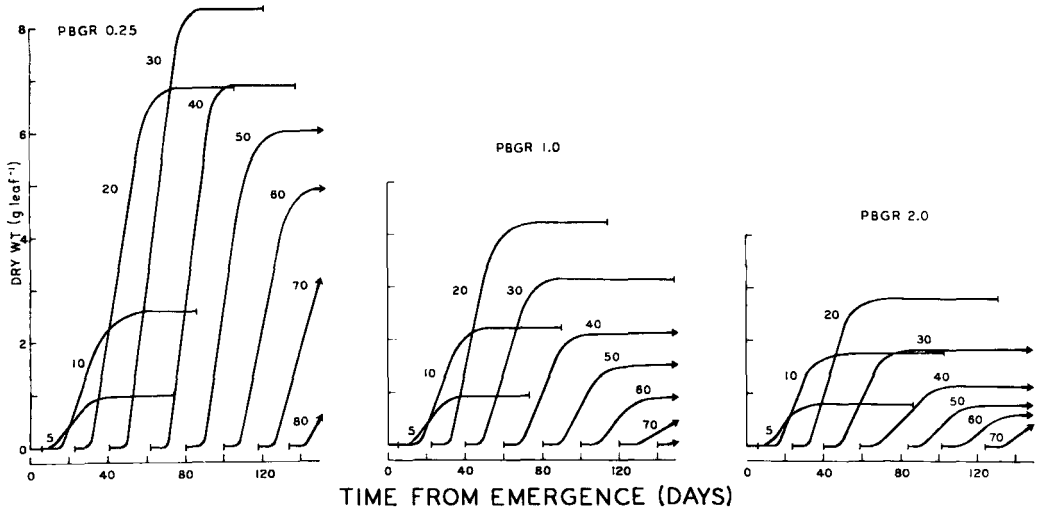

Fig. 5. Simulations with SUBGOL of the growth in weight of successively numbered leaves of sugar beet plants. Inputs are the same as in Fig. 4. (Left) Leaf growth in competition with chard root. (Middle) Leaf growth in competition with sugar beet root. (Right) Leaf growth in competition with mangel root.

panding leaves)  $\times$  (the number of plants per unit area) (Loomis et al. 1976). During this period, the storage root has continued to expand and increase in its capacity for growth, which eventually exceeds not only the growth capacity of the shoot but also of the photosynthate supply. The result is the transition from shoot-dominated growth to root-dominated growth illustrated in Fig. 4.

It is significant that the shoot continues to be an effective competitor for the limited supplies of photosynthate. The explanation for this seems to be that the leaf initiation rate is relatively unaffected by competition for substrate and that the developing leaves maintain a priority for assimilates, including their own, during their initial period of growth. The final mature size of the later leaves is smaller than those that mature earlier without significant competition from the storage root (Fig. 5).

The sensitivity of the partitioning system is revealed by altering the "genetic" opinions introduced into the model. For example, we can vary the "possible growth rate" of the storage organ. In real plants, this might correspond to changes in the number of cambia in the storage organ, or in their cell division rates, or in the capacity to transport assimilates from the shoot. By reducing this possible growth rate by a factor of 0.25, we markedly delay the transition to storage root-dominated growth and also

reduce the degree of root dominance (Fig. 4). Also shown in Fig. 4 is the result of doubling possible root growth, corresponding to a genetic opinion for the mangel. The results correspond to the differences observed in real plants between sugar beet and Swiss chard, and mangel, which are all members of the *Beta vulgaris* species. In the simulation, the reduced capacity for root growth allows the assimilates to be used in leaf growth and development. Figure 5 illustrates simulations of leaf growth for beet, chard, and mangel and shows clearly the kinds of leaf-size differences observed with real plants.

We do not know whether real plants control these aspects of partitioning through "possible growth rates" of roots, or by analogous controls over shoot growth (Loomis et al. 1976) although we have some confirmation for root control of partitioning in *Beta* species through reciprocal grafts of sugar beet and chard. Chard plants normally develop very large leaves, but when grafted to a sugar beet stock with a very strong capacity for storage organ growth, the resulting chard leaves are smaller, particularly in their petiole weights (Fig. 6). The reverse is true when beet shoots, which normally have smaller leaves, are grafted to chard stock. The chard root is unable to effectively use a large proportion of the assimilate and beet leaf growth is greater than when the

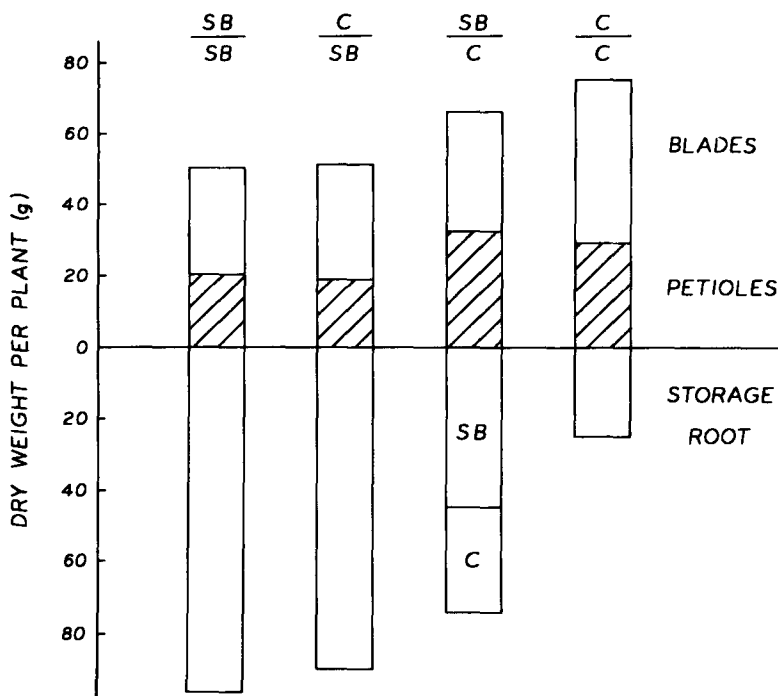

Fig. 6. Dry weights of underground storage organs and leaves, separated into blades and petioles, from grafted plants of sugar beet and chard. The grafts were made in the seedling stage with apical buds as scions. The leaves developed in competition with active thickening of the storage roots. SB/SB, C/SB, SB/C, and C/C indicate scion/stock sources as sugar beet (SB) or chard (C). With SB/C, a very small amount of hypocotyl tissue that was transferred with the apical bud developed significant cambial activity, and the proportions of those roots derived from SB and C are indicated.

beet leaves compete with the strong sugar beet storage root.

The chard-beet grafts indicate that much of the control over the capacity for storage root growth is an inherent characteristic of the root genotype. Similar conclusions can be drawn from grafting experiments with other root and tuber crops including sweet potato (Wilson 1967; Hozyo et al. 1971; and Hozyo and Park 1971), potato (Bunemann and Grassia 1973), cassava (Mogilner et al. 1969; de Bruijn and Dharmaputra 1974) and earlier work with sugar beet by Thorne and Evans (1964).

These experiments and simulations reveal the main features of the chard/beet, root/top partitioning system and lend support to the thesis that assimilate supply plays a role in control. Two directions for further research are indicated. One is to ascertain whether there are basic differences in cell division and expansion between chard and sugar beet storage roots. The chard plant actually has a greater number

of cambia layers, so its lower capability for growth must rest with either a lower rate of cell division/enlargement when unrestrained by substrate, or with a lower priority in acquisition of photosynthates from the shoot. Again, it is unclear whether such a lower priority could also result from a higher growth capability in shoots or some limitation in phloem transport. Chard plants actually have a lower rate of leaf initiation, so the principal difference, if it rests in shoot growth potential, has to fall to the number of cells and their final size within the developing leaves. Nutritional control of partitioning could also be exercised in a number of other ways. We should not overlook, for example, the possibility that there are marked differences in these plants in the capacity or mechanisms for phloem loading and unloading (Wardlaw 1974). This would directly affect, in a nutritional sense, the priorities of shoots and roots.

The second area of research involves in-

vestigations of the correlative influences over root and shoot activity. In experiments in which we have used the radish plant (*Rhaphanus sativus* L.) as a model of vascular cambial activity in underground storage organs, we discovered that auxin must be present for the initiation of a vascular cambium, and that cell division is sustained only if a cytokinin is also present (Loomis and Torrey 1964). Peterson (1973) has confirmed and extended these findings for the turnip. In sterile culture, the thickening of excised radish roots is independent of the presence or absence of the root tip suggesting that the supply of cytokinins from this source is not a factor in vascular cambium activity. This conclusion is reinforced by the demonstration of polar transport within radish hypocotyls and root sections in which auxin and cytokinin both are preferentially transported from the shoot towards the root end of these tissues (Radin and Loomis 1974). Thickening fails to occur when the hormones are supplied from the root tip end of a root or hypocotyl segment.

We may find that hormones do not serve as quantitative control agents over the degree of partitioning. Instead, they may act as switches to initiate events and subsequent variations in cambial activity may be more strongly determined by nutrition than by the hormonal milieu. Lawrence and Barker's (1963) study on the role of the carbon source for the tuberization of potato supports this view.

### Phasic Partitioning

The partitioning patterns of many root and tuber crops may be more determinate than in the sugar beet. The same aspects that we discussed for balanced partitioning (e.g. cell division and nutritional control) also apply here; the principal difference lies with *initiation* of storage organ growth. The early growth period is similarly dominated by shoot and fibrous root growth, but it is without competition from storage organs and may be of extended duration. Storage organ growth is initiated later in the life cycle, frequently in response to an environmental signal, and may completely dominate subsequent growth. In many respects, the situation is analogous to the determinate, phasic development of cereal grains. However, it is sometimes difficult to discern these differences in practical situations and the point may have utility more for ordering our thinking about physiological controls and plant

breeding than for crop management. One reason is that a species may show phasic development in one environment where the inductive stimulus is seasonally present, but not in another, continuously inductive environment.

Photoperiodic induction of storage organ growth serves as one example of phasic controls. Beginning with the work of Garner and Allard (1923) we now know that fleshy root or tuber development in some varieties of potato (*S. tuberosum* L.), runner bean (*Phaseolus coccineus* L.), yam (*Dioscorea alata* L.), and Jerusalem artichoke (*Helianthus tuberosus* L.), *Dahlia*, *Begonia*, *Ullucus tuberosus*, *Oxalis tuberosa*, radish, cassava, and other species requires or is strongly stimulated by photoperiods shorter than 10–12 hours (long nights). It is interesting that both root and stem structures respond. Considerable genetic variation exists within species. Some radish varieties, for example, seem to require short days for thickening; others are neutral or accelerated by long days.

Nitsch (1971) and Leopold and Kriedemann (1975) have reviewed the present status of the physiological controls of short-day induction. The key findings include Nitsch's (1965) observation that tuber formation can be prevented in Jerusalem artichoke by a red light break during the dark period. With the same species, Hamner and Long (1939) found that the photoperiodic stimulus was perceived in leaves and that the influence was transmitted through grafts to noninduced plants (see also Gregory 1956). Most intriguing, leaves of sunflower (*H. annuus* L.) generated a short-day stimulus that induced tuberization in the artichoke (*H. tuberosus* L.) (Nitsch 1965). Induction may be quantitative; some plants are fully induced by a few photocycles but 'Sneezy' dahlia gave a linear increase in tuberization over the range of 4–28 inductive days (Moser and Hess 1968).

Hormonal control of tuberization in photoperiodic susceptible species may be complex. Palmer and Smith (1970) initiated tuberization in isolated potato stolons through an application of cytokinin. Extensive starch accumulation was the first event in the initiation process, an event that is inhibited by gibberellins. It is noteworthy that gibberellins also inhibit tuberization. They are present in elongating tips but decline rapidly with inductive treatment (Railton and Wareing 1973). Similar results have been found with *Dahlia* (Biran

et al. 1974) where abscisic acid promotes root tuberization in plants on noninductive long days but gibberellin inhibits it. Forsline and Langille (1975) found that inducing conditions caused a very marked increase in cytokinin activity in potato shoots after two inductive cycles; the active cytokinins reached maximum values in below-ground tissues after 6 days and tubers were initiated after 8–10 days. It may be that transport of a cytokinin from shoot to root, parallel to that hypothesized for radish (Loomis and Torrey 1964), serves as the photoperiodic stimulus.

One other feature of phasic partitioning deserves comment. Once tuberization has begun, the competitive effects on shoot growth may be quite dramatic, even to the extent that shoot growth may be completely suppressed. Again, we find both nutritional and hormonal theories proposed for control. In potato, the haulm actually undergoes negative growth as materials are redistributed to the developing tubers (Moorby and Milthorpe 1975). Vegetative "cutout" also occurs in other systems, e.g. cotton, an indeterminate flowering plant, where apical growth ceases during heavy fruit development. Of the many relevant observations, it may be noteworthy that shoot growth inhibition occurred in some experiments with *Dahlia* when tuberization was promoted by short days or by foliar sprays of abscisic acid under noninductive long days (Halevy and Biran 1975). It remains to be seen whether storage roots and tubers release growth inhibitors that serve in the mobilization of resources from the rest of the plant.

It appears that photoperiodic control (and similarly temperature controls, which we have not discussed) may provide a functional balancing of shoot and underground organ growth, over time, for species in which tuberization, once initiated, is an over-dominant process. The control exists in many tropical root and tuber crops. Threshold daylengths are rather precise, usually in the range of 11–12 hours and the phenomenon may be important to the seasonal behaviour of some species within the tropics. Other species might carry the trait but exist always in the induced state in their native latitudes; tuberization would be continuous in the tropics (and hence balanced by other mechanisms as with the sugar beet) but highly seasonal at higher latitudes. Cassava's narrow geographical range near the equator is probably related to photoperiodic

control (Bolhuis 1966; Jennings 1970). The trait should be considered in grafting studies (e.g. Wilson 1967) as well as in plant breeding and crop management.

### Models in Root Crop Productivity

The production systems of crop plants involve a very large number of plastic elements. It is increasingly necessary when attempting to develop integrative explanations or predictions about systems to turn to simulation models as an aid for dealing with the complexity. We have seen that our present understanding of light interception, photosynthesis, and the partitioning aspects of plant growth have been greatly assisted through the use of such models. Many of these involve adaptive controls and thus respond to the changing nature of the plants and their environments.

A feature missing from such models has been an ability to simulate the hormonal regulation of adaptation and development. In models such as the sugar beet growth simulator, these concepts are simply entered as "genetic" rules. Radin (1970) outlined a hormonal control model for radish root development, including secondary growth and Wilson (1975) in an eloquent essay has gone further and outlined a scheme for modeling the interaction of hormonal and nutritional controls. This may be one of the tools needed, plus a great deal more information on physiology and morphology, before we can provide plant breeders and production experts with an integrated understanding of root and tuber crops.

The assistance of M. B. Carter, W. A. Williams, E. Ng, and W. F. Hunt in the simulations for Fig. 1, 2, 4, and 5 is appreciated. Supported in part by NSF Grants GB 14581 and 18541.

- Allen, L. H. Jr., Stewart, D. W., and Lemon, E. R. *Photosynthesis in plant canopies: effect of light response curves and radiation source geometry*. *Photosynthetica*, 8, 1974, 184–207.
- Augustine, J. J., Stevens, M. A., and Breidenbach, R. W. *Inheritance of carboxylation efficiency in tomatoes*. *Hort. Sci.* 1977 (in press).
- Biran, I., Lesham, B., Gur, I., and Halevy, A. H. *Further studies on the relationship between growth regulators and tuberization of dahlias*. *Physiol. Plant.* 31, 1974, 23–28.
- Björkman, O. *Adaptive and genetic aspects of C<sub>3</sub> photosynthesis*. In Burris, R. H., and Black, C. C., eds., *CO<sub>2</sub> metabolism and plant productivity*. Univ. Park Press, Baltimore, Md., 1976, 287–309.

- Bolhuis, G. G. *Influence of length of the illumination period on root formation in cassava, Manihot utilissima Pohl.* Neth. J. Agric. Sci. 14, 1966, 251-254.
- Brouwer, R., and de Wit, C. T. *A simulation model of plant growth with special attention to root growth and its consequences.* In Whittington, W. J., ed., *Root growth.* Butterworth, London, 1969, 224-244.
- Bruijn, G. H. de, and Dharmaputra, T. S. *The Mukibat system, a high-yielding method of cassava production in Indonesia.* Neth. J. Agric. Sci. 22, 1974, 89-100.
- Bunemann, G., and Grassia, A. *Growth and mineral distribution in grafted tomato/potato plants according to sink number.* Sci. Hort. 1, 1973, 13-24.
- Campbell, R. E., and Viets, F. G. Jr. *Yield and sugar production by sugar beets as affected by leaf area variations induced by stand density and nitrogen fertilization.* Agron. J. 59, 1967, 349-354.
- Chapman, T. *Some investigations into factors limiting yields of the white Lisbon yam (Dioscorea alata L.) under Trinidad conditions.* Trop. Agric. Trin. 42, 1965, 145-151.
- Downes, R. W. *Differences in transpiration rates between tropical and temperate grasses under controlled conditions.* Planta, 88, 1969, 261-273.
- Duncan, W. G., Loomis, R. S., Williams, W. A., and Hanau, R. *A model for simulating photosynthesis in plant communities.* Hilgardia, 38, 1967, 181-205.
- Duncan, W. G. *Leaf angles, leaf-area, and canopy photosynthesis.* Crop Sci. 11, 1971, 482-485.
- Enyi, B. A. C. *Effect of shoot number and time of planting on growth development and yield of cassava (Manihot esculenta Crantz).* J. Hort. Sci. 47, 1972, 457-466.
- Evans, L. T. *The physiological basis of crop yield.* In Evans, L. T., ed., *Crop physiology.* Cambridge Univ. Press. Cambridge, U.K., 1975, 327-355.
- Fick, G. W., Loomis, R. S., and Williams, W. A. *Sugar beet.* In Evans, L. T., ed., *Crop physiology.* Cambridge Univ. Press. Cambridge, U.K., 1975, 259-295.
- Fick, G. W., Williams, W. A., and Loomis, R. S. *Computer simulation of dry matter distribution during sugar beet growth.* Crop Sci. 13, 1973, 413-417.
- Forsline, P. L., and Langille, A. R. *Endogenous cytokinins in Solanum tuberosum as influenced by photoperiod and temperature.* Physiol. Plant. 34, 1975, 75-77.
- Fukai, S., and Loomis, R. S. *Leaf display and light environments in row-planted cotton communities.* Agric. Meteorol. 1977 (in press).
- Garner, W. W., and Allard, H. A. *Further studies in photoperiodism, the response of the plant to relative length of day and night.* J. Agric. Res. 23, 1923, 871-920.
- Gregory, L. E. *Some factors for tuberization in the potato plant.* Am. J. Bot. 43, 1956, 281-288.
- Physiology of tuberization in plants.* Handb. Pflanzen-Physiol. 15(1), 1964, 1328-1354.
- Halevy, A. H., and Biran, I. *Hormonal regulation of tuberization in dahlia.* Acta. Hort. 47, 1975, 319-329.
- Hammer, K. C., and Long, E. M. *Localization of photoperiodic perception in Helianthus tuberosus.* Bot. Gaz. 101, 1939, 81-90.
- Haynes, P. A., Spence, J. A., and Walter, C. J. *The use of physiological studies in the agronomy of root crops.* In Tai, E. A. et al., eds., *Proc. Int. Symp. Trop. Root Crops, Univ. West Indies, Section III, 1967, 1-17.*
- Hozyo, Y., Murata, T., and Yoshida, T. *The development of tuberous roots in grafting sweet potato plants, Ipomoea batatas Lam.* Bull. Nat. Inst. Agric. Sci. (Japan), Ser. D, No. 22, 1971, 165-191.
- Hozyo, Y., and Park, C. Y. *Plant production in grafting plants between wild type and improved variety in Ipomoea.* Bull. Nat. Inst. Agr. Sci. (Japan), Ser. D., No. 22, 1971, 145-164.
- Humphries, E. C. *The dependence of photosynthesis on carbohydrate sinks: current concepts.* In Tai, E. A. et al., eds., *Proc. Int. Symp. Trop. Root Crops, Univ. West Indies, Section II, 1967, 34-45.*
- Hunt, W. F. *Respiratory control and its prediction by a dynamic model of sugar beet growth.* Ph.D. thesis, Univ. Calif., Davis, 1974, 243 p.
- Jennings, D. L. *Cassava in Africa.* Field Crop Abs. 23, 1970, 271-278.
- Lemour, R., and Blad, B. L. *A critical review of light models for estimating the shortwave regime of plant canopies.* Agric. Meteorol. 14, 1974, 255-286.
- Leopold, A. C., and Kriedemann, P. E. *Plant growth and development.* McGraw-Hill, New York, 1975, 545 p.
- Liu, B. Y. H., and Jordan, C. *The interrelationship and characteristic distribution of direct, diffuse and total solar radiation.* Solar Energy, 4(3), 1960, 1-19.
- Lawrence, C. H., and Barker, W. G. *A study of tuberization in the potato, Solanum tuberosum.* Am. Potato J. 40, 1963, 349-356.
- Loomis, R. S., and Bennett, C. W. *Competitive relationships in virus-infested sugar beet fields.* J. Am. Soc. Sugar Beet Technol. 14, 1966, 218-231.
- Loomis, R. S., and Gerakis, P. A. *Productivity of agricultural ecosystems.* In Cooper, J. P., ed., *Photosynthesis and productivity in different environments.* Cambridge Univ. Press, Cambridge, U.K., 1975, 145-172.
- Loomis, R. S., Ng, E., and Hunt, W. F. *Dynamics of development in crop production systems.* In

- Burris, R. H., and Black, C. C., eds., *CO<sub>2</sub> metabolism and plant productivity*. Univ. Park Press, Baltimore, Md., 1976, 269–286.
- Loomis, R. S., and Torrey, J. G. *Chemical control of vascular cambium initiation in isolated radish roots*. Proc. Nat. Acad. Sci. 52, 1964, 3–11.
- Loomis, R. S., and Williams, W. A. *Productivity and the morphology of crop stands: patterns with leaves*. In Eastin, J. D., et al., eds., *Physiological aspects of crop yield*. Am. Soc. Agron. Madison, Wisc., 1969, 27–47.
- McCree, K. J. *An equation for the rate of respiration of white clover plants grown under controlled conditions*. In Setlik, I., ed., *Prediction and measurement of photosynthetic productivity*. PUDOC, Wageningen, The Netherlands, 1971, 221–229.
- The role of dark respiration in the carbon economy of a plant*. In Burris, R. H., and Black, C. C., eds., *CO<sub>2</sub> metabolism and plant productivity*. Univ. Park Press, Baltimore, Md., 1976, 177–184.
- Milford, G. F. J. *The growth and development of the storage root of sugar beet*. Ann. Appl. Biol. 75, 1973, 427–438.
- Milthorpe, F. L. *Some physiological principles determining the yield of root crops*. In Tai, E. A., et al., eds., *Proc. Int. Symp. Trop. Root Crops*, Univ. West Indies, Section II, 1967, 1–19.
- Mogilner, I., Portuguese, A. J. D., Gatuzyo, A. D., and Acosta, J. A. *Influence of Manihot flabellifolia as a scion on the formation of storage roots in M. esculenta as stock*. Bonplandia, 2, 1969, 137–142.
- Monsi, M., Uchijima, Z., and Oikawa, T. *Structure of foliage canopies and photosynthesis*. Ann. Rev. Ecol. Syst. 4, 1973, 301–327.
- Moorby, J., and Milthorpe, F. L. *Potato*. In Evans, L. T., ed., *Crop physiology*. Cambridge University Press, Cambridge, U.K., 1975, 225–257.
- Moser, B. C., and Hess, C. E. *The physiology of tuberous root development in dahlia*. Proc. Am. Soc. Hort. Sci. 93, 1968, 595–603.
- Neales, T. F., and Incoll, L. D. *The control of leaf photosynthesis rate by the level of assimilate concentration in the leaf: a review of the hypothesis*. Bot. Rev. 34, 1968, 107–125.
- Nitsch, J. P. *Existence d'un stimulus photoperiodique non spécifique capable de provoquer la tuberization chez Helianthus tuberosus L.* Bull. Soc. Bot. Fr. 112, 1965, 333–340.
- Perennation through seeds and other structures: fruit development*. In Steward, F. C., ed., *Plant physiology*, Vol. VIA, *Physiology of development*. Academic Press, New York, 1971, 413–501.
- Okigbo, B. N. *Effect of planting date on the yield and general performance of the cassava (Manihot utilisissima Pohl.)*. Nig. Agric. J. 8, 1971, 115–122.
- Palmer, C. E., and Smith, O. E. *Cytokinin-induced tuber formation on stolons of Solanum tuberosum L.* Physiol. Plant. 23, 1970, 599–606.
- Penning de Vries, F. W. T. *Substrate utilization and respiration in relation to growth and maintenance in higher plants*. Neth. J. Agric. Sci. 22, 1974, 40–44.
- Penning de Vries, F. W. T., Brunsting, A. H. M., and van Laar, H. H. *Products, requirements and efficiency of biosynthesis: a quantitative approach*. J. Theor. Biol. 45, 1974, 339–377.
- Peterson, L. W. *Control of cambial activity in roots of turnip (Brassica rapa)*. Can. J. Bot. 51, 1973, 475–480.
- Phillips, I. D. J. *Apical dominance*. Ann. Rev. Plant Physiol. 26, 1975, 341–367.
- Pirt, S. J. *The maintenance energy of bacteria in growing cultures*. Proc. Royal Soc. Lond. B. 163, 1965, 224–231.
- Radin, J. W. *Regulators of growth and development in roots of Raphanus sativus L.* Ph.D. thesis, Univ. Calif., Davis, 1970, 142 p.
- Radin, J. W., and Loomis, R. S. *Polar transport of kinetin in tissues of radish*. Plant Physiol. 53, 1974, 348–351.
- Railton, I. D., and Wareing, P. F. *Effects of day-length on endogenous gibberellins in leaves of Solanum indigena. I. Changes in levels of free acidic gibberellin-like substances*. Physiol. Plant. 28, 1973, 88–94.
- Schrader, L. *CO<sub>2</sub> metabolism and productivity in C<sub>3</sub> plants: an assessment*. In Burris, R. H., and Black, C. C., eds., *CO<sub>2</sub> metabolism and plant productivity*. Univ. Park Press, Baltimore, Md., 1976, 385–396.
- Shibles, R. M., and Weber, C. R. *Interception of solar radiation and dry matter production by various soybean planting patterns*. Crop Sci. 6, 1966, 55–59.
- Smith, J. H. C. *Products of photosynthesis*. In Franck, J., and Loomis, W. E., eds., *Photosynthesis in plants*. Iowa State Univ. Press, Ames, Iowa, 1949, Chapter 3.
- Thorne, G. N., and Evans, A. F. *Influence of tops and roots on net assimilation rate of sugar-beet and spinach beet and grafts between them*. Ann. Bot. 28, 1964, 499–508.
- Thorne, J. H., and Koller, H. R. *Influence of assimilate demand on photosynthesis, diffusive resistances, translocation, and carbohydrate levels of soybean leaves*. Plant Physiol. 54, 1974, 201–207.
- Tsuno, Y., and Fujise, K. *Studies on the dry matter production of sweet potato*. Bull. Nat. Inst. Agric. Sci. (Japan), Ser. D. No. 13, 1965, 131 p.
- Wallace, D. H., Peet, M. M., and Ozbun, J. L. *Studies of CO<sub>2</sub> metabolism in Phaseolus vulgaris L. and applications in breeding*. In Burris, R. H., and Black, C. C., eds., *CO<sub>2</sub> metabolism and plant productivity*. Univ. Park Press, Baltimore, Md., 1976, 43–58.

- Wardlaw, I. F. *Phloem transport: physical chemical or impossible*. *Ann. Rev. Plant Physiol.* 25, 1974, 515-539.
- Williams, C. N., and Ghazali, S. M. *Growth and productivity of tapioca (Manihot utilissima)*. I. *Leaf characteristics and yield*. *Expl. Agric.* 5, 1969, 183-194.
- Williams, W. A., Loomis, R. S., and Lepley, C. R. *Vegetative growth of corn as affected by population density*. I. *Components of growth, net assimilation rate and leaf-area index*. *Crop Sci.* 5, 1965, 215-219.
- Wilson, B. F. *Distribution of secondary thickening in tree root systems*. In Torrey, J. G., and Clarkson, D. T., eds., *The development and function of roots*. Acad. Press, London, 1975, 197-219.
- Wilson, L. A. *The use of rooted leaves and grafted plants for the study of carbohydrate metabolism in sweet potato*. In Tai, E. A., et al., eds., *Proc. Int. Symp. Trop. Root Crops*, Section II, 1967, 46-57.
- Winter, H. *Der Einfluss von Wirkstoffen, von Rontgen und Electronenstrahlen auf die Cambiumtatigkeit von Beta vulgaris*. *Planta*, 44, 1954, 636-668.

## Total Dry Matter Production, Tuber Yield, and Yield Components of Six Local Cassava Cultivars in Trinidad

E. B. Holmes and L. A. Wilson<sup>1</sup>

Dry matter production, quantitative shoot morphology, dry matter distribution, tuber yield, and yield components of six representative cassava cultivars in Trinidad are presented. The results are discussed in relation to the yield performance of elite cassava cultivars and the yield potential of the cassava species. A cassava type on which improvement of the yield potential of the species might be based is identified.

Cassava production in the Commonwealth Caribbean is estimated at  $26 \times 10^3$  t with an average productivity of 13.3 t/ha (7.8 tons/ha if the small but highly productive cassava in the Barbados is excluded). This level of cassava productivity is low compared with that in Brazil (14.6 t/ha), and cassava production represents only approximately 10% of the yam production of the region.

Cassava is grown in ecosystems ranging from the dry plains of Jamaica (annual rainfall 130 cm) to the very wet coastal plains of Guyana (annual rainfall 500 cm). However, despite the low productivity of Caribbean cassava, there have been reports of the existence of varieties with high yield potential (60 t/ha under experimental conditions). Similar productivity levels have been reported for elite cultivars in the CIAT cassava collection and a potential productivity level of 90 tons/ha/year has been predicted for the species by Cock (1974).

To increase Caribbean cassava production, two objectives must be achieved: (1) high productivity cultivars suitable for growth under the wide range of Caribbean ecosystems must

either be identified or synthesized; and (2) cultural practices calculated to optimize yield of high performance cultivars must be developed.

In pursuance of these objectives, total dry matter yield, tuber yield, and other components of selected cultivars have been analyzed to study crop performance in cassava cultivars with contrasting growth habits. This was done prior to introduction of exotic germ plasm and regional testing of selected high performance types in different Caribbean ecosystems. Preliminary data on six representative cultivars are presented to place these cultivars in the profile of tuber yield productivity levels.

### Materials and Methods

Six cultivars (*Manihot esculenta* Crantz) were grown on 30-cm-high ridges that were 90 cm apart. Stem cuttings (18 cm, 85 g) were planted 90 cm apart at an angle of 45° along the crest of the ridge and were each treated with 140 g of a standard 12:12:7 NPK fertilizer one month after planting. The experiment was established as a randomized split plot design with three replicates, as an out of season crop planted in the dry season on 10 January 1974. One week after shoot emergence selected

<sup>1</sup>Department of Crop Science, University of the West Indies, St Augustine, Trinidad.

- Wardlaw, I. F. *Phloem transport: physical chemical or impossible*. *Ann. Rev. Plant Physiol.* 25, 1974, 515-539.
- Williams, C. N., and Ghazali, S. M. *Growth and productivity of tapioca (Manihot utilissima)*. I. *Leaf characteristics and yield*. *Expl. Agric.* 5, 1969, 183-194.
- Williams, W. A., Loomis, R. S., and Lepley, C. R. *Vegetative growth of corn as affected by population density*. I. *Components of growth, net assimilation rate and leaf-area index*. *Crop Sci.* 5, 1965, 215-219.
- Wilson, B. F. *Distribution of secondary thickening in tree root systems*. In Torrey, J. G., and Clarkson, D. T., eds., *The development and function of roots*. Acad. Press, London, 1975, 197-219.
- Wilson, L. A. *The use of rooted leaves and grafted plants for the study of carbohydrate metabolism in sweet potato*. In Tai, E. A., et al., eds., *Proc. Int. Symp. Trop. Root Crops, Section II*, 1967, 46-57.
- Winter, H. *Der Einfluss von Wirkstoffen, von Rontgen und Electronenstrahlen auf die Cambiumtatigkeit von Beta vulgaris*. *Planta*, 44, 1954, 636-668.

## Total Dry Matter Production, Tuber Yield, and Yield Components of Six Local Cassava Cultivars in Trinidad

E. B. Holmes and L. A. Wilson<sup>1</sup>

Dry matter production, quantitative shoot morphology, dry matter distribution, tuber yield, and yield components of six representative cassava cultivars in Trinidad are presented. The results are discussed in relation to the yield performance of elite cassava cultivars and the yield potential of the cassava species. A cassava type on which improvement of the yield potential of the species might be based is identified.

Cassava production in the Commonwealth Caribbean is estimated at  $26 \times 10^3$  t with an average productivity of 13.3 t/ha (7.8 tons/ha if the small but highly productive cassava in the Barbados is excluded). This level of cassava productivity is low compared with that in Brazil (14.6 t/ha), and cassava production represents only approximately 10% of the yam production of the region.

Cassava is grown in ecosystems ranging from the dry plains of Jamaica (annual rainfall 130 cm) to the very wet coastal plains of Guyana (annual rainfall 500 cm). However, despite the low productivity of Caribbean cassava, there have been reports of the existence of varieties with high yield potential (60 t/ha under experimental conditions). Similar productivity levels have been reported for elite cultivars in the CIAT cassava collection and a potential productivity level of 90 tons/ha/year has been predicted for the species by Cock (1974).

To increase Caribbean cassava production, two objectives must be achieved: (1) high productivity cultivars suitable for growth under the wide range of Caribbean ecosystems must

either be identified or synthesized; and (2) cultural practices calculated to optimize yield of high performance cultivars must be developed.

In pursuance of these objectives, total dry matter yield, tuber yield, and other components of selected cultivars have been analyzed to study crop performance in cassava cultivars with contrasting growth habits. This was done prior to introduction of exotic germ plasm and regional testing of selected high performance types in different Caribbean ecosystems. Preliminary data on six representative cultivars are presented to place these cultivars in the profile of tuber yield productivity levels.

### Materials and Methods

Six cultivars (*Manihot esculenta* Crantz) were grown on 30-cm-high ridges that were 90 cm apart. Stem cuttings (18 cm, 85 g) were planted 90 cm apart at an angle of 45° along the crest of the ridge and were each treated with 140 g of a standard 12:12:7 NPK fertilizer one month after planting. The experiment was established as a randomized split plot design with three replicates, as an out of season crop planted in the dry season on 10 January 1974. One week after shoot emergence selected

<sup>1</sup>Department of Crop Science, University of the West Indies, St Augustine, Trinidad.

Table 1. Total dry matter production and quantitative stem morphology of six cassava cultivars.<sup>a</sup>

	Dry matter production				Stem D. wt. /plant	Branch No. /plant	Stem D. wt. /branch	Node No. / branch /plant
	g/plant	g/plant /week	t/ha	t/ha /week				
Redstick	3189	69.3	38.3 <sup>b</sup>	0.83	1522	29.7	51.2	40.1
Whitestick II	3036	66.0	36.4	0.79	1553	24.5	63.4	45.1
Whitestick I	2997	65.0	36.0	0.78	1698	19.2	88.4	58.8
Maracas Blackstick	1885	41.0	22.6	0.49	645	16.7	38.6	36.3
Around the World	1664	36.2	20.0	0.43	961	34.3	28.0	35.0
Pie Pip	1424	31.0	17.1	0.37	638	30.5	20.9	32.0
Mean	2366	51.4	28.4	0.62	1170	25.8	45.3	40.0
S.E.	477.7	—	—	—	242.3	6.8	—	6.0

<sup>a</sup>Predicted dry matter production rates reported by or calculated from different authors: 46 tons/ha/year (Cock 1974); 73 tons/ha/year calculated from de Witt (1967); and 130 tons/ha/year calculated from Loomis and Williams (1963).

<sup>b</sup>43 tons/ha/year.

plants in each replicate were pruned to one shoot and the single shoot condition was maintained during crop growth. After 46 weeks of growth, the crop (15 plants per cultivar) was harvested and total dry matter, dry matter distribution, parameters of shoot morphology, tuber yields, and the components of yield, tuber number, and mean tuber weight were recorded and evaluated by analysis of variance and by correlation and regression analysis.

## Results and Discussion

### Total Dry Matter Production

The six cassava cultivars studied could be classified into high (3000 g/plant) and low (1400–1900 g/plant) dry matter producing types (Table 1). The average rate of dry matter production of the former types (42 tons/ha/year) was similar to the production rate predicted by Cock (1974) for cassava, was 58% of the rate (73 t/ha/year) predicted by de Wit (1967) for *Solanum* potatoes, but only 32% of the 130 t/ha/year production level based on calculations of maximum photosynthetic productivity by Loomis and Williams (1963) for maize.

### Quantitative Shoot Morphology

Numbers of leaves produced over the crop growth period, as assessed by total node numbers, were high (975–1231) in all cultivars except Maracas Blackstick (607). Percentage leaf fall was similar (52.5–59.9%) in all cultivars leading to proportionality between total

leaf number and the number of leaves (289–585) retained at final harvest. Cultivars could, however, be separated into three groups on the basis of leaf area. Thus, there were high (Redstick and Whitestick II, 7.1–7.9 dm<sup>2</sup>), intermediate (Whitestick I and Pie Pip, 4.5–5.3 dm<sup>2</sup>), and low (Maracas Blackstick and Around the World, 2.6–2.7 dm<sup>2</sup>) leaf area cultivars. Low leaf areas were due to low leaf number (289) and low average area leaf (46.2 cm<sup>2</sup>) in Maracas Blackstick and Around the World, respectively. The high dry matter producing types Redstick, Whitestick I and II as well as the low dry matter type Maracas Blackstick were broad leaf cultivars with leaves containing 3–9 elliptically shaped leaf lobes with length/breadth ratios of 3–4. Around the World and Pie Pip were fine leaf cultivars with leaf lobes having length/breadth ratios of 12–15.

There were no obvious relationships between stem length, branch length, and internode length and total dry matter production. The cultivar separation into three high (1522–1698 g/plant) and three low (645–961 g/plant) yielding types on the basis of stem dry weight (Table 1) was similar to the total dry matter separation, indicating a measure of proportionality between stem dry weight and total dry weight. However, both in the high and low yielding groups, there were cultivars with lower branch numbers per plant (Whitestick I, 19.2 and Maracas Blackstick, 16.7) than the remaining cultivars (24.5–34.3), leading to heavier stem dry weight per branch in these

Table 2. Distribution of dry matter in six cassava cultivars.

	Dry matter distribution (% TDM)					Planting stick
	Stem	Petiole	Lamina	Tuber	Thick root	
Redstick	47.0	1.79	8.80	34.3	0.70	7.23
Whitestick II	48.3	2.19	8.50	35.6	0.67	4.68
Whitestick I	56.1	1.88	6.88	29.4	0.84	4.85
Maracas Blackstick	34.7	1.62	5.67	52.5	0.61	4.79
Around the World	57.6	1.46	8.36	25.0	1.10	6.50
Pie Pip	44.4	1.48	9.80	36.4	1.10	6.78
Mean	48.1	1.70	8.00	35.6	0.84	5.80

cultivars (88.4 and 38.6, respectively) when compared with the other two in the yield group. Whitestick I also had higher node number per branch (58.8) than the remaining cultivars (32.0–45.1). Apart from Whitestick I, the relatively small differences between values for node numbers per branch in the different cultivars (Table 1) suggested that leaf number could be increased in the cultivars studied by increasing branch number, especially as percentage leaf fall values were also constant.

### Interrelationships

There were significant correlation coefficients between node number ( $r = 0.64$ ), leaf number ( $r = 0.56$ ), leaf area ( $r = 0.69$ ), and total dry weight over all cultivars. For individual cultivars, correlation coefficients between node number and total dry weight were high ( $r = 0.84$ – $0.90$ ) in all cultivars except Whitestick I and II ( $r = 0.59$  and  $0.69$ , respectively). The leaf number correlation coefficients were also high in all cultivars except in Whitestick II and for leaf area, correlation coefficients were significant for all cultivars except Pie Pip. Total number of leaves produced was important for total dry matter production. In individual cultivars, leaf number is directly proportional to leaf area, and dry matter production is a function of photosynthesis of the leaf surface. Over the six cultivars, the low dry matter production of the fine leaf varieties (e.g. Around the World) despite their high leaf production may be explained by low leaf area (and hence low total photosynthesis). However, flowering, profuse branching, and a high percentage of recently produced young leaves at harvest may also be responsible for the low dry matter production of Pie Pip.

### Distribution of Dry Matter

The distribution of dry matter between the tubers and other organs of the plants was also calculated. Dry matter distribution to tubers (harvest index) was low (25.0–36.4%) in all cultivars except Maracas Blackstick (52.5%) and there was correspondingly high dry matter distribution to stems in these cultivars (44.4–57.6%) and low distribution (34.7%) in Maracas Blackstick. However, even in this cultivar, harvest index was relatively low compared with values of up to 70% reported for the species (CIAT 1974).

On the basis of dry matter production and distribution patterns, the six cultivars studied might be classified as follows: (1) high dry matter production/low harvest index types — Redstick, Whitestick I, and Whitestick II; (2) low dry matter production/high harvest index type — Maracas Blackstick; and (3) low dry matter production/low harvest index types — Around the World, and Pie Pip.

### Cultivar Yields and Yield Components

Tuber yields (Table 2) were low compared with those of elite cassava cultivars (CIAT 1974). However, four of the six cultivars studied were comparatively high yielding (29.5–31.9 t/ha) and the remaining two were low yielding (14.3 and 16.6 t/ha). The higher yielding cultivars had lower yield variability (C.V. 34–39%) than the low yielding cultivars (41–69%) confirming earlier work by Haynes and Wholey (1971), Lowe and Wilson (1975b), and Wilson (1975), which suggested that high yield variability was one of the contributing factors to low yield in tropical root crops. Thus, if the highest yield per plant recorded (4183 g) were consistently maintained over the experiment the yield productivity of

Table 3. Tuber yield of six cassava cultivars.

	Tuber yield			Tuber No.		Mean tuber wt.	
	t/ha	g/plant	CV(%)	No./plant	CV(%)	g/plant	CV(%)
Redstick	31.2	2600	39	7.1	25	409	55
Whitestick II	31.9	2660	34	4.8	25	591	45
Whitestick I	27.9	2327	38	7.1	39	340	41
Maracas Blackstick	29.5	2467	36	6.1	39	430	37
Around the World	14.3	1191	69	4.2	46	272	56
Pie Pip	16.6	1383	41	3.4	41	452	44
Mean	25.2	2105	37	5.4	33	416	50

the crop would have been 57.8 t/ha or 65 t/ha/year.

Tuber numbers per plant (3.4–7.1) (Table 3) were very low compared with data previously recorded for other cassava varieties (10–12 tubers per plant). Mean tuber weights (272–591 g/plant) were however greater than those recorded by Enyi (1972) (253–297) and Williams (1974) (229–381). It appears that low tuber number was the more important contributing component to the low tuber yield in the cassava cultivars studied.

Variabilities in yield components were greater for mean tuber weight than for tuber number, and mean tuber weight was the more important immediate source of yield variation in all cultivars except Maracas Blackstick. Variabilities in each component contributed significantly and independently to yield variability and together accounted for 76–97% of the total variation in tuber yield.

If it is assumed that the major source of yield variation is the competition pressure that develops in the crop community in the course of the crop growth cycle, and that yield variability leads to reduced yield, then individual mean tuber weight values reflected pressure from this source to a greater extent than tuber number. It is concluded, therefore, that despite the low tuber number values recorded for the varieties studied, tuber number variability did not originate principally from competition pressure in the crop community. It is however difficult to determine from results of the current experiments whether low tuber number was a genetic characteristic of the cultivars or was a reflection of the environment in which the crop was cultivated, e.g. dry conditions during early growth. Nevertheless, the importance of mean tuber weight as a major source of yield variability is in agreement with data previously published for sweet potato and yam.

Williams (1974) also concluded that tuber size was the major component of yield in cassava.

### Interrelationships between Yield Components and Yield

There were significant negative correlation coefficients between tuber number and mean tuber weight in the two high yielding cultivars (Redstick, Whitestick II) and also in the low yielding cultivar, Pie Pip, at the  $p = 5\%$  level. This level of yield component compensation was less than that recorded for sweet potato by Lowe and Wilson (1975a) and the regressions of tuber number on mean tuber weight accounted for 25–30% of the yield variation. However, the significant negative regression of tuber number on mean tuber weight for the four high yielding cultivars suggested that mean tuber weight/tuber number ratios might be cultivar characteristics. Since no such correlation could be demonstrated for the two low yielding cultivars, it is suggested either that the high yielding cultivars might be representatives of a distinct line with yield component compensation at the genetic level, or that there was not sufficient competition pressure in the population of the low yielding cultivars to develop strong compensatory relationships between the components of tuber yield. Yield component compensation partially overcame the effects of low tuber number on yield in Whitestick II and Pie Pip within the high and low yield level groups, respectively. Similar compensatory relationships did not result in raising the yield level of the high yielding cultivars to that recorded in elite representatives of the species (60 t/ha).

Significant correlation coefficients between either yield component and yield suggested that cultivars might be classified according to the contribution of yield components to yield

as follows: (1) tuber number/tuber weight types in which both components were significantly correlated with yield — Around the World; (2) tuber weight types in which tuber weight was significantly correlated with yield — Whitestick I, Whitestick II, Redstick, and Pie Pip; and (3) tuber number type where tuber number was significantly correlated with yield — Maracas Blackstick.

### Leaf Production

The significant correlations demonstrated between parameters of leaf production — node number, leaf number, and leaf area — and total dry weight were also established between these parameters and tuber yield, indicating that leaf production and leaf abscission were important determinants both of total dry matter production and tuber yield. Correlation coefficients were, however, higher with total dry matter than with tuber yield. Similar correlations between leaf number, node number, and cassava yield have also been demonstrated by others. Variation in node number and leaf number within the six cultivars studied explained more than 50% of the variability in tuber yield except in Whitestick I and II (40–48%). When all cultivars were considered together leaf number and node number accounted for less than 25% of the tuber yield variability. Thus, although high leaf production and leaf retention were important for high yield within individual cultivars, it would appear that high yield was not necessarily correlated with high rates of leaf production. The yield performance of Maracas Blackstick demonstrated that high yields could be achieved with a low leaf production cultivar provided that high harvest indices are realized.

### Harvest Index

Although there were no significant correlations between tuber yield and harvest index in the four high yielding cultivars, such correlations were significant both for the low-yielding cultivars ( $p = 0.05$  and  $0.10$ ) and for all cultivars ( $p = 0.001$ ). The former correlation was interpreted to mean that plant to plant variation in harvest indices may have been partly responsible for the high yield variability in low yielding cultivars (Table 3). The latter correlation indicated that harvest indices might

be used as a means of assessing the yield potential of a collection of cultivars grown under similar conditions as was previously suggested at CIAT (CIAT 1974).

This work was done as part of a research program on root crops supported by an International Development Research Centre (IDRC) grant to the Faculty of Agriculture, University of the West Indies, St. Augustine, Trinidad. A research grant from the Inter-University Council for Higher Education Overseas (U.K.) to one of us (E. B. Holmes) is gratefully acknowledged and we wish to thank A. Ragoobarsingh, A. Whitehall, and R. Sookradge for technical assistance as well as Miss G. Mitchell for typing.

CIAT. *Cassava production systems*. Annual Report, CIAT, 1974, 54–108.

Cock, J. H. *Agronomic potential for cassava*. In Araullo, E. V., Nestel, B., and Campbell, M., eds., *Cassava processing and storage*. International Development Research Centre, Ottawa, IDRC-031 e, 1974, 21–26.

De Wit, C. T. *Photosynthesis: its relationship to over-population*. In San Pietro, A., Greer, F. A., and Army, T. J., eds., *Harvesting the sun*. Academic Press, New York, London, 1967.

Enyi, B. A. C. *Effect of shoot number and time of planting on growth and development and yield of cassava (Manihot esculenta Crantz.)* J. Hort. Sci. 47, 1972, 457–466.

Haynes, P. H., and Wholey, D. W. *Variability in commercial sweet potatoes (Ipomoea batatas L. Lam) in Trinidad*. Expt. Agric. 7, 1971, 27–32.

Loomis, R. S., and Williams, W. A. *Maximum crop productivity: An estimate*. Crop Science 3, 1963, 67–72.

Lowe, S. B., and Wilson, L. A. *Yield and yield components of six sweet potato (Ipomoea batatas) cultivars. I Contribution of yield components to tuber yield*. Expt. Agric. 11, 1975a, 39–48.

*Yield and yield components of six sweet potato (Ipomoea batatas) cultivars. II Variability and possible sources of variation*. Expt. Agric. 11, 1975b, 49–58.

Williams, C. N. *Growth and productivity of tapioca (Manihot utilissima) IV. Development and yield of tubers*. Expt. Agric. 10, 1974, 9–16.

Wilson, L. A. *Some determinants of yield in tropical root crops with particular reference to sweet potato*. Presented at the Regional Meeting on the Production of Root Crops, Suva, Fiji, November 1975.

## Effect of Soil Compaction on Leaf Number and Area, and Tuber Yield of White Lisbon Yam

Theodore U. Ferguson and Frank A. Gumbs<sup>1</sup>

The effect of soil compaction in root and tuber zones on the growth and yield of White Lisbon yams (*Dioscorea alata* L.) was examined using specially designed boxes. Soil compaction reduced leaf number, leaf area, and yield. A close positive linear relationship was observed between leaf number and yield. It is suggested that the growing tuber contributes substantially to the development of the plant by assisting in the absorption of moisture and essential nutrients. Compaction in the tuber zone had no effect on tuber number, tuber length, and tuber width. However, tubers growing in compacted soil penetrated the soil to a lesser depth, tended to develop above the original level of the soil to a greater extent, and had a larger number of growing points (or toes).

The edible portion of the yam (*Dioscorea* spp.) is the underground tuber. Tubers can be very large, and sometimes weigh more than 80 kg. In commercial production, however, tubers are usually very much smaller and range from less than 1 kg to about 10 kg depending on cultivar and growing conditions. White Lisbon (*D. alata* L.) is the major cultivar of Trinidad, Barbados, and other islands in the Eastern Caribbean; it normally produces tubers of 1–5 kg in weight. It is the object of this study to examine the relative effect of soil compaction in root and tuber zones on growth and yield of the White Lisbon yam.

### Methods

The yams were grown in specially designed boxes (Fig. 1) in which the tubers and roots of the same plant developed in different compartments. Each compartment was 55.9 cm high, 22.9 cm wide, and 61.0 cm long. The partitions between the root and tuber compartments were about 5 cm lower than the outer edge of the box. The boxes were constructed from 2.5 cm thick wood.

There were six treatments in a 2 × 3 factorial with four replications. The initial bulk densities of the soil in the root and tuber compartments for each of the treatments are given in Table 1. A plot consisted of a single box in which one plant was grown.

The experiment was conducted at the University Field Station, Valsayn, Trinidad and the soil, classified as Fluventic Eutropepts by Smith (1974), was the River Estate Loam

Table 1. Initial bulk densities (g/cm<sup>3</sup>) in the tuber and root compartments.

Treatment code	Bulk densities	
	Tuber compartment	Root compartment
11	1.1	1.1
12	1.1	1.3
21	1.3	1.1
22	1.3	1.3
13	1.1	1.6
23	1.3	1.6

(coarse sand 5%, fine sand 45%, silt 23%, clay 26%, and organic matter 1% oven dry weight). The boxes were placed in the field and then packed with topsoil to the required bulk density ( $D_b$ ). The soil was taken from the top 30 cm and sieved through a 6.3 mm mesh and then allowed to dry to about 10% moisture before packing in the boxes. The soil required no compaction to achieve a  $D_b$  of 1.1 g/cm<sup>3</sup>; this was therefore the lowest possible  $D_b$  for this soil under existing conditions. To achieve a  $D_b$  of 1.3 g/cm<sup>3</sup> the soil was compacted in 8 cm depth intervals by packing the calculated weight of soil to the required depth with a broad wooden hammer, and for a  $D_b$  of 1.6 g/cm<sup>3</sup> the packing was done for an additional 4 cm of soil. All boxes were filled to about 5 cm below the upper edge of the box, and therefore, to the top of the partitions separating the root and tuber compartments.

Black plastic (2 mm gauge) was doubled and placed on top of the soil in the tuber (or middle) compartment with about 10 cm of plastic overhanging on one side of the box as illustrated in Fig. 1. The overhang of plastic was necessary to facilitate the removal of the

<sup>1</sup>Caribbean Development Bank, P.O. Box 408, Wilkey, St. Michael, Barbados, and Department of Soil Science, University of the West Indies, St. Augustine, Trinidad, respectively.

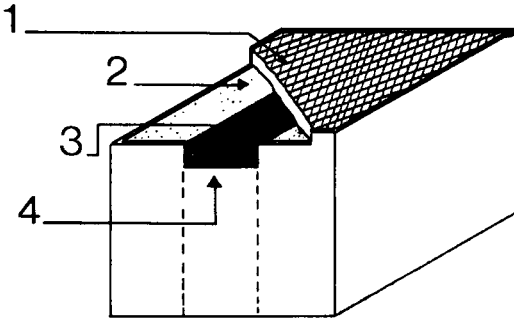

Fig. 1. Cut-away of upper 5 cm of soil to show the position of the plastic: (1) loose soil; (2) compact/uncompacted soil of root compartment; (3) black plastic over tuber compartment; and (4) black plastic overhang.

plastic at a later stage. The plastic was 8 cm wider than the middle compartment; 4 cm on each side was folded over the separating partitions to prevent roots from entering the tuber compartment. A 5 cm depth of loose soil was added to bring the soil in all three compartments to the level of the outer edge of the box.

Head sets of White Lisbon yam (*D. alata* L.), each weighing 100 g, were planted in the centre of the tuber compartments on 27 July 1973. The sets were buried to a depth of about 2 cm in the centre of the middle compartment. The soil in all three compartments was lightly mulched with dry grass after planting. Mulching was considered necessary to prevent crusting of the soil surface. Compound fertilizer having a N:P:K ratio of 13:13:20 was applied at the rate of 24 g per compartment in a split dose. The plants were staked.

The number of leaves per plant (i.e. per plot) was recorded 3, 4, 8, and 25 weeks after planting. Leaf area was estimated at 25 weeks after planting. The bulk density was measured area, 15 leaves were selected randomly from each plant at 25 weeks and the overall length ( $B$ ) was measured. The area of these leaves was then calculated using the formula: leaf area =  $-76.3 + 10.0B$ . The area of the whole plant was then determined, by multiplying the area per leaf by the total number of leaves per plant.

Bulk density of the top 38 cm of soil and average root density were determined 27 weeks after planting. The bulk density was measured by extracting a column of soil 38 cm long in a 5 cm diameter open slot tube sampler. The

soil sections were removed, dried at 105 °C, and weighed. Bulk density was calculated as grams of dry soil per cubic centimetre. Root density was measured by taking six soil samples to a depth of 38 cm from each root compartment with the 5 cm diameter tuber sampler. Five samples were taken from the apices of an imaginary five-pointed star and the sixth from the centre of the star. Each sample was cut into 12.7 cm lengths and the six samples from each depth bulked. The soil was carefully washed from the roots on a muslin cloth sieve and the roots collected and dried at 70 °C.

The tubers were harvested on 12 February 1974, 28 weeks after planting. Data were recorded on tuber number, tuber weight, length and width of tubers, maximum depth of tubers, and the number of growing points (i.e. the number of fingers or toes). Bulk densities of the soil at the base of the tubers were measured on core samples 5 cm in diameter and 7.5 cm long, sampled by the procedure described by Blake (1965).

## Results

All the main roots were confined to the root compartments indicating that the system effectively separated the roots from the tuber compartments. Tubers had a large number of fine roots (tuber roots) on their surface. These were thicker and present in greater quantities at the head than at the tail of the tubers.

Slightly higher bulk densities were recorded in the compacted tuber compartments 1 week before harvesting, but differences were not significant. The bulk densities of the soil at the base of tubers were very much higher than the initial bulk densities, indicating that the tuber itself was compacting the soil. This trend was particularly marked at compaction level 1 (1.1 g/cm<sup>3</sup>). In the root compartment the mean bulk density of the top 38 cm of soil at compaction level 3 ( $D_b = 1.38$  g/cm<sup>3</sup>) was significantly higher than compaction levels 1 and 2 but very much lower than the initial bulk density of 1.6 g/cm<sup>3</sup>. In both the root and tuber compartments the  $D_b$  of the soil at level 1 increased up to 1 week before harvesting.

Yield per plant decreased significantly with increase in initial bulk density of both the root and tuber compartments (Fig. 2). Differences in yield are shown in Table 2. The interaction between compaction levels in the root and tuber compartments was significant. Yield was

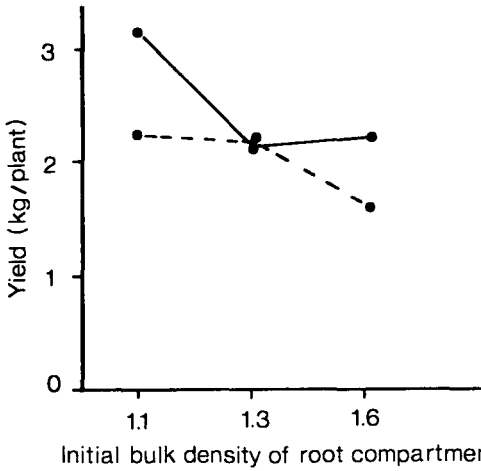

Fig. 2. Effect of initial bulk density in root and tuber compartments on yield: — initial  $D_b$  of tuber compartment = 1.1; ---- initial  $D_b$  of tuber compartment = 1.3.

highest (3.09 kg/plant) in the treatment (11) where the soil was not compacted in either the root or tuber compartment, and lowest (1.60 kg/plant) in the treatment (23) having the highest compaction level. Compaction to level 2 in the tuber compartment, with the root compartments at level 1, reduced yield by 27%, whereas compaction to level 2 in the root compartments with the tuber compartment at level 1, reduced yield by 32%.

There were no significant differences in tuber numbers per plant among treatments. The decrease in yield with increase in soil compaction in the root and tuber compartments was therefore due mainly to a decrease in tuber

size. There were no significant differences in the number of growing points of tubers as a result of varying levels of compaction in the root and tuber compartments, but tubers from the higher compaction level 2 of the tuber compartment tended to have a higher number of growing points (12.7/plant) than those from low compaction level 1 (8.7/plant).

Soil compaction in the tuber compartment had no significant effect on tuber length or tuber width. There is some indication, however, that compaction resulted in slightly shorter and broader tubers, and these therefore had a lower length to width ratio than tubers grown in the soil that was not compacted. Tubers grown in soil that was not compacted penetrated the soil to a greater depth than those grown in compacted soil. Tubers in the more compacted soil tended to grow upwards above the level of the box more than tubers in which the soil was not compacted. Mounding at the base of the plants, especially in compacted tuber compartments was very evident at harvesting. Tubers in the compacted tuber compartments (level 2) had a mean height of 18 cm above the top of the box compared to 11 cm for those with the lower compaction level 1.

Soil compaction in the tuber compartment had no effect on leaf number per plant at 3, 4, and 8 weeks after planting (Table 3). However, compacting the soil in the root compartment significantly reduced the number of leaves per plant at 3, 4, and 8 weeks. Leaf number at 25 weeks was significantly reduced by compaction in both the root and tuber compartments. Estimated leaf area at 25 weeks was

Table 2. The effect of soil compaction levels in root and tuber compartments on tuber yield (kg/plant), percentage reduction given in parentheses.

		Root compartment (RC)			
		1	2	3	Mean
Tuber compartment (TC)	1	3.09 (0)	2.11 (32)	2.21 (29)	2.47 (0)
	2	2.26 (27)	2.17 (30)	1.60 (48)	2.01 (19)
	Mean	2.67 (0)	2.14 (20)	1.90 (29)	—
		S.E.			<i>p</i>
Mean tuber compartments (TC)		0.15			0.018
Mean root compartments (RC)		0.12			0.007
TC × RC		0.21			0.125
C.V.					18.9%

Table 3. The effect of soil compaction in root and tuber compartments on leaf number per plant at 3, 4, 8, and 25 weeks after planting and on estimated leaf area per plant at 25 weeks after planting.

Compartment	Compaction level	Leaf number				Leaf area at 25 wks (cm <sup>2</sup> × 10 <sup>3</sup> )
		3 wks	4 wks	8 wks	25 wks	
Root	1	7.5	16.7	90.2	207.5	11.31
	2	4.4	11.1	67.5	185.7	10.32
	3	5.2	12.9	73.5	171.2	8.85
	S.E. ±	1.1	1.8	7.7	9.7	0.97
Tuber	1	5.1	12.7	80.7	203.8	10.97
	2	6.3	14.5	73.5	172.5	9.36
	S.E. ±	0.9	1.4	6.3	7.9	0.79

also reduced by compaction in both root and tuber compartments, but differences were not as significant.

A very highly significant correlation coefficient of +0.796 ( $p = 0.001$ ) was observed between leaf number at 25 weeks and yield ( $y = -0.183 + 0.0129 \ln$ ).

No significant differences in average root densities in the root compartments were measured among treatments.

### Discussion

Soil compaction in both the root and tuber compartments decreased tuber yield. Significant positive correlations were observed between leaf number at 25 weeks and yield and leaf area at 25 weeks and yield. Lower yields at the higher compaction levels therefore seem to be related to a reduction in the total photosynthetic surface and thus the total amount of carbohydrate available to the developing tubers.

The absence of any effect of soil compaction in the tuber compartments on leaf number between 3 and 8 weeks is not surprising because during that time the tubers (really only primary nodal complexes (Ferguson 1973) are present at this early stage of growth) were not in contact with the soil of differing compaction levels. The black plastic, which was removed at 9 weeks, separated the tubers from the underlying compacted or uncompacted soil. The large effect of compaction in the tuber compartment on leaf number and leaf area at 25 weeks indicates that the growing tuber may contribute substantially to the promotion of growth of the plant. The tuber is likely to be absorbing nutrients and moisture through the

numerous roots that occur on the tubers, and which are more prevalent during the early period of tuber bulking. The tuber surface itself may also be absorbing nutrients and moisture. It has been observed that fibrous root (mostly nontuber) development reached a peak at 4 months after planting and declined thereafter, suggesting a reduced potential for the absorption of nutrients after 4 months (James 1953). The evidence here suggests that the tuber through its surface and/or the many fine roots on the surface may help to offset the reduced potential for absorption of nutrients and moisture resulting from the decline in the fibrous root system. The tuber itself, therefore, may be playing a major role in providing essential nutrients and moisture for plant growth.

The finding that the tuber may play an important role in the nutrition of the yam plant is considered significant. It may help to explain the dramatic effect the application of organic fertilizer has on increasing the yield of yams (Ferguson and Haynes 1970). Organic fertilizers when incorporated into the hill or ridge would provide not only a soil medium offering relatively low resistance to the development of tubers but also nutrients in the immediate vicinity of tubers. The effect of placement of fertilizer in the vicinity of the developing tuber on growth and yield of yams is worth investigating.

Tubers from the less compacted treatments presumably met with less resistance and penetrated the soil to a greater depth. They therefore had the opportunity of exploiting a greater volume of soil for nutrients and moisture, which may have resulted in better growth and thus higher leaf numbers. Tubers developing in the more compacted soil may also be smaller

sinks for carbohydrates because the soil offered greater resistance to their growth and thus led to a build up of assimilates in the translocatory system and eventually at the sites of photosynthesis. It has been shown that photosynthesis can be inhibited by an excess of assimilation products (Humphries 1967; Neals and Incoll 1968). Reduced photosynthesis results in a smaller amount of assimilates being available for plant growth and thus results in smaller plants.

The results also suggest that the normal geotropic growth of tubers was restricted by the resistance offered by the soil in the compacted tuber compartments. Although they were smaller, tubers from compacted compartments grew higher above the top of the box than tubers from compartments that were not compacted. The slightly lower length to width ratio also suggests that tubers have the tendency to expand laterally in compacted soil. Tubers from the more compacted tuber compartments also had a slightly greater number of growing points or "toes." It is well known that soil resistance can be reduced by the incorporation of organic matter and many farmers in the Caribbean claim that tubers of White Lisbon yams develop fewer "toes" when produced in soils to which organic matter is added.

Compaction in the root compartment reduces tuber yield seemingly through a reduction of leaf numbers and leaf areas from as early as 3 weeks in the highest level of compaction. Reductions of leaf growth and tuber yield in treatments with compacted root compartments were likely to be due to the failure of roots to penetrate and exploit the soil volume for nutrients and moisture. Reduced aeration, less available water capacity, and slower soil water conductivity may also be important limiting factors.

It is not surprising that bulk densities in the tuber compartment at harvest were higher than bulk densities in the root compartment because tubers, in expanding during development,

would exert physical pressure to the surrounding soil mass, resulting in increased bulk densities. The bulk densities of the soil at the base of the tubers were higher than either of the two initial bulk densities indicating that the tuber itself was compacting the soil during its growth. The ability of the soil to deform under stress may therefore be an important factor affecting the yield of yams.

The writers wish to acknowledge with thanks the valuable help given by Mr Clifton Charles and Mr Clyde Pilgrim in the conduct of this experiment. The assistance of all other individuals who helped in the field and laboratory is also acknowledged. In addition, we would like to thank Mr Graham Taylor of the Biometrics Unit for assisting with the analysis of the data and Mrs Vernese Clarke for typing.

- Blake, G. R. *Bulk density*. In *Methods of Soil Analysis*, Part 1. American Society of Agronomy, Wisconsin, USA, 1965.
- Ferguson, T. U. *The effect of sett characteristics and spacing on growth, development and yield of yams (Dioscorea spp.)*. Ph.D. thesis, University of the West Indies Library, St. Augustine, Trinidad, 1973.
- Ferguson, T. U., and Haynes, P. H. *The response of yams (Dioscorea spp.) to nitrogen, phosphorus, potassium, and organic fertilizers*. Proc. 2nd Int. Symp. Trop. Root Crops, 1, 1970, 93.
- Humphries, E. C. *The dependence of photosynthesis on carbohydrate sinks: current concepts*. Proc. 1st Int. Symp. Trop. Root Crops, Section II, 1967, 34-45.
- James, L. J. *Study of the growth and development of yams — Dioscorea alata Linn — in relation to planting methods*. AICTA Thesis, University of the West Indies Library, St. Augustine, Trinidad, 1953.
- Neals, T. C., and Incoll, L. D. *The control of leaf photosynthesis rate by the level of assimilate concentration in the leaf. A review of the hypothesis*. Bot. Rev. 34, 1968, 107.
- Smith, G. D. *Study of the correlation of the soils of the former British territories in the West Indies*. Department of Soil Science, University of the West Indies, Trinidad, 1974.

## The Mukibat System of Cassava Production

T. S. Dharmaputra and G. H. de Bruijn<sup>1</sup>

The Mukibat system may outyield normal cassava production systems. Individual varieties react differently to the system, therefore it may be possible to select for high yielding varieties that have good eating quality, but which only produce moderately under the normal system.

The highest accumulation of dry matter in the root of the Mukibat cassava occurred between 12 and 15 months in all three varieties tested (it was not necessary to make planting holes for the Mukibat system). Nitrogen was the limiting plant nutrient at one location.

Scion material taken from the Mukibat plants was found to be as good as that taken from the original *M. glaziovii* tree. Two different types of scion were tested: the so called "black" type was superior to the "white" type at one location, but not at the other.

The Mukibat system is based on the grafting of *Manihot glaziovii* on a stock of *M. esculenta*. With this system, higher yields are obtained, and, especially in East Java, the practice is steadily expanding, mostly for homeyard production. Research is necessary to get more information about the possibilities of improving the Mukibat system, which has already been adopted by so many farmers. Some preliminary results from the first and the second year's experiments at Brawijaya University are presented here.

### Experiments

#### Preparation of Planting Material

Mukibat grafts were prepared by the splice grafting system. A 15-cm piece of stem of *M. glaziovii*, serving as a scion, was grafted on to a 25-cm stock of *M. esculenta*. The diameters of both scion and stock were between 20 and 30 mm. A thin piece of bamboo was put in the pith of both scion and stock to strengthen the union of the graft. Raffia fibres were used as binding material, but later it was found that a more elastic binding material or natural fibres such as banana leaf stalk fibres were better. The grafts were placed upside down for 5 days, and then put in a nursery under shade. The grafts that sprouted well were used in the experiments. For the normal system of planting, 30-cm cuttings (20–30 mm diameter) were used.

<sup>1</sup>Department of Soil Science, Faculty of Agriculture, Brawijaya University, Malang, Indonesia, and Department of Tropical Crop Science, Agricultural University, Wageningen, The Netherlands, respectively.

#### Planting

For the Mukibat system in the first year's experiments (1973/1974) planting holes (1 × 1 × 0.3 m) were made in most cases. In each hole, 20 kg of partly decomposed organic matter from market waste was mixed with soil. In the second year's experiments (1974/1976) planting holes and organic matter were not used.

The stakes were planted in a vertical position. For the Mukibat system, except in the plant density experiment, the spacing was 2 × 2 m in the first year's experiments, 1.5 × 1.5 m in the second year's experiments. For the normal system the spacing was 1 × 1 m. Planting was at the beginning of the rainy seasons.

#### Growth Period

For the Mukibat system in 1973/1974, except for the growth period experiment, harvesting occurred after 12 months; in 1974/1976 the growth period was 15 months. For the normal system, a 10 month growth period was used.

#### Effect of the Mukibat System on Yield

Experiments were carried out to compare the yield of local and improved varieties with the normal and the Mukibat system. Three locations were chosen for the 1973/1974 variety experiments and four locations for the 1974/1976 experiments. For 1974/1976 variety experiments data are available from only three locations. Mukibat and normal cassava experiments were carried out separately. In 1974/1976, an additional experiment was carried out at Muneng to compare yields obtained after different growth periods, both for the Mukibat and the normal system. Yields after

Table 1. Root yield (dry matter, t/ha, total and per month) of different varieties of the normal cassava (growth period 10 months) and of the Mukibat cassava (growth period 12 months) at three locations in the 1973/1974 experiments.

Location	Variety	Total yield		Yield per month	
		Normal	Mukibat	Normal	Mukibat
Pagak	Faroka	11.1	10.5	1.11	0.88
	Muneng 257	10.0	8.0	1.00	0.67
	Ketan	9.9	9.0	9.99	0.75
	Somo	9.0	9.5	0.90	0.79
	Ngganing	8.5	9.4	0.85	0.78
	Mentega	8.2	8.6	0.82	0.72
	Ambon	7.9	7.5	0.79	0.63
	Ndoro	7.9	6.7	0.79	0.56
	<i>Average</i>	9.1	8.7	0.91	0.72
	<i>C.V. (%)</i>	38	38		
	Muneng	Muara	6.2	5.4	0.62
259-D-Gm-42		5.4	5.4	0.54	0.45
Pandesi		5.2	7.0	0.52	0.58
Faroka		5.0	7.0	0.50	0.58
Gading		4.9	5.9	0.49	0.49
Ambon		4.4	6.4	0.44	0.53
Ngganing		4.2	6.9	0.42	0.58
260-E-Am-7		3.9	4.3	0.39	0.36
<i>Average</i>		4.9	6.0	0.49	0.50
<i>C.V. (%)</i>		38	37		
Lumajang	Faroka	12.3	13.6	1.23	1.13
	Muara	9.9	7.9	0.99	0.66
	257/B/Va	9.1	11.8	0.91	0.98
	Valenca	8.7	10.6	0.87	0.88
	Ndoro	8.6	13.2	0.86	1.10
	Ngganing	8.5	11.5	0.85	0.96
	Mentega	7.6	9.4	0.76	0.78
	Genjah Putih	6.6	9.4	0.66	0.78
	<i>Average</i>	8.9	10.9	0.89	0.91
	<i>C.V. (%)</i>	36	36		

growth periods of 10 and 12 months are available. The 1973/1974 data are shown in Table 1; the 1974/1976 data in Table 2.

The Mukibat system did not reduce the overall yield variation among the tested varieties. The coefficients of variation for both Mukibat and normal cassava at all locations were similar. However, the effect of the Mukibat system on the yield of individual varieties was not the same. High yielding varieties may not necessarily be high yielding when planted as Mukibat. The reverse is also true. Some varieties, like Ndoro and Mentega, responded better to the Mukibat system than other varieties. These are low yielding varieties that are preferred because of their good eating quality.

Yield per month was calculated for both

normal and Mukibat cassava to provide an indirect comparison of the productivity of both systems. There is an indication that in the 1974/1976 season the yield per month of the Mukibat cassava is much higher than that of the normal cassava. In the 1973/1974 season the Mukibat system did not produce more, and at Pagak even less, than the normal system. This unexpected result may be due to two reasons. First, the spacing,  $2 \times 2$  m, in the Mukibat system was too wide to allow optimal production. Second, preparation of planting material and planting of grafts was delayed by almost 2 months, which, according to farmers' experience, can reduce the yield of Mukibat plants considerably.

The results of the 1974/1976 variety experiments thus provide an indication that the

Table 2. Root yield (dry matter, t/ha, total and per month) of different varieties of the normal cassava (growth period 10 months) and of the Mukibat cassava (growth period 15 months) at three locations in the 1974/1976 experiments.

Location	Variety	Total yield		Yield per month	
		Normal	Mukibat	Normal	Mukibat
Tulungagung	Faroka 2	4.3	9.2	0.43	0.61
	Mentega	4.1	6.0	0.41	0.40
	Manggler	3.3	7.8	0.33	0.52
	Pandesi	3.3	8.3	0.33	0.55
	Caparoka	3.2	3.9	0.32	0.26
	Ndoro	1.7	7.6	0.17	0.51
	<i>Average</i>	3.32	7.13	0.33	0.48
	<i>C.V. (%)</i>	28	27		
Pagak	Pandesi	6.3	13.6	0.63	0.91
	Faroka 2	5.8	13.7	0.58	0.91
	Ndoro	5.4	12.6	0.54	0.84
	Faroka 1	5.1	11.1	0.51	0.74
	Raung	4.6	9.1	0.46	0.61
	Markati	3.4	10.8	0.34	0.72
	<i>Average</i>	5.1	11.82	0.51	0.79
	<i>C.V. (%)</i>	20	15		
Lumajang	Faroka 2	6.1	15.0	0.61	1.00
	Muara	5.8	15.8	0.58	1.05
	Valenca	5.1	12.7	0.51	0.85
	Ndoro	4.7	17.6	0.47	1.17
	Mentega	4.6	16.6	0.46	1.11
	257/B/Va	4.4	18.2	0.44	1.21
	<i>Average</i>	5.12	15.98	0.51	1.06
	<i>C.V. (%)</i>	14	12		

Mukibat system gives a higher root yield than the normal system, and these results correspond to farmers' experience of many years. The results of the experiments in which yields are compared after different growth periods support the indication that the yield potential of the Mukibat system is better than that of the normal cassava. The yields of three varieties (Faroka, Pandesi, and Ndoro) grown at Muneng, at two growth periods (10 and 12 months), were consistently higher with the Mukibat system. Experimentation is continuing.

#### Influence of the Planting Holes on Yield

Two experiments were carried out at two locations in 1973/1974 to evaluate the effect of planting holes for the Mukibat system. Under the Mukibat system, farmers often dig planting holes into which they put organic matter from the garden or kitchen. After filling the holes with soil mixed with the organic matter, the grafted cuttings are planted on top.

The treatments in the experiments were: (1) hoeing instead of hole; (2) hole  $1 \times 1 \times 0.3$  m; and (3) hole  $1 \times 1 \times 0.5$  m. They were arranged in subplots in a split-plot experiment, the main treatments being the varieties. Compost (50 t/ha) was mixed with the soil in the holes or while hoeing.

There was no beneficial effect of the holes on the yield, and the holes even significantly decreased the yield at Pagak. This suggests that making holes as one of the land preparations as done by some farmers may not be necessary. The practice of digging holes has been abandoned by farmers in regions where drainage of the land is poor. They usually plant on hills or ridges.

#### Relation Between Length of Growth Period and Yield

The relationship between the length of the growth period and the yield of the Mukibat cassava is one of the important factors deter-

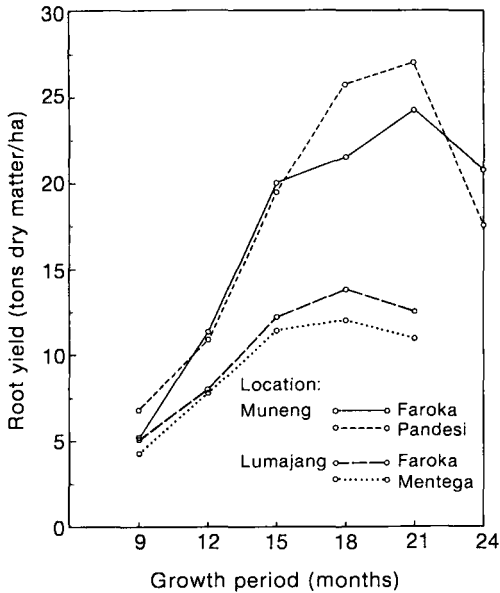

Fig. 1. Relationship between the length of growth period and yield of Mukibat cassava for three varieties at Muneng and Lumajang.

mining the optimum time for harvest. One experiment was carried out at each of two locations, Muneng and Lumajang, with two varieties per location. Planting was done at the beginning of the rainy season, December 1973, whereas at Lumajang replanting had to be done in February 1974 because of serious wind damage. Replanting reduced the number of replications. The material for replanting was obtained by cutting the stem above and below the union of the graft of the remaining plants. This replanting technique is common among the local farmers. Harvesting took place 9, 12, 15, 18, 21, and 24 months after planting or replanting. Results of dry matter root yield are presented in Fig. 1.

The highest accumulation of dry matter in the roots was obtained between 12 and 15 months with an average of 2.9 and 1.3 t/ha for the tested varieties at Muneng and Lumajang, respectively. A decrease in yield was obtained after 21 months (Muneng) and 18 months (Lumajang). This period coincided with the beginning of the rainy season, which started in early September in 1975. A lot of roots were rotten and consequently resulted in loss of yield. Harvest beyond 21 months at Lumajang was not possible because many trees

had fallen and were rotten. For both Muneng and Lumajang, the growth period could extend to 18 months. Harvesting after a shorter growth period would be necessary if root quality began to decrease earlier. Data on the development of root quality during the growth period are not yet available.

## Yield of Mukibat Cassava Using Different Kinds of Scion

### Original Versus Nonoriginal

#### *M. glaziovii* Material

Some farmers assume that the scion material should be taken from original *M. glaziovii* plants and not from the Mukibat plants (non-original). Experiments were carried out to compare the yield of Mukibat plants with scion derived from the original *M. glaziovii* tree with plants having scion derived from Mukibat plants at two locations in the 1973/1974 season.

At both locations there was no significant difference between the yield of Mukibat plants related to whether the scion derived from original or nonoriginal *M. glaziovii* material. This suggests that a scion taken from a Mukibat plant will be as good as that taken from the original *M. glaziovii* tree.

### "Black" Versus "White" Scion Material

Under the Mukibat system, farmers use more than one type of scion material. Most common is the so-called "black" type. Another type is called the "white" one. This one has a light coloured stem bark and the shape of the plant and its leaves is different from the "black" type, which has a dark green coloured stem bark.

At two locations, the yield of Mukibat plants derived from "black" scion material was compared to that of plants from "white" scions. The design was a split plot. Varieties were arranged in the main plots and the scion types were put in the subplots. At Pagak the root yield of the "black" type was superior to that of the "white" one, which corresponds to the experience of a majority of farmers. But at Lumajang no difference was found between the two types. Further research is still needed on this subject, and a botanical identification will be carried out to determine whether both types are *M. glaziovii*.

### Effects of N, P, and K on Yield

The use of fertilizers for cassava production in Indonesia is still very limited. Some farmers apply a small amount of urea, once or twice during the growth period (De Bruijn and Dharmaputra 1974).

To study the need of fertilizers for Mukibat cassava NPK experiments were carried out at two locations in East Java in 1974/1976. Only data from one of the locations, Tulungagung, are available. The chemical properties of the soil are as follows: pH = 6.1, organic-C = 0.55%, total-N = 0.04%, 0.03 N NH<sub>4</sub>F and 0.01 N HCl extractable P = 120 ppm, and N NH<sub>4</sub>-acetate extractable K = 66 ppm.

A split plot experiment was used. There were two varieties, Faroka and Ngoro, which constituted the main plots, while the combinations of N, P, and K fertilizers were arranged factorially in the subplots. P as TSP was applied 15 days after planting, N as urea and K as potassium sulfate were applied in equal split application 15 days and 4 months after planting, respectively.

The only significant effect was the N treatment. On average the application of urea equivalent to 100 kg N/ha resulted in twice the yield of the no N treatment. Further increase of the N rate did not significantly increase the yield.

### Discussion

The fact that an increasing number of farmers are adopting the Mukibat system is a strong indication that the system is superior to the normal cassava production system. The preliminary results of the experiments also indicate that the yield of the Mukibat cassava is

higher than that of the normal cassava if Mukibat cassava is planted at the right time with proper plant spacing.

Because the response of individual varieties to the Mukibat system varies considerably, the possibility exists of selecting for high yield within varieties that have good eating quality but only produce moderately under the normal system. This is very attractive in Indonesia where almost all cassava is used for human consumption.

The conclusion that making planting holes is not necessary has an important practical implication because labour input for the system can be reduced. This means that the system may be practical for larger fields. Another practical conclusion is that special *M. glaziovii* plantings for obtaining scion material may not be necessary, as the scions taken from the Mukibat plants proved to be as good as those taken from the original *M. glaziovii* tree. However, it is still not known whether scion material repeatedly taken from Mukibat plants without renewal from the original *M. glaziovii* trees will be effective. Further research is needed on this point.

The authors wish to thank the International Development Research Centre, which provided funds for the present research. We are indebted to staff members of the Cassava Research Project and students of the Faculty of Agriculture, Brawijaya University, for their active support and involvement in the cassava research, and to Dr. Graeme D. Swincer for correction of the English.

De Bruijn, G. H., and Dharmaputra, T. S. 1974. *The Mukibat system, a high yielding method of cassava production in Indonesia*. Neth. J. Agric. Sci. 22, 1974, 89-100.

## Undersowing Cassava with Stylo Grown Under Coconut

I. M. Nitis and M. Suarna<sup>1</sup>

Three field experiments on undersowing cassava with stylo were carried out in Bali. Stylo drilled under the cassava at diagonal crossing produced tuber dry matter (D.M.) similar to that of cassava sown without stylo. Other methods of sowing stylo (broadcast, windrow, crisscross, and drill midway between the 2 cassava) significantly ( $p = 0.05$ ) decreased the tuber D.M. yield by 32-51%. Windrow sowing the stylo under the cassava by replacing cassava with stylo so that the spacing increased from 40 × 40 cm

<sup>1</sup>Department of Nutrition and Pasture Agronomy, F.K.H.P., Udayana University, Denpasar, Bali, Indonesia.

### Effects of N, P, and K on Yield

The use of fertilizers for cassava production in Indonesia is still very limited. Some farmers apply a small amount of urea, once or twice during the growth period (De Bruijn and Dharmaputra 1974).

To study the need of fertilizers for Mukibat cassava NPK experiments were carried out at two locations in East Java in 1974/1976. Only data from one of the locations, Tulungagung, are available. The chemical properties of the soil are as follows: pH = 6.1, organic-C = 0.55%, total-N = 0.04%, 0.03 N NH<sub>4</sub>F and 0.01 N HCl extractable P = 120 ppm, and N NH<sub>4</sub>-acetate extractable K = 66 ppm.

A split plot experiment was used. There were two varieties, Faroka and Ngoro, which constituted the main plots, while the combinations of N, P, and K fertilizers were arranged factorially in the subplots. P as TSP was applied 15 days after planting, N as urea and K as potassium sulfate were applied in equal split application 15 days and 4 months after planting, respectively.

The only significant effect was the N treatment. On average the application of urea equivalent to 100 kg N/ha resulted in twice the yield of the no N treatment. Further increase of the N rate did not significantly increase the yield.

### Discussion

The fact that an increasing number of farmers are adopting the Mukibat system is a strong indication that the system is superior to the normal cassava production system. The preliminary results of the experiments also indicate that the yield of the Mukibat cassava is

higher than that of the normal cassava if Mukibat cassava is planted at the right time with proper plant spacing.

Because the response of individual varieties to the Mukibat system varies considerably, the possibility exists of selecting for high yield within varieties that have good eating quality but only produce moderately under the normal system. This is very attractive in Indonesia where almost all cassava is used for human consumption.

The conclusion that making planting holes is not necessary has an important practical implication because labour input for the system can be reduced. This means that the system may be practical for larger fields. Another practical conclusion is that special *M. glaziovii* plantings for obtaining scion material may not be necessary, as the scions taken from the Mukibat plants proved to be as good as those taken from the original *M. glaziovii* tree. However, it is still not known whether scion material repeatedly taken from Mukibat plants without renewal from the original *M. glaziovii* trees will be effective. Further research is needed on this point.

The authors wish to thank the International Development Research Centre, which provided funds for the present research. We are indebted to staff members of the Cassava Research Project and students of the Faculty of Agriculture, Brawijaya University, for their active support and involvement in the cassava research, and to Dr. Graeme D. Swincer for correction of the English.

De Bruijn, G. H., and Dharmaputra, T. S. 1974. *The Mukibat system, a high yielding method of cassava production in Indonesia*. Neth. J. Agric. Sci. 22, 1974, 89-100.

## Undersowing Cassava with Stylo Grown Under Coconut

I. M. Nitis and M. Suarna<sup>1</sup>

Three field experiments on undersowing cassava with stylo were carried out in Bali. Stylo drilled under the cassava at diagonal crossing produced tuber dry matter (D.M.) similar to that of cassava sown without stylo. Other methods of sowing stylo (broadcast, windrow, crisscross, and drill midway between the 2 cassava) significantly ( $p = 0.05$ ) decreased the tuber D.M. yield by 32-51%. Windrow sowing the stylo under the cassava by replacing cassava with stylo so that the spacing increased from 40 × 40 cm

<sup>1</sup>Department of Nutrition and Pasture Agronomy, F.K.H.P., Udayana University, Denpasar, Bali, Indonesia.

(without stylo) to 40 × 80 cm (with stylo) and from 60 × 60 cm (without stylo) to 60 × 120 cm (with stylo) increased tuber production by 20 and 22%, respectively. At the wider cassava spacing the replacement significantly decreased tuber D.M. yield by 28%. In the other experiment, windrow sowing stylo under the cassava decreased tuber D.M. yield by 14% ( $p = 0.05$ ). PK or PKT fertilizers could alleviate such yield depression. The cassava + stylo combination produced about 69% more shoot D.M. than that of the cassava sown without stylo. The importance of undersowing cassava with stylo in mixed farming systems is discussed.

In intensively farmed coconut-bearing dry areas in Bali, root crops (cassava, sweet potato), cereal (corn, sorghum), or beans (green bean, dolichos) are grown as cash crop while livestock is integrated into the farming system for draft animals, meat production, and export earnings. Cassava is the cash crop most commonly grown, and undersowing of cassava is rarely practiced. After the cassava crop, the land is either bare because it is too dry for new cultivation, or when enough moisture is available, it is invaded with annuals of low nutritive value. Shortage of livestock feed is not uncommon in this area (Nitis 1967). The tropical legume *Stylosanthes*, which is known for its drought resistance, and which can mix with other species (Humphreys 1969), is showing promise as a livestock feed in Bali (Nitis and Nurbudi 1975).

According to Nitis and Sumatra (1976), cassava undersown with *Stylosanthes* produces 14% more tubers than cassava grown alone. Furthermore, the companion crop *Stylosanthes* produces an additional 5 tons dry matter/ha/year.

This paper reports on a short term field study of the effect of method of sowing, spacing (density), and fertilizer on the yield of cassava and *Stylosanthes* sown under coconut.

## Materials and Methods

### Site and Land Preparation

The experiments were carried out in 1 ha coconut bearing land in Kuta, 2 km from the sea at 10 m elevation. The average annual rainfall is 1832 mm distributed mainly during the November to April rainy season (Steel and Humphreys 1974). The coconut trees are about 30 years old and are planted at approximately 10 × 10 m spacing. For many years the area has been cropped with cassava, green beans, peanuts, corn, and sweet potato. Recently, some parts have been used to evaluate various tropical legumes introduced to Bali.

The soil is a loamy fine sand (10 YR 3/2) overlaying loamy coarse carolline sand (7.5

YR 4/4) at 80–90 cm, with pH ranges from 6.5 to 8.5 at 0–80 cm depth (Steel and Humphreys 1974). The soil organic matter is 0.27% (Supardjata et al. 1974) and the water table is at 1.5–4.0 m.

The area was ploughed twice at 14 day intervals, hand weeded, and then hand ridged into raised beds (plots) 20 cm high. Spacing between plots was 1 m. Plot size in experiments 1 and 3 was 2 × 2 m, in experiment 2, 3 × 3 m.

### Cassava Stick and Stylo Seed

The sticks were cut from 10 month old cassava (*Manihot esculenta* var. *valenca*) obtained locally. Each 25 cm stick was planted perpendicular to the ground at 10 cm depth. Except in experiment 2, the sticks were planted at 80 × 80 cm spacing.

Stylo (*Stylosanthes guyanensis* cv. *schofield*) seeds obtained from Jember (East Java) were used. They were scarified mechanically and sown at the rate of 5 kg/ha. The seeds were not inoculated, and were sown 2 weeks after the cassava planting. Except in experiment 1, the seeds were sown midway between the cassava in a windrow direction at 1 cm depth.

### Experimental Design

Each experiment was carried out in a complete randomized design. Measurement of the height and number of leaves was carried out at 4-week intervals. At the same time, density of the stylo was measured in a 0.5 × 0.5 m quadrat. Stylo was harvested at 10 cm height. Plots with cassava without stylo were kept weed-free. The outermost plants were treated as a guard row and were not included in the measurements. After harvest, a proportional sample of leaf, stem, petiole, and tuber was dried at 70 °C to a constant weight for dry matter (D.M.) determination.

Experiment 1 was carried out to compare different methods of sowing stylo in relation to cassava. The treatments consisted of cassava alone and cassava + stylo using five methods of sowing stylo under cassava (broadcast, windrow, crisscross, drill midway between the

Table 1. Effect of method of sowing stylo under cassava on tuber yield and on cassava + stylo shoot.

Method of sowing stylo	D.M. yield of tuber (g/m <sup>2</sup> ) <sup>a</sup>	Number of tubers/m <sup>2</sup>	D.M. yield of cassava + stylo shoot <sup>b</sup> (g/m <sup>2</sup> )
No stylo (control)	41.57a	8.22a	224a
Broadcast	21.86b	3.75b	295b
Windrow	20.29b	3.64b	250a
Crisscross	28.14b	5.14f	297b
Drill midway	22.71b	7.14c	243a
Drill at diagonal crossing	45.29a	7.99c	307b
S.E.M.	3.26	0.34	3.19

<sup>a</sup>Values in the same column followed by different letters are significantly different ( $p = 0.05$ ).

<sup>b</sup>Stem + petiole + leaf blade.

two cassava, and drill at diagonal crossing of the four cassava) with seven replications in each treatment. Except for the broadcast, depth of sowing was 1 cm. The cassava sticks were planted on 13 September 1974, the cassava and stylo were harvested when the cassava was 26 weeks old (1 March 1975). Stylo re-growth and volunteer species invading the plot without stylo were harvested 16 weeks later (2 July 1975).

Experiment 2 studied various planting densities of cassava and stylo. The factorial design consisted of three combinations (cassava, stylo, and cassava + stylo), three spacing (40 × 40, 60 × 60, and 80 × 80 cm), and 12 replications. The cassava and cassava + stylo combination resulted in a 40 × 40, 40 × 80, 60 × 60, 60 × 120, 80 × 80, and 80 × 160 spacing with a density of 5.44, 2.67, 2.78, 1.67, 1.78, and 0.89 plant/m<sup>2</sup>, respectively for the cassava. The cassava sticks were planted on 15 September 1974, the cassava and stylo were harvested when the cassava was 41 weeks old (27 June 1975). Light intensity under the cassava canopy was measured by photocell light metre and leaf areas of the cassava were measured by planimetre.

Experiment 3 compared the response to nitrogen (N), phosphorus (P), potassium (K), and trace elements (T). It consisted of volunteer species (no cassava and no stylo); cassava alone fertilized with nothing, N, NPK, and NPKT; cassava + stylo fertilized with nothing, PK, and PKT; and stylo alone (12 replications each treatment). The elements were applied (kg/ha) as follows: N as urea at 165, P as triple superphosphate at 150, K as KCl at 85, and

T as CuSO<sub>4</sub>·5H<sub>2</sub>O at 8, ZnSO<sub>4</sub>·5H<sub>2</sub>O at 8, MnSO<sub>4</sub>·7H<sub>2</sub>O at 21.8, Na<sub>2</sub>MoO<sub>4</sub>·2H<sub>2</sub>O at 0.24, and Na<sub>2</sub>B<sub>4</sub>O<sub>7</sub>·10H<sub>2</sub>O at 4.5. Major elements were mixed thoroughly with soil and then broadcast on the plots. Trace elements Cu, Zn, Mn, Mo, and B were dissolved in water and then applied evenly on the plots. The cassava sticks were planted on 15 September 1974; the cassava and stylo were harvested when the cassava was 41 weeks old (29 June 1975).

### Statistical Analysis

Data were subjected to analysis of variance (Snedecor and Cochran 1967). When a significant difference was detected ( $p < 0.05$ ) it was evaluated by the new Duncan multiple range test (Steel and Torrie 1960).

## Results

### Methods of Sowing Stylo (Experiment 1)

Undersowing cassava with stylo at diagonal crossing did not significantly affect tuber D.M. yield (Table 1). On the other hand, sowing stylo by the other methods reduced tuber D.M. yield by 32.3–51.2% compared with that of the cassava sown without stylo. The crisscross method of sowing exerted the least effect and the windrow method the most.

In terms of cassava shoot growth, cassava undersown with stylo at diagonal crossing yielded 7.9% more shoot D.M. than that of cassava sown without stylo. This was due mainly to the increase in D.M. of the leaf and petiole, whereas the stem D.M. did not significantly vary. The other methods of sowing stylo decreased the shoot D.M. yield of the cassava

Table 2. Effect of plant density and stylo on tuber yield and on cassava + stylo shoot.

Spacing	Cassava density (plants/m <sup>2</sup> )	Combination	D.M. yield of tuber (g/m <sup>2</sup> ) <sup>a</sup>	Number of tubers/m <sup>2</sup>	D.M. yield of cassava + stylo shoot <sup>b</sup> (g/m <sup>2</sup> )
40 × 40	5.44	cassava	614a	8.01a	543a
40	—	stylo	—	—	656bg
40 × 80	2.67	cassava + stylo	737b	9.27b	1006c
60 × 60	2.78	cassava	566a	6.87c	464f
60	—	stylo	—	—	633b
60 × 120	1.67	cassava + stylo	689b	7.96a	904c
80 × 80	1.78	cassava	583a	5.64f	395n
80	—	stylo	—	—	626b
80 × 160	0.89	cassava + stylo	420c	3.91g	705g
S.E.M.			6.74	0.16	18.16

<sup>a</sup>Values in the same column followed by different letters are significantly different ( $p = 0.05$ ).

<sup>b</sup>Stem + petiole + leaf blade.

by 17.4 to 31.3% compared with that of cassava sown without stylo. Of the cassava plant parts, the leaf was affected the most, whereas the stem and petiole varied according to the treatments. Method of sowing has no significant effect on the number of leaves and height of the cassava.

Stylo sown in broadcast produced similar shoot D.M. to stylo sown crisscross, but 86.5, 85.6, and 35.6% more than stylo sown windrow, drill at diagonal crossing, and drill mid-way, respectively.

Although in most cases, the cassava + stylo combination decreased the shoot D.M. yield of individual species, the combined cassava + stylo shoot D.M. yields were 8.6–37.0% greater than that of cassava sown without stylo. This increase was mainly due to the change in the D.M. of the stem.

Four months after termination of the experiment, the volunteer species invading the plots formerly cultivated with cassava sown without stylo produced 30.7 g D.M./m<sup>2</sup> and the stylo regrowth produced 7.8–12.7 times this amount.

### Plant Density (Experiment 2)

Reducing the cassava density from 5.44 to 2.67 plants/m<sup>2</sup> by sowing stylo in the location of the cassava row significantly increased the tuber D.M. yield by 20.1% (Table 2). Reducing the density from 2.78 to 1.67 plants/m<sup>2</sup> resulted in a similar trend, but a further reduction from 1.78 to 0.89 resulted in a 28.0% reduction in tuber D.M. yield. In the absence of stylo, reducing the cassava density

from 5.44 to 2.78 and to 1.78 plants/m<sup>2</sup> did not significantly affect the tuber yield. In the case of the cassava + stylo combination, reducing the cassava density from 2.67 to 1.67 plants/m<sup>2</sup> had no significant effect, but a further reduction from 1.67 to 0.89 decreased shoot D.M. yield by 39.1%. The change in the tuber D.M. yield was mainly due to the tuber number, whereas the tuber size (length and diameter) did not consistently vary.

Reducing the cassava density from 5.44 to 2.67, 2.78 to 1.67, and 1.78 to 0.89 plants/m<sup>2</sup> by replacing the cassava with stylo decreased the shoot D.M. yield by 12.2, 7.3, and 30.3%, respectively. The effect of varying density on the D.M. yield of the cassava plant parts (stem, petiole, and leaf) followed the shoot D.M. pattern. The reduction in the leaf D.M. yield was partly due to the reduction in the size and number of leaves.

Increasing the stylo spacing from 40 to 60 and 80 cm did not significantly affect the shoot D.M. yield of the stylo. However, increasing the stylo spacing from 40 to 80, 60 to 120, and 80 to 160 cm by sowing cassava in the row space of the stylo significantly decreased the shoot D.M. yield of the stylo by 19.4, 24.0, and 31.7%, respectively. In the case of the cassava + stylo combination, increasing the spacing from 40 × 80 to 60 × 120 cm decreased the D.M. yield of the stylo shoot by 10.2%, whereas increasing from 60 × 120 to 80 × 160 cm had no significant effect. Number of tillers was not consistently affected by the spacing.

Although the cassava + stylo combination

Table 3. Effect of fertilizer and stylo on tuber yield and on cassava + stylo shoot.

Combination	Fertilizer	D.M. yield of tuber (g/m <sup>2</sup> ) <sup>a</sup>	Number of tubers/m <sup>2</sup>	D.M. yield of cassava + stylo shoot <sup>b</sup> (g/m <sup>2</sup> )
volunteer species		—	—	90a
cassava	none	729ab	7.37ac	408b
stylo		—	—	675g
cassava + stylo		628b	6.57b	876c
cassava	N	821ac	8.00a	452b
cassava	NPK	1014c	9.06a	459b
cassava	NPKT	714ab	6.99bc	401b
cassava + stylo	PK	674b	6.92b	989cf
cassava + stylo	PKT	713ab	7.00b	1002f
S.E.M.		2.74	0.72	1.26

<sup>a</sup>Values in the same column followed by different letters are significantly different ( $p = 0.05$ ).

<sup>b</sup>Stem + petiole + leaf blade.

decreased the shoot D.M. yield of the individual species, the combined cassava + stylo D.M. yields were 29.7 to 85.1% greater than that of cassava sown without stylo. The wider the spacing the smaller the D.M. discrepancies.

### Fertilizer Response (Experiment 3)

The addition of N and NPK to the cassava plot (without stylo) increased the tuber D.M. yield by 12.6 and 39.1%, respectively, more than that of cassava without fertilizer application (Table 3). The addition of NPKT had no significant effect. Undersowing cassava with stylo reduced the tuber D.M. yield by 13.9% compared with the cassava sown without stylo. Application of fertilizer PK or PKT to the cassava + stylo plots alleviated this yield reduction. The change in tuber D.M. yield was due mainly to the tuber number, to a lesser extent to tuber diameter, whereas tuber length had no significant effect.

Undersowing cassava with stylo resulted in a 12.5% reduction in shoot D.M. yield compared with that of cassava sown without stylo. The addition of either PK or PKT alleviated this yield depression. The height of the cassava and its plant parts (stem, petiole, and leaf) were not consistently affected by these treatments.

The cassava + stylo combination reduced shoot D.M. yield of the stylo by 23.1% compared with that of stylo sown without cassava. The addition of PK or PKT to the cassava + stylo plots did not alleviate this growth de-

pression. Tiller number, but not tiller height, of the stylo was significantly increased by the fertilizer treatments.

The cassava + stylo combination produced shoot D.M. twice that of the cassava sown without stylo, and 9.7 times that of the annual species that grew in the plots without cassava and/or stylo.

### Discussion

According to Nitis and Sumatra (1976), sowing stylo under cassava at diagonal crossing produced 14% more tuber D.M. than cassava sown without stylo. The smaller response (9%) in this study is presumably due to the poorer soil in which nutrient competition started to become important. Method of sowing stylo, plant density, and fertilizer response trials support this suggestion. The coconut trees might not exert any significant effect, because Steel and Humphreys (1974) have shown that pasture growth contiguous to coconut trees is similar to that farther from these trees. Furthermore, Nitis et al. (1975) have shown that coconut trees undersown with improved pasture and grazed by cattle produce 18% more nuts than the coconut trees without pasture and cattle.

Enyi (1973) reported that increasing the cassava density increased the tuber yield and that the calculated optimal density for maximum yield was 1.60 plants/m<sup>2</sup>. The present study confirmed this finding, and showed that tuber D.M. yield can be increased by 26% by

increasing the cassava density from 1.78 to 2.67 plants/m<sup>2</sup>, provided the latter is undersown with stylo. The stylo might contribute some nitrogen (Anonymous 1967), but not enough to maximize yield. The greater tuber D.M. yield of cassava fertilized with nitrogen than cassava undersown with stylo supports this suggestion.

Cassava undersown with stylo and harvested at 10 months produced 0.17 ton less tuber D.M. than cassava sown without stylo. On the other hand, the cassava + stylo combination produced about 10 tons/ha/year more shoot D.M. than cassava sown without stylo. This roughage would feed 2 or 3 head of Bali cattle. The loss in cassava yield would therefore be compensated for by the additional supply of livestock feed. Farmers, who otherwise cannot afford to keep cattle because of a shortage of livestock feed, would be able to keep one pair of cattle for their mixed farming practices.

Experiments are now underway in Bali to study the effect of livestock manures, different species of tropical legumes, graded levels of potassium and sulfur, and density-fertilizer combinations on the yield of cassava undersown with stylo. Factors such as frequency and height of cutting the stylo merit further study. It is anticipated that knowledge from the cassava-stylo work will contribute to the current research input, which according to Nestel (1974), is still too low in terms of the value of cassava and its growth potential.

The authors wish to express their appreciation to the Governor of Bali province for the CESS Grant for financial support, and the Dean of Faculty of Veterinary Science and Animal Husbandry, Udayana University for facilities. The assistance of Mr Kusumah, Mr Kreped, Mr Wiradnya, Miss Indrawati, and Mr Ngenteg for technical work and Miss Astri for typing are acknowledged with pleasure.

- Anonymous. *Nitrogen from tropical legumes*. Rural Res., Commonwealth Scientific and Industrial Research Organization, No. 59, 1967, p. 29.
- Enyi, B. A. *Growth rates of three cassava varieties (Manihot esculenta Crantz) under varying population densities*. J. Agric. Sci. Camb. 81, 1973, 15.
- Humphreys, L. R. *A guide to better pastures for the tropics and sub-tropics*. Second edition. Wright, Stephenson & Co. Ltd., Melbourne, 1969.
- Nestel, B. *Current trends in cassava research*. International Development Research Centre, Ottawa, IDRC-036e, 1974.
- Nitis, I. M. *Livestock feed supply and livestock feed requirement in Bali* (English summary). Udayana Univ., Denpasar, Bali, F.K.H.P. Bull. 012, 1967.
- Nitis, I. M., and Sumatra, I. G. *The effect of fertilizer on the growth and yield of cassava undersown with Stylosanthes at Penebel, Bali*. Udayana Univ., Denpasar, Bali, F.K.H.P. Bull. 048, 1976.
- Nitis, I. M., and Nurbudi, K. D. *The growth of Stylosanthes in the Island of Bali*. Dinas Pertenakan Prop. Bali, Report Series, 1975.
- Nitis, I. M., Rika, K., Supardjata, M., Nurbudi, K. D., and Humphreys, L. R. *Productivity of improved pastures grazed by Bali cattle under coconuts: a preliminary report*. Dinas Pertenakan Prop. Bali, Report Series, 1975.
- Snedecor, G. W., and Cochran, W. G. *Statistical methods*. Sixth edition, Iowa State Univ. Press, Ames, Iowa, 1967.
- Steel, R. J. H., and Humphreys, L. R. *Growth and phosphorus response of some pasture legumes sown under coconuts in Bali*. Trop. Grassland, 8(3), 1974, 171.
- Steel, R. G. D., and Torrie, J. H. *Principles and procedures of statistics*. McGraw-Hill Book Co., New York, 1960.
- Supardjata, M., Winaya, D. P., and Nitis, I. M. *Laporan short course on tropical pasture*. Udayana University, Denpasar, Bali, Report Series, 1974.

## Effect of Potassium on Tuber Yield and Nutrient Uptake of Yams

G. O. Obigbesan, A. A. Agboola, and A. A. A. Fayemi<sup>1</sup>

The highest tuber yields of *D. cayenensis* and *D. rotundata* (var. aro) were produced using 30 kg K<sub>2</sub>O/ha, whereas *D. alata* and *D. rotundata* (var. efuru) gave optimum performance with 60 kg K<sub>2</sub>O/ha. Yield differences due to varieties were significant in both years of the experiment, but significant responses to K application were obtained only in the 1975 experiment at the farm site where the exchangeable soil K was 0.151 meq/100 g.

K fertilizations raised the percentage of marketable (ware) tubers of all species except *D. rotundata* (var. aro). There were also varietal differences in the crude protein (5.2–8.3%) and mineral nutrient content. Nitrogen and potassium constituted the major nutrients removed in large amounts. The average nutrient removal via the tuber ranged between 128 and 155 kg N, 16.9 and 19.4 kg P, and 155 and 184 kg P per hectare.

Yams, *Dioscorea* spp., constitute a major staple food in the African diet, and are of socio-economic importance in the life of the growers. Despite the enormous labour requirements in land preparation, staking, and harvesting and the large quantity of planting material required for yam production (at least 2.5 t/ha) yams continue to be extensively grown in the tropics. Their popularity over other root crops like cassava, for example, may be ascribed to their high market value and the ease of their preparation.

Yam production is a multi-million Naira industry in Nigeria, which produces about half of the world's total supply on approximately 1.7 million ha (FAO 1974). Yam cultivation is done mainly by peasant farmers who have been advised by the Ministries of Agriculture to apply a complete fertilizer at the rate of 376 kg/ha for yam and all other crops (Anonymous 1962, 1963). However, it is essential to establish the response of yam varieties to fertilizers under different soil fertility levels, because earlier works (Obi 1959, Baker 1962, Sobulo 1972) did not give this sufficient attention. Our work investigated the performance of different yam varieties under different soil fertility levels.

### Materials and Methods

Four commonly grown yams: *D. rotundata* (var. efuru); *D. rotundata* (var. aro); *D. alata* (water yam); and *D. cayenensis* (yellow yam) were obtained from the local market and planted as early yams on 19 December 1973 and 12 January 1975. The first experiment

(1974) was conducted at the University of Ibadan farm on land that had not been continuously cropped for several years. Before ploughing and ridging, random soil samples were taken (0–15 cm) to establish the level of soil fertility. Planting was done on ridges 90 cm apart and at a spacing of 90 cm. A plot size of 3.6 × 6.4 m gave 40 plants/plot or about 17 285 setts/ha.

Potassium fertilizer was applied by band placement in trenches along the ridges and a few centimetres away from the yam setts at the rate of 0, 30, 60, 90, and 120 kg K<sub>2</sub>O/ha as muriate of potash with basal dressing of 90 kg N and 60 kg P<sub>2</sub>O<sub>5</sub>/ha in the form of ammonium sulfate and superphosphate, respectively. The yam vines were staked, and weeded as required. The crops were harvested when most of the leaves had dried up.

### Results

*D. alata* usually shed its leaves and dried up earliest, whereas *D. cayenensis* retained its leaves longest and matured last. In the 1975 experiment, there was a premature shedding of leaves, and all the *D. alata* plants dried out as early as July. The leaves showed characteristic insect damage symptoms, but leaf samples taken for microbiological examination revealed the causative agent to be *Cercospora*. The leaves of *D. rotundata* and *D. cayenensis* were resistant to this fungus. At harvest in 1975, some of the tubers of *D. rotundata* (var. efuru) were rotten, whereas tubers of *D. cayenensis* and *D. alata* were not affected.

### Tuber Yields

At harvest, the tubers from each plot were weighed and separated into marketable (ware)

<sup>1</sup>Department of Agronomy, University of Ibadan, Ibadan, Nigeria.

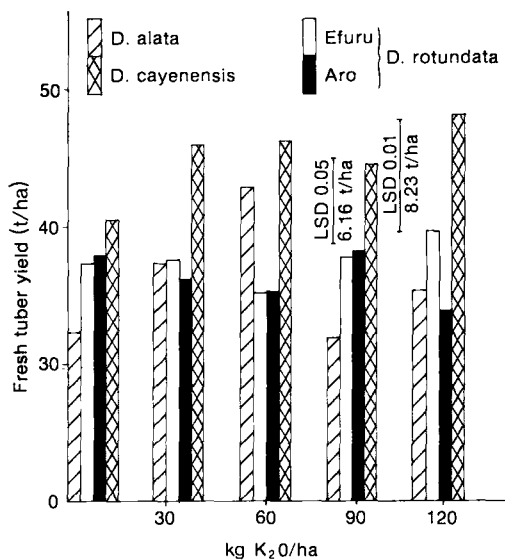

Fig. 1. Effect of K fertilization on tuber yields of yams (1974).

and nonmarketable yams. Figures 1 and 2 show the influence of K fertilization on tuber yields in 1974 and 1975, respectively. The 1974 crop gave a yield range of between 32.5 t/ha (*D. alata*) and 40.5 t/ha (*D. cayenensis*) without fertilizer, and between 43.0 t/ha (*D. alata*) and 46.5 t/ha (*D. cayenensis*) at the optimum fertilizer levels. *D. cayenensis* significantly outyielded the other species. Generally, response to K was rather low, with the best yield levels being obtained at rates of 30–60 kg K<sub>2</sub>O/ha (Fig. 1).

Considerably lower tuber yields were obtained in the 1975 experiment. These low yields were probably due to the poorer nutrient status of the experimental site and *Cercospora* attack on *D. alata*. However, there was a generally significant response to K fertilizer with significant interactions among the varieties. As in the previous year's result (Fig. 1), *D. cayenensis* significantly outyielded the other species (Fig. 2).

Response to K in 1975 was rather inconsistent (except for *D. alata*) although there was a definite trend of yield increases due to K application. *D. rotundata* (var. aro) and *D. cayenensis* gave highest yields when fertilized at 30 kg K<sub>2</sub>O/ha, *D. alata* at 60 kg K<sub>2</sub>O/ha, and *D. rotundata* (var. efuru) at 90 kg K<sub>2</sub>O/ha (Fig. 2). The differences between the mean

yields from fertilizer treatments were significant.

An assessment of the percentage of ware-tubers from the 1975 harvest showed that increased K application appreciably improved the amount of marketable tubers. This indicates that K fertilization not only increases tuber yield but also the quantity of marketable produce.

### Nutrient Removal

The average nutrient contents for the yam species are shown in Table 1. The data reveal that among the yam species, *D. alata* tubers without the peel had the highest crude protein (8.26%, on dry weight basis) and mineral content, whereas *D. cayenensis* had the lowest protein (5.19%) and lowest mineral content. The two varieties of *D. rotundata* (aro and efuru) also showed distinct differences in nutrient composition. The highest values were recorded for *D. rotundata* (var. efuru).

The nutrient levels obtained in this work are comparable to those reported by Ferguson (1969) who found that tubers of *D. alata* contained about 1.3% N (dry weight basis) and produced the lowest amount of dry matter (24.9%). The dry matter production of *D. rotundata* (var. efuru), *D. rotundata* (var. aro), and *D. cayenensis* was 32.9, 34.4, and

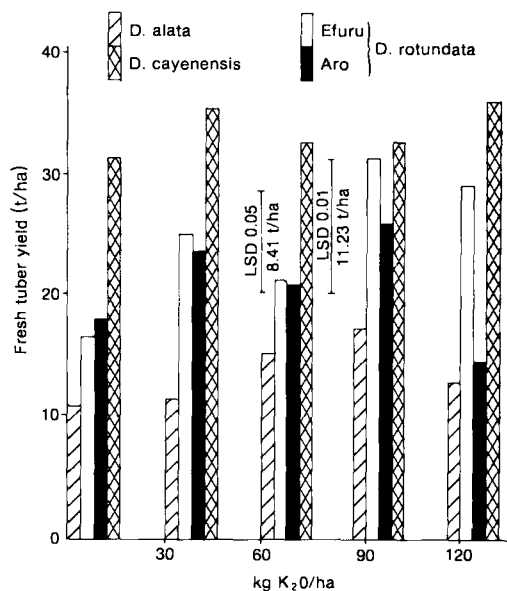

Fig. 2. Effect of K fertilization on tuber yields of yams (1975).

Table 1. Average nutrient content (mg/100 g tuber) of yams (dry weight basis).

Species	Portion analyzed	N	P	K	Ca	Mg
<i>D. alata</i>	unpeeled tuber	1.42	0.187	1.79	0.031	0.088
	peeled tuber	1.32	0.129	1.55	0.02	
<i>D. rotundata</i> (var. <i>efuru</i> )	unpeeled tuber	1.28	0.150	1.45	0.032	0.088
	peeled tuber	1.22	0.124	1.33	0.02	
<i>D. rotundata</i> (var. <i>aro</i> )	unpeeled tuber	1.15	0.148	1.27	0.028	0.092
	peeled tuber	1.12	0.130	1.17	0.015	
<i>D. cayenensis</i>	unpeeled tuber	0.91	0.127	1.19	0.025	0.086
	peeled tuber	0.83	0.098	0.93	0.015	

Table 2. Nutrient removal (kg/ha) through the tubers of the yam species.

Yam species	Average dry matter yield (kg/ha)	Average nutrient removal (kg/ha)				
		N	P	K	Ca	Mg
<i>D. alata</i>	9034	128.3	16.9	161.7	2.8	7.9
<i>D. rotundata</i> (var. <i>efuru</i> )	12133	155.3	18.2	175.9	3.9	10.7
<i>D. rotundata</i> (var. <i>aro</i> )	12197	140.3	18.1	154.9	3.4	11.2
<i>D. cayenensis</i>	15255	138.8	19.4	181.5	3.8	13.1

34.3%, respectively. The level of nutrient removal of the different species is presented in Table 2. Two major aspects are reflected in this table: (1) nitrogen and potassium are the most important nutrients removed from the soil and deposited in the tubers; and (2) yam species have different nutrient requirements. At the yield level of 13 716 kg tubers/ha (dry weight basis), *D. rotundata* (var. *efuru*) was estimated to remove as much as 175.6 kg N, 20.6 kg P, 198.0 kg K, 4.4 kg Ca, and 12.1 kg Mg per hectare — an equivalent of about 836 kg ammonium sulfate (21% N), 114 kg single superphosphate (18% P<sub>2</sub>O<sub>5</sub>), and 333 kg muriate of potash (60% K<sub>2</sub>O) per hectare.

## Discussion

Soil analysis showed that the K nutrient status of the 1974 experimental site was higher (exch. K = 0.218 meq/100 g) than that of 1975 (exch. K = 0.151 meq/100 g). This was probably the cause of the generally low and insignificant response to K fertilizer in 1974, whereas significant yield increases were obtained in 1975. Moreover, the 1974 experimental site was an area cleared from bush that had lain fallow (*Imperata* grass) for some years, while the farm site (1975 experiment) had been under continuous use for many years. It appears that yams will not respond to K

fertilizer when the level of exchangeable K is greater than 0.15 meq/100 g soil on newly cleared land.

Our work agrees with the observations made by Heathcote and Stockinger (1970), in savanna areas of northern Nigeria, that cereal crops responded to K fertilizer when the exchangeable K fell below 0.2 meq/100 g soil and of Forde et al. (1966), in southern Nigeria, that the minimum requirements of oil-palms for exchangeable K was 0.10 meq/100 g soil.

Premature death of *D. alata* plants in July owing to *Cercospora* fungus attack indicates the differential susceptibility and resistance of the yam species. *D. cayenensis* with thicker cutinous foliage was not affected by the disease. Many of the tubers of *D. rotundata* (var. *efuru*) were prone to decay as a result of the high water table during the late rains of August–September 1975, whereas none of the tubers of *D. alata* was adversely affected.

Yield reduction, based on the 1974 crop, was least marked in *D. cayenensis* (26%) followed by *D. rotundata* (var. *efuru*) (37.7%) and *D. rotundata* (var. *aro*) (44%). In general, the mean yields obtained in both years were higher than the average of 16 113 kg/ha reported for *D. rotundata* by Sobulo (1972) at a similar planting time (Nov/Dec) but were comparable to those reported by Ferguson and Haynes (1970).

Besides being an important source of carbohydrate and the chief source of saprogenic precursors of cortisone (Martin and Ortiz 1963), yams provide much needed minerals in the diet. Table 2 shows that the tubers of *D. alata* were much richer in protein and mineral nutrients than the other yam species; the protein content of its peeled tuber (8.76%) was about 60% more than that of *D. cayenensis*; 18% more than that of *D. rotundata* (var. aro), and 8% greater than that of *D. rotundata* (var. efuru). Busson (1965) reported that the protein in the tuber of *D. alata* contained even higher amounts of essential amino acids than that of *D. cayenensis*. This is of significant interest to Nigerians who have a preference for using *D. alata* for making a much relished porridge called "Ikokore."

It is to be expected that continuous cultivation of yams in the same soil would rapidly deplete the soil of its nitrogen and potash reserves (Table 2). The danger might not be as imminent in soils derived from metamorphic parent material rich in K reserve, e.g. in the savanna zone of western Nigeria, as in soils of sedimentary origin, e.g. rainforest zone of southern Nigeria, which are known to be very low in potash (Smyth and Montgomery 1962).

Therefore, yam production in the rainforest zone of southern Nigeria requires a judicious application of N and K for high yields.

The authors appreciate the skillful assistance of P. S. I. Makam in the field work and J. A. Williams in the laboratory analyses.

Anonymous. *Agriculture Division. Annual Report 1960-61*. Ministry of Agriculture, Eastern Nigeria, Official Document No. 21, 1962.

*Annual Report 1961-62. Research Division*. Ministry of Agriculture and Natural Resources, Western Nigeria, 1963.

Baker, E. F. I. *Agronomic studies with white yam 1954-61*. Ministry of Agriculture and Natural Resources, Western Nigeria, Report, 1962.

Busson, F. *Plantes alimentaires de l'Ouest africain*. Leconte, Marseille, 1965.

FAO. *FAO fertilizer programme. The first decade: A summary of results achieved between 1961 and 1971*. Centre d'Etude de l'Azote, Zurich, Nov, 1974.

Ferguson, T. U. *Mineral and calorie content of yam tubers*. Annual Report 1968-69. Faculty of Agriculture, University of West Indies, Trinidad, 1969.

Ferguson, T. U., and Haynes, P. H. *The response of yams (Dioscorea spp.) to nitrogen, phosphorus, potassium, and organic fertilizers*. Proc. 2nd Int. Symp. Trop. Root and Tuber Crops, 1, 1970, 93-96.

Forde, St. C. M., Leyritz, M. J. P., and Sly, J. M. A. *The importance of potassium in the nutrition of the oil palm in Nigeria*. Potash Review, 46, 1966, 1-11.

Heathcote, R. G., and Stockinger, K. R. *Soil fertility under continuous cultivation in Northern Nigeria. 2: Responses to fertilizers in the absence of organic manures*. Expl. Agric. 6, 1970, 345-350.

Martin, F. W., and Ortiz, S. *Origin and anatomy of tubers of Dioscorea floribunda and D. spiculiflora*. Botanical Gazette, 124, 1963, 416.

Obi, J. K. *The standard DNPk experiments*. Regional Research Station Samaru, Nigeria, Tech. Rep. No. 8, 1959.

Smyth, A. J., and Montgomery, R. R. *Soils and land use in central Western Nigeria*. The Government of Western Nigeria, Ibadan, 1962.

Sobulo, R. A. *Studies on white yam (Dioscorea rotundata) I. Growth analysis*. Experimental Agriculture, 8, 1972, 99-106.

## Effect of Potassium and Sulfur on Growth, Yield, and Composition of Cassava

A. G. N. Ngongi, R. Howeler, and H. A. MacDonald<sup>1</sup>

Three field experiments were conducted in Colombia to investigate the differential effects of KCl and K<sub>2</sub>SO<sub>4</sub> on cassava root yields. At Pance, where soil SO<sub>4</sub><sup>=</sup>-S content was 9.0 ppm, there were no differences in yields between KCl and K<sub>2</sub>SO<sub>4</sub> plots, but at Carimagua and Tranquero where soil SO<sub>4</sub><sup>=</sup>-S content was 4.0-4.5 ppm, K<sub>2</sub>SO<sub>4</sub> produced

<sup>1</sup>Cornell University, Ithaca, N.Y.; CIAT, Cali, Colombia; and Cornell University, respectively. Present address of the senior author is Soil Research Institute, Kwadaso, Kumasi, Ghana. This study was financed by Cornell University, the Ford Foundation, and Centro Internacional de Agricultura Tropical.

Besides being an important source of carbohydrate and the chief source of saprogenic precursors of cortisone (Martin and Ortiz 1963), yams provide much needed minerals in the diet. Table 2 shows that the tubers of *D. alata* were much richer in protein and mineral nutrients than the other yam species; the protein content of its peeled tuber (8.76%) was about 60% more than that of *D. cayenensis*; 18% more than that of *D. rotundata* (var. aro), and 8% greater than that of *D. rotundata* (var. efuru). Busson (1965) reported that the protein in the tuber of *D. alata* contained even higher amounts of essential amino acids than that of *D. cayenensis*. This is of significant interest to Nigerians who have a preference for using *D. alata* for making a much relished porridge called "Ikokore."

It is to be expected that continuous cultivation of yams in the same soil would rapidly deplete the soil of its nitrogen and potash reserves (Table 2). The danger might not be as imminent in soils derived from metamorphic parent material rich in K reserve, e.g. in the savanna zone of western Nigeria, as in soils of sedimentary origin, e.g. rainforest zone of southern Nigeria, which are known to be very low in potash (Smyth and Montgomery 1962).

Therefore, yam production in the rainforest zone of southern Nigeria requires a judicious application of N and K for high yields.

The authors appreciate the skillful assistance of P. S. I. Makam in the field work and J. A. Williams in the laboratory analyses.

Anonymous. *Agriculture Division. Annual Report 1960-61*. Ministry of Agriculture, Eastern Nigeria, Official Document No. 21, 1962.

*Annual Report 1961-62. Research Division*. Ministry of Agriculture and Natural Resources, Western Nigeria, 1963.

Baker, E. F. I. *Agronomic studies with white yam 1954-61*. Ministry of Agriculture and Natural Resources, Western Nigeria, Report, 1962.

Busson, F. *Plantes alimentaires de l'Ouest africain*. Leconte, Marseille, 1965.

FAO. *FAO fertilizer programme. The first decade: A summary of results achieved between 1961 and 1971*. Centre d'Etude de l'Azote, Zurich, Nov, 1974.

Ferguson, T. U. *Mineral and calorie content of yam tubers*. Annual Report 1968-69. Faculty of Agriculture, University of West Indies, Trinidad, 1969.

Ferguson, T. U., and Haynes, P. H. *The response of yams (Dioscorea spp.) to nitrogen, phosphorus, potassium, and organic fertilizers*. Proc. 2nd Int. Symp. Trop. Root and Tuber Crops, 1, 1970, 93-96.

Forde, St. C. M., Leyritz, M. J. P., and Sly, J. M. A. *The importance of potassium in the nutrition of the oil palm in Nigeria*. Potash Review, 46, 1966, 1-11.

Heathcote, R. G., and Stockinger, K. R. *Soil fertility under continuous cultivation in Northern Nigeria. 2: Responses to fertilizers in the absence of organic manures*. Expl. Agric. 6, 1970, 345-350.

Martin, F. W., and Ortiz, S. *Origin and anatomy of tubers of Dioscorea floribunda and D. spiculiflora*. Botanical Gazette, 124, 1963, 416.

Obi, J. K. *The standard DNPk experiments*. Regional Research Station Samaru, Nigeria, Tech. Rep. No. 8, 1959.

Smyth, A. J., and Montgomery, R. R. *Soils and land use in central Western Nigeria*. The Government of Western Nigeria, Ibadan, 1962.

Sobulo, R. A. *Studies on white yam (Dioscorea rotundata) I. Growth analysis*. Experimental Agriculture, 8, 1972, 99-106.

## Effect of Potassium and Sulfur on Growth, Yield, and Composition of Cassava

A. G. N. Ngongi, R. Howeler, and H. A. MacDonald<sup>1</sup>

Three field experiments were conducted in Colombia to investigate the differential effects of KCl and K<sub>2</sub>SO<sub>4</sub> on cassava root yields. At Pance, where soil SO<sub>4</sub><sup>=-S</sup> content was 9.0 ppm, there were no differences in yields between KCl and K<sub>2</sub>SO<sub>4</sub> plots, but at Carimagua and Tranquero where soil SO<sub>4</sub><sup>=-S</sup> content was 4.0-4.5 ppm, K<sub>2</sub>SO<sub>4</sub> produced

<sup>1</sup>Cornell University, Ithaca, N.Y.; CIAT, Cali, Colombia; and Cornell University, respectively. Present address of the senior author is Soil Research Institute, Kwadaso, Kumasi, Ghana. This study was financed by Cornell University, the Ford Foundation, and Centro Internacional de Agricultura Tropical.

significantly higher root yields than KCl. A KCl + S 'source' produced yields equal to those produced by  $K_2SO_4$  at equivalent rates of potassium.

Cassava root yields increased with potassium fertilization. Potassium applied at a rate of 120 kg  $K_2O$ /ha appeared to be adequate. Maximum root yields obtained were 40 and 20 t/ha at Pance and Tranquero, respectively. There was a high positive correlation between cassava root yields and total plant fresh weight produced per hectare.

Cassava has been reported to respond well to potassium fertilization by several investigators; however, yield depressions have also been reported at potassium rates higher than 200 kg  $K_2O$ /ha applied in the form of KCl (CIAT 1974, Kumar et al. 1971, Samuels 1970). Similar yield depressions at high potassium rates have been reported for yams (Ferguson and Haynes 1970) and for sweet potato (Duncan et al. 1958). The yield depressions have remained unexplained, but it has been suggested that the chloride ion has some deleterious effects on starch accumulation (Oke 1968).

The principal objectives of this study were: (1) to investigate the differential effects of two potassium sources, potassium chloride and potassium sulfate, on cassava root yields; and (2) to evaluate the main effects of sulfur on cassava root yields obtained from highly weathered soils.

## Materials and Methods

Three experiments were conducted in Colombia at Pance, Carimagua, and Tranquero. Pance is located 14 km south of Cali in the Cauca Valley of Colombia at an altitude of about 1000 m. The soil, which is derived from volcanic ash, is heavy and poorly drained. Carimagua is located in the Eastern Plains of Colombia, South of the Meta River. The area has a gently sloping topography with an average elevation of 150–200 m. The mean annual rainfall of the area is 1800 mm and the mean annual temperature is 26–27 °C. Tranquero is located 10 km North of Carimagua. The soil at Carimagua has been classified as a clayey,

kaolinitic isohyperthermic typic haplustox (Naderman 1973). The soil at Tranquero was very similar to that found at Carimagua. Chemical data on the soils at the three sites are presented in Table 1.

The treatments imposed on the three experiments were two sources and four rates of potassium fertilizer. Potassium chloride (KCl) and potassium sulfate ( $K_2SO_4$ ) were the potassium sources used and potassium was applied at rates of 0, 60, 120, and 240 kg  $K_2O$ /ha at Pance and Tranquero and 60, 90, 120, and 240 kg  $K_2O$ /ha at Carimagua. A KCl + S 'source' was included at Tranquero to investigate the effects of the sulfur contained in  $K_2SO_4$ . Elemental sulfur was applied in amounts equivalent to the sulfur content of each rate of potassium applied as  $K_2SO_4$ .

A basal application of 100 kg N (as urea) per hectare was made at all sites. Phosphorus was applied at a rate of 75 kg  $P_2O_5$  at Pance and 100 kg  $P_2O_5$ /ha at Carimagua and Tranquero. Lime, which had a Ca/Mg ratio of 10/1.0 was applied at a rate of 0.5 t/ha at Carimagua and Tranquero. Zinc was applied at a rate of 5.0 kg/ha as  $ZnSO_4$ . Potassium, nitrogen, and sulfur (at Tranquero) were split applied in double bands, half at planting and half 2 months later at Pance and Carimagua. The second application was made 1 month after planting at Tranquero to take advantage of the last rains. Half the phosphorus was applied during the liming operation and the rest was applied at planting. All the zinc was applied at planting.

A split-plot design with potassium sources as main plots and potassium rates as split plots was used at Pance and Carimagua. Potassium

Table 1. Characteristics of the soils at Pance, Carimagua, and Tranquero (0–15 cm).

	(1:1 $H_2O$ )	O.M. (%)	P (Bray II) (ppm)	$SO_4^{2-}$ -S (ppm)	Al <sup>+++</sup> (meq/ 100 g)	Ca (meq/ 100 g)	Mg (meq/ 100 g)	K (meq/ 100 g)
Pance	5.6	5.0	2.4	9.0	—	9.7	5.70	0.11
Carimagua	4.8	5.0	0.9	4.0	3.7	0.3	0.30	0.13
Tranquero	4.9	2.5	1.8	4.5	1.6	0.1	0.05	0.05

Table 2. Effect of potassium sources and rates of application on total plant fresh weight, root yield, and harvest index of cassava 40 weeks after planting at Pance, Carimagua, and Tranquero.

K source	K rate (K <sub>2</sub> O kg/ha)	Pance		Carimagua <sup>a</sup>		Tranquero	
		Total plant fresh wt (t/ha)	Root yield (t/ha)	Total plant fresh wt (t/ha)	Root yield (t/ha)	Total plant fresh wt (t/ha)	Root yield (t/ha)
KCl	0	42.0	29.0	—	—	17.2	9.5
	60	47.6	31.0	8.5	4.5	19.4	11.4
	90	—	—	9.0	5.0	—	—
	120	54.8	40.0	8.5	4.8	24.4	15.7
	240	65.8	44.3	8.5	4.5	23.7	13.9
K <sub>2</sub> SO <sub>4</sub>	0	46.6	31.3	—	—	—	—
	60	49.6	35.5	14.5	9.0	23.2	13.8
	90	—	—	15.0	9.0	—	—
	120	61.3	42.3	15.0	9.5	25.8	15.8
	240	62.5	43.4	18.0	11.5	30.3	19.0
KCl + S	60	—	—	—	—	24.8	16.1
	120	—	—	—	—	22.8	15.2
	240	—	—	—	—	29.3	18.4

<sup>a</sup>There was a serious outbreak of cassava bacterial blight 2 months after planting.

rates were main plots and potassium sources split plots at Tranquero. There were three replications at Pance and Tranquero and four replications at Carimagua.

Mature stems of the cultivar Llanera were obtained from the CIAT farm at Palmira. These were cut into 20–25 cm lengths and planted in a vertical position on ridges. Spacing was 1.0 × 1.0 m giving a density of 10 000 plants/ha. The experiments at Pance and Carimagua were planted on 3 April and 4 May 1974, respectively, at the beginning of the rainy season. The Tranquero experiment was planted on 1 October 1974, toward the end of the rains. Harvesting was carried out 40 weeks after planting at Pance and Carimagua and 38 weeks after planting at Tranquero. Ten central plants constituted the harvest sample at Pance and Carimagua. At Tranquero, 12 central plants were harvested.

Data collected included plant height, total plant fresh weight, root yield, and harvest index. At Tranquero, root number per plant, root size, and percentage marketable root yield were also determined. A marketable root weighed approximately 250 g. Leaf samples were taken for N and K analysis. Samples from Tranquero were also analyzed for sulfur. The fifth opened leaf from the top was the sample leaf. Root samples were taken at Tranquero, at harvest,

for N, K, S, and Cl analysis. The roots were washed, towel dried, and cut into small portions to facilitate drying. The leaf and root samples were dried in a forced air oven at 70 °C for 15 h and ground in a small Wiley mill to pass a 40 mesh screen. Prior to grinding, the leaves were separated into blades and petioles. Nitrogen was determined by micro-Kjeldahl, potassium by flame photometry, and leaf blade sulfur by the turbidimetric method of Tabatabai and Bremner (1970). Root sulfur and chloride contents were determined by the Analytical Service Laboratory, Department of Agronomy, Cornell University.

## Results

### Growth

Plant growth was vigorous at Pance and there were no significant differences in height between plants in plots receiving potassium as K<sub>2</sub>SO<sub>4</sub> and those receiving potassium as KCl. At both Carimagua and Tranquero, plants in plots fertilized with potassium as K<sub>2</sub>SO<sub>4</sub> were significantly taller than those receiving potassium from KCl. Plant height increased with potassium rates.

Total plant fresh weight produced per hectare was greatly increased by potassium fertilization (Table 2). At both Carimagua and

Table 3. Influence of potassium sources and rates of application on potassium and nitrogen contents of various plant parts and size of roots.

K source	K rate (K <sub>2</sub> O kg/ha)	K content (meq/100 g)				N content of roots (%) (Tranquero) <sup>c</sup>	Size of roots (g) (Tranquero) <sup>c</sup>
		Leaf blades		Petioles	Roots		
		Pance <sup>a</sup>	Tranquero <sup>b</sup>	(Tranquero) <sup>b</sup>	(Tranquero) <sup>c</sup>		
KCl	0	12.8	25.6	10.2	7.7	0.71	226
	60	18.7	37.0	41.0	12.8	0.62	317
	120	18.7	42.2	56.3	15.9	0.64	341
	240	20.5	42.2	66.6	18.0	0.54	290
K <sub>2</sub> SO <sub>4</sub>	0	14.0	—	—	—	—	—
	60	15.4	37.1	33.3	14.6	0.51	300
	120	17.4	41.0	55.0	18.4	0.43	310
	240	25.6	42.2	64.0	20.5	0.47	375
KCl + S	60	—	37.1	30.7	12.8	0.44	343
	120	—	41.0	56.3	17.0	0.54	300
	240	—	42.2	56.3	17.0	0.46	328

<sup>a</sup>Sampled 24 weeks after planting.<sup>b</sup>Sampled 32 weeks after planting.<sup>c</sup>Sampled 38 weeks after planting.

Tranquero, plant fresh weight was significantly higher in plots receiving potassium as potassium sulfate than that obtained in plots receiving potassium as potassium chloride. Plant fresh weight production increased with increasing rates of potassium when K<sub>2</sub>SO<sub>4</sub> was the potassium source but decreased at the highest rate of potassium when KCl was the potassium source at Carimagua and Tranquero but not at Pance. The KCl + S 'source' produced amounts of fresh plant material equal to those produced by the K<sub>2</sub>SO<sub>4</sub> source at equivalent potassium rates.

### Root Yield

Potassium fertilization increased cassava root yields significantly over those of control plots at both Pance and Tranquero (Table 2). At Carimagua there were no control plots and rates of potassium higher than 60 kg K<sub>2</sub>O/ha did not produce significantly higher root yields than the 60 kg/ha rate (Table 2). The K<sub>2</sub>SO<sub>4</sub> source produced significantly higher root yields than the KCl source at both Carimagua and Tranquero but not at Pance. The KCl + S 'source' produced yields that were equal to those obtained from plots receiving potassium as K<sub>2</sub>SO<sub>4</sub>. This indicated that the main reason for the superiority of K<sub>2</sub>SO<sub>4</sub> over KCl as a source of potassium for cassava at Carimagua and Tranquero was its sulfur content.

There was a depression in cassava root yields at the highest rate of potassium applied as KCl at Tranquero, but this did not occur when K<sub>2</sub>SO<sub>4</sub> or KCl + S were the sources of potassium. Cassava root yields at Pance and Tranquero were positively correlated with total plant fresh weight produced per hectare.

### Harvest Index

At Carimagua, plants receiving potassium as K<sub>2</sub>SO<sub>4</sub> had higher harvest indices than those receiving potassium as KCl. Harvest index remained relatively stable at all rates of potassium applied as K<sub>2</sub>SO<sub>4</sub> at Carimagua, but decreased at high rates of potassium when KCl was the potassium source. This difference could be attributed to the fact that CBB was initially more severe in KCl plots because of the less vigorous growth of the plants. Harvest index was not significantly affected by potassium sources or rates of application at Pance and Tranquero.

### Root Number

Potassium fertilization did not have a significant effect on the number of storage roots per plant and there were no differences among potassium sources on the number of storage roots produced per plant.

### Root Size

The size of cassava roots was increased by

Table 4. Influence of potassium sources and rates of application on sulfur and chloride contents and nitrogen/sulfur ratio of selected plant parts sampled at Tranquero.

K source	K rate (K <sub>2</sub> O kg/ha)	Sulfur content (%)			Chloride content of roots (%)	N/S ratio		
		Leaf blade		Roots		Leaf blade		Roots
		12 wks <sup>a</sup>	24 wks	(38 wks)	(38 wks)	12 wks	24 wks	(38 wks)
KCl	0	0.27	0.34	0.06	0.05	17.7	15.1	12.0
	60	0.30	0.54	0.06	0.07	15.9	15.2	10.0
	120	0.27	0.30	0.05	0.09	18.9	16.9	12.8
	240	0.29	0.29	0.06	0.11	16.7	17.2	9.0
K <sub>2</sub> SO <sub>4</sub>	60	0.37	0.37	0.06	0.05	12.8	13.7	8.5
	120	0.37	0.33	0.06	0.06	13.6	15.2	7.2
	240	0.37	0.33	0.06	0.06	13.6	14.8	7.8
KCl + S	60	0.31	0.38	0.05	0.06	16.1	13.3	8.8
	120	0.29	0.32	0.06	0.07	17.8	16.2	9.0
	240	0.30	0.35	0.05	0.09	17.0	15.1	9.2

<sup>a</sup>Number of weeks indicates time of sampling after planting.

potassium fertilization. Potassium rates higher than the 60 kg K<sub>2</sub>O/ha rate did not produce larger roots than those produced by plants receiving potassium at the rate of 60 kg K<sub>2</sub>O/ha. Only the K<sub>2</sub>SO<sub>4</sub> source produced consistent increases in root size with increasing rates of potassium fertilizer.

#### Percentage Marketable Root Yield

Potassium fertilization increased percentage marketable root yield from 70 to over 80%, but the difference was not significant. There was no significant difference among potassium sources in percentage marketable root yield although it was consistently higher in plots receiving potassium as K<sub>2</sub>SO<sub>4</sub> compared to KCl plots.

#### Potassium

Leaf blade and petiole potassium contents are presented in Table 3, along with potassium contents of cassava root samples from Tranquero. There was a generally good relationship between soil applied potassium and the potassium contents of the plant parts sampled. Petioles seemed to be more sensitive than either leaf blades or roots in detecting changes in the potassium status of cassava plants in relation to soil applied potassium fertilizer. The potassium contents of leaf blade samples from Pance were lower than those of leaf blades from Carimagua and Tranquero. This was partly a dilution effect owing to the greater amount

of plant material produced at Pance. The higher base status of the soil at Pance also probably resulted in a much greater uptake of calcium and magnesium by plants grown at Pance compared to those grown at Carimagua or Tranquero, thus reducing the concentration of potassium in plant cells (Itallie 1948).

#### Nitrogen

Potassium fertilization did not have a significant effect on the nitrogen content of the plant parts sampled (Table 3), except for root samples from Tranquero, which showed a marked reduction in nitrogen content as a result of potassium fertilization.

#### Sulfur

During the dry season, 8–20 weeks after planting at Tranquero, cassava plants in control plots and plots fertilized with potassium as KCl showed symptoms of sulfur deficiency. Leaves in these plots were small and had a yellowish-green coloration. Plants in plots fertilized with potassium as K<sub>2</sub>SO<sub>4</sub> and KCl + S produced large green leaves.

The sulfur content of leaf blade samples taken 12 weeks after planting increased when K<sub>2</sub>SO<sub>4</sub> and KCl + S were the sources of potassium, but changed little when KCl was the potassium source (Table 4). At 24 weeks, leaf blade samples from plots receiving potassium as KCl showed a slight decrease in sulfur content compared to samples from con-

trol plots. Samples from plots receiving potassium as  $K_2SO_4$  and  $KCl + S$  had sulfur contents that were higher than those of samples from  $KCl$  plots. There was no change in root sulfur content as a result of fertilization with sulfur bearing potassium sources.

There was a general tendency for N/S ratios of leaf blades and roots to decrease with potassium fertilization when  $K_2SO_4$  and  $KCl + S$  were the sources of potassium. The N/S ratios widened when  $KCl$  was the potassium source.

### Chloride

Root samples taken from Tranquero showed a continuous increase in chloride concentration with increasing rates of potassium applied as  $KCl$  (Table 4). Root samples from plots receiving potassium as  $K_2SO_4$  had relatively stable chloride concentrations at all rates of potassium. Root samples from plots receiving potassium as  $KCl + S$  showed increasing chloride contents with increasing potassium rates but to a lesser extent than those from  $KCl$  plots.

### Discussion

The general superiority of potassium sulfate over potassium chloride as a source of potassium for cassava at both Carimagua and Tranquero was due mainly to the sulfur content of potassium sulfate. The extractable sulfur contents of the soils at both sites were low. At Pance where available sulfur was adequate, there were no differences in growth or yields between plants in plots receiving potassium as potassium chloride and those receiving potassium as potassium sulfate.

In the Campo Cerado of Brazil, where soils have similar characteristics as those encountered at Carimagua and Tranquero, young coffee plants were reported to show sulfur deficiency symptoms during the dry season (Frietas et al. 1972, Lott et al. 1960). These soils had extractable sulfur contents that were generally lower than 3.0 ppm. This is in agreement with the sulfur deficiency symptoms observed at Tranquero during the dry season. The growth and yield differences obtained in this study as a result of sulfur fertilization are in conformity with those obtained by McClung et al. (1959) who used soil from the Campo Cerado in a pot experiment with Pearl Millet as the test crop. They obtained growth responses to sulfur fertilization generally on

soils with available sulfur contents of less than 6.0 ppm. When soil  $SO_4-S$  was greater than 8.0 ppm no growth responses were obtained. The results from the present study also confirm those obtained in a pot experiment with cassava grown on soil from Carimagua (CIAT 1974).

It does appear that induced or aggravated sulfur deficiency caused by an excessive uptake of chloride is one possible explanation for the yield depressions reported in the literature when high rates of potassium, as  $KCl$ , are applied to cassava on soils that are low in sulfur. A toxic effect of the chloride ion per se does not appear to be the cause of these yield depressions nor does it seem to have serious ill effects on carbohydrate accumulation. In the present study, cassava root yields obtained from plots receiving potassium as  $KCl + S$  were equal to those obtained from plots receiving potassium as  $K_2SO_4$  despite the higher chloride content of roots from  $KCl + S$  plots (Table 4).

The great difference between cassava root yields obtained at Pance and those obtained at Tranquero was principally a result of the different ecological conditions encountered at the two sites. At Pance, besides the higher soil fertility status, the climatic conditions were more favourable for plant growth. Rainfall distribution was better than at Tranquero where the plants endured a severe dry season of 3 months. At an altitude of 1000 metres, temperature conditions were more moderate than the 26–27 °C mean annual temperature of the Tranquero area. This would enable more carbohydrates to be accumulated in roots (higher harvest index) at Pance than at Tranquero where respiration would be higher. Thus, although the same cultivar was used at both sites and fertilizer treatments were similar, the greater amount of plant material produced at Pance coupled with a higher harvest index resulted in much higher root yields being produced at Pance than at Tranquero.

The fifth opened leaf from the top appeared to be a reliable sample leaf for detecting changes in the potassium status of cassava plants. The petioles were much more sensitive than leaf blades, and roots were the least sensitive of the plant parts sampled. The suitability of leaf analysis as a basis for making fertilizer recommendations for cassava will be treated in another paper.

Although the sulfur contents of leaf blades and roots were not changed greatly by applying

sulfur bearing potassium sources, the N/S ratios of these plant parts were narrowed considerably. This could mean that there was an increase in the proportion of sulfur bearing amino acids in cassava leaf blade and root protein since most plant sulfur has been reported to be in the protein form (Stewart and Porter 1969). There is need for a more comprehensive investigation on the effects of sulfur fertilization on the nutritional quality of cassava leaf and root protein.

CIAT. *Cassava production systems*. In Annual Report, Centro Internacional de Agricultura Tropical, Cali, Colombia, 1974.

Duncan, A. A. et al. *Effects of potassium chloride and potassium sulfate on yield and quality of sweet potato*. Proc. Amer. Hort. Soc. 71, 1958, 391-398.

Ferguson, T. U., and Haynes, P. H. *The response of yams (Dioscorea spp.) to nitrogen, phosphorus, potassium and organic fertilizer*. Proc. Int. Symp. Trop. Root Crops (Hawaii), 1, 1970, 93-96.

Freitas, L. M. M. de, F. Pimental Gomes, and Lott, W. L. *Effects of sulfur fertilizer on coffee*. IRI Research Institute, Inc., Bull. No. 41, 1972, 24 p.

Itallie, Th. B. van. *Cation equilibria in plants in relation to the soil*. Soil Sci. 65, 1948, 393-416.

Kumar, B. M., Mandal, R. C., and Magoon, M. L. *Influence of potash on cassava*. Ind. J. Agron. 16, 1971, 82-84.

Lott, W. L., McClung, A. C., and Metcalf, J. C. *Sulfur deficiency in coffee*. International Bank for Economic Co-operation, Research Institute Bull. No. 22, 1960, 24 p.

McClung, A. C., Freitas, L. M. M. de, and Lott, W. L. *Analyses of several Brazilian soils in relation to plant responses to sulfur*. Soil Science Society of America Proc. 23(3), 1959, 221-224.

Naderman, G. C. *Yellowing of rice (Oryza sativa L.) as related to root development and mineral nutrition in soils of the Eastern Plains of Colombia*. Ph.D. thesis, Cornell University, Ithaca, N.Y., 1973.

Oke, O. L. *Cassava as a food in Nigeria*. World Rev. Nutr. Diet. 9, 1968, 227-248.

Samuels, G. *The influence of fertilizer levels and sources on cassava production on a lares clay in Puerto Rico*. Proc. Carib. Food Crop Soc. 7, 1970, 33-36.

Stewart, B. A., and Porter, L. K. *Nitrogen-sulfur relationships in wheat (Triticum aestivum L.), corn (Zea mays) and beans (Phaseolus vulgaris)*. Agron. J. 61, 1969, 267-271.

Tabatabai, M. A., and Bremner, J. M. *A simple turbidimetric method of determining sulfur in plant materials*. Agron. J. 62, 1970, 805-806.

## The Interaction of Lime with Minor Elements and Phosphorus in Cassava Production

R. H. Howeler, L. F. Cadavid, and F. A. Calvo<sup>1</sup>

Cassava appears to be a promising food crop for the acid and infertile soils of the Llanos Orientales of Colombia due to its tolerance to soil acidity. Large numbers of varieties have been screened for acid soil tolerance in plots receiving various amounts of lime. Most varieties responded positively to only minor applications of lime while showing a marked negative response to high liming rates. In a lime  $\times$  minor element trial it was shown that liming significantly reduced the uptake of Zn, Mn, Cu, and B and that high liming rates reduced yields by inducing the deficiency of Zn and possibly Mn and B. Cassava appears to have a very high requirement for Zn.

In an experiment studying the effect of lime on P-uptake, cassava responded to P mainly at low liming rates, whereas at high liming rates the response to P was reduced. Thus, liming may improve the availability of soil P and reduce the fixation of applied P. At low liming rates cassava responded markedly to applications as high as 200 kg P<sub>2</sub>O<sub>5</sub>/ha as TSP; the basal application was consistently superior to a split application, while the method of application did not affect yields significantly.

The Eastern Plains (Llanos Orientales) of Colombia are presently underutilized for agri-

cultural production because of extreme soil acidity and infertility. Soils with similar characteristics are found in large areas of the Venezuelan Llanos and the Campo Cerrado of Brazil. Presently they are utilized mainly for

<sup>1</sup>Cassava Soils Program, Centro Internacional de Agricultura Tropical, Cali, Colombia.

sulfur bearing potassium sources, the N/S ratios of these plant parts were narrowed considerably. This could mean that there was an increase in the proportion of sulfur bearing amino acids in cassava leaf blade and root protein since most plant sulfur has been reported to be in the protein form (Stewart and Porter 1969). There is need for a more comprehensive investigation on the effects of sulfur fertilization on the nutritional quality of cassava leaf and root protein.

CIAT. *Cassava production systems*. In Annual Report, Centro Internacional de Agricultura Tropical, Cali, Colombia, 1974.

Duncan, A. A. et al. *Effects of potassium chloride and potassium sulfate on yield and quality of sweet potato*. Proc. Amer. Hort. Soc. 71, 1958, 391-398.

Ferguson, T. U., and Haynes, P. H. *The response of yams (Dioscorea spp.) to nitrogen, phosphorus, potassium and organic fertilizer*. Proc. Int. Symp. Trop. Root Crops (Hawaii), 1, 1970, 93-96.

Freitas, L. M. M. de, F. Pimental Gomes, and Lott, W. L. *Effects of sulfur fertilizer on coffee*. IRI Research Institute, Inc., Bull. No. 41, 1972, 24 p.

Itallie, Th. B. van. *Cation equilibria in plants in relation to the soil*. Soil Sci. 65, 1948, 393-416.

Kumar, B. M., Mandal, R. C., and Magoon, M. L. *Influence of potash on cassava*. Ind. J. Agron. 16, 1971, 82-84.

Lott, W. L., McClung, A. C., and Metcalf, J. C. *Sulfur deficiency in coffee*. International Bank for Economic Co-operation, Research Institute Bull. No. 22, 1960, 24 p.

McClung, A. C., Freitas, L. M. M. de, and Lott, W. L. *Analyses of several Brazilian soils in relation to plant responses to sulfur*. Soil Science Society of America Proc. 23(3), 1959, 221-224.

Naderman, G. C. *Yellowing of rice (Oryza sativa L.) as related to root development and mineral nutrition in soils of the Eastern Plains of Colombia*. Ph.D. thesis, Cornell University, Ithaca, N.Y., 1973.

Oke, O. L. *Cassava as a food in Nigeria*. World Rev. Nutr. Diet. 9, 1968, 227-248.

Samuels, G. *The influence of fertilizer levels and sources on cassava production on a lares clay in Puerto Rico*. Proc. Carib. Food Crop Soc. 7, 1970, 33-36.

Stewart, B. A., and Porter, L. K. *Nitrogen-sulfur relationships in wheat (Triticum aestivum L.), corn (Zea mays) and beans (Phaseolus vulgaris)*. Agron. J. 61, 1969, 267-271.

Tabatabai, M. A., and Bremner, J. M. *A simple turbidimetric method of determining sulfur in plant materials*. Agron. J. 62, 1970, 805-806.

## The Interaction of Lime with Minor Elements and Phosphorus in Cassava Production

R. H. Howeler, L. F. Cadavid, and F. A. Calvo<sup>1</sup>

Cassava appears to be a promising food crop for the acid and infertile soils of the Llanos Orientales of Colombia due to its tolerance to soil acidity. Large numbers of varieties have been screened for acid soil tolerance in plots receiving various amounts of lime. Most varieties responded positively to only minor applications of lime while showing a marked negative response to high liming rates. In a lime  $\times$  minor element trial it was shown that liming significantly reduced the uptake of Zn, Mn, Cu, and B and that high liming rates reduced yields by inducing the deficiency of Zn and possibly Mn and B. Cassava appears to have a very high requirement for Zn.

In an experiment studying the effect of lime on P-uptake, cassava responded to P mainly at low liming rates, whereas at high liming rates the response to P was reduced. Thus, liming may improve the availability of soil P and reduce the fixation of applied P. At low liming rates cassava responded markedly to applications as high as 200 kg P<sub>2</sub>O<sub>5</sub>/ha as TSP; the basal application was consistently superior to a split application, while the method of application did not affect yields significantly.

The Eastern Plains (Llanos Orientales) of Colombia are presently underutilized for agri-

cultural production because of extreme soil acidity and infertility. Soils with similar characteristics are found in large areas of the Venezuelan Llanos and the Campo Cerrado of Brazil. Presently they are utilized mainly for

<sup>1</sup>Cassava Soils Program, Centro Internacional de Agricultura Tropical, Cali, Colombia.

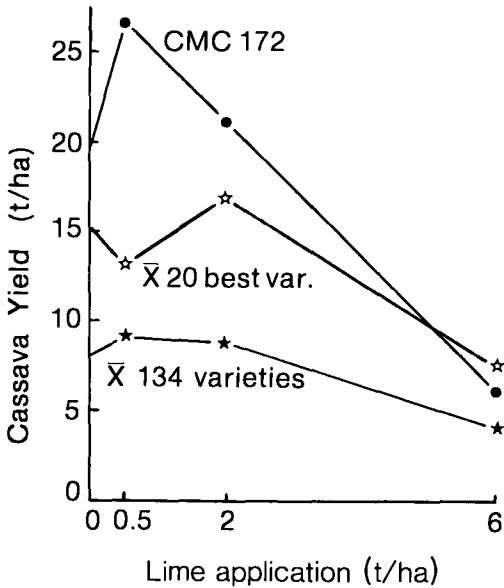

Fig. 1. Effect of liming on the average yield of 134 cassava varieties, the 20 best varieties, and the highest yielding variety CMC 172.

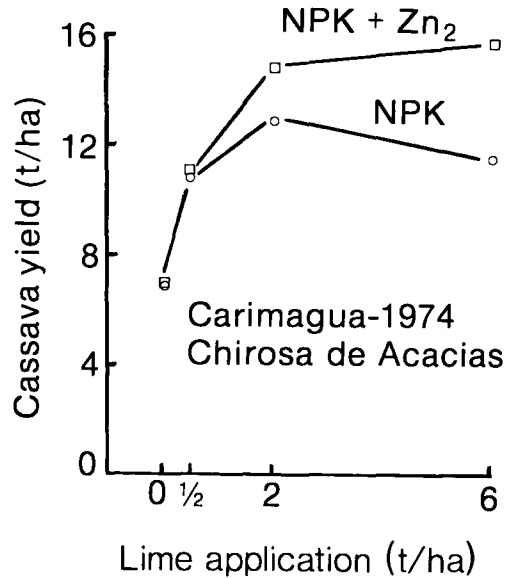

Fig. 2. The response of cassava to lime with and without the application of 20 kg/ha of Zn.

extensive beef production, while small plots of food crops are grown in cut and burned forests that intersect the predominant savannah vegetation. Cassava and plantain are the most commonly grown crops.

During several years of investigation at Carimagua, a research station in the centre of the Llanos, it was found that cassava and cowpea are among the most acid-soil tolerant crops, while corn, sorghum, beans, and several rice varieties are extremely susceptible to soil acidity. The acid-soil tolerance is very important considering the high cost of transportation of lime in an area where roads are nearly nonexistent.

### Materials and Methods

The soils where the experiments were conducted are classified as oxisols (Guerrero 1971), have good internal drainage, and the texture is a clay loam. The soil is extremely acid (pH 4.5), low in P, K, Ca, and Mg, while exchangeable Al occupies about 85% of the effective cation exchange capacity.

#### Experiment I: The Response of 134 Cassava Varieties to Application of Lime

To evaluate the acid-soil tolerance of cas-

sava, a large number of varieties were grown in double rows of 6.25 m length across four plots having lime treatments of 0, 0.5, 2, and 6 t/ha. The lime was applied as a mixture of calcitic limestone and MgO with a milliequivalent Ca:Mg ratio of 10:1. The plots were fertilized with 140 kg N, 100 kg P<sub>2</sub>O<sub>5</sub>, and 200 kg K<sub>2</sub>O/ha as urea, triple superphosphate (TSP), and KCl, respectively. The trial was harvested after 9 months due to disease problems of cassava bacterial blight (CBB) and superelongation.

#### Experiment II: The Interaction of Lime and Minor Elements

To study the effect of lime on minor element availability, the same four lime treatments as described under experiment I were combined with the following minor element treatments in subplots: 10 and 20 kg Zn/ha as zinc sulfate, 10 kg Cu/ha as copper sulfate, 10 kg Mn/ha as manganese sulfate, 2 kg B/ha as R-64, and 200 g Mo/ha as ammonium molybdate. A constant fertilization consisted of 100 kg N, 100 kg P<sub>2</sub>O<sub>5</sub>, and 200 kg K<sub>2</sub>O/ha applied as urea, TSP, and KCl + K<sub>2</sub>SO<sub>4</sub> (1:1), respectively. Chirosa was used as the test variety and harvested at 10 months.

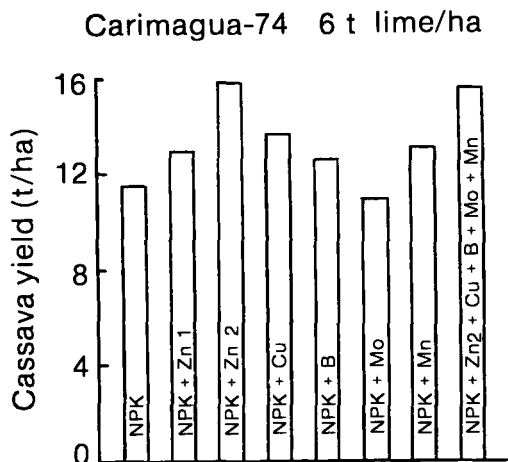

Fig. 3. The response of cassava to the application of minor elements at a liming rate of 6 t/ha.

### Experiment III: The Interaction of Lime and Phosphorus

To study the effect of liming on the response of cassava to P-application, five levels of lime (0, 0.4, 4, 8, 16 t/ha) were combined with three levels of P (0, 50, 100 kg  $P_2O_5$ /ha as TSP) in the subplots. The plots were fertilized with N and K as described in experiment I and harvested after 10 months. Chiroso was used as the test variety.

### Experiment IV: The Effect of Various Levels, Methods, and Time of Application of Phosphorus

Using a split-split plot design, four P levels of 50, 100, 150, and 200 kg  $P_2O_5$ /ha in the main plots were combined with two times of application (100% at seeding and 50% at seeding and 50% at 3 months) in the subplots; three methods of application (broadcast, band, and circle applied TSP) were used in the sub-subplots. Zero-P checks constituted additional treatments. All plots received 0.5 t of lime/ha and 100 kg N and 200 kg  $K_2O$ /ha as urea and  $KCl + K_2SO_4$ , respectively. Llanera was used as the test variety. The trial was harvested after 10 months.

## Results and Discussion

### Experiment I

The application of 0.5 t lime/ha did not have much effect on pH or exchangeable Al

content but was meant mainly to supply Ca and Mg for crop growth. With the application of 6 t lime/ha the pH increased to 5.3 and the Al decreased to 0.8 meq/100 g, a level at which most crops do not suffer from Al toxicity.

Fig. 1 shows the average response to liming of 134 varieties, the best 20 varieties, and the highest yielding variety, CMC 172. Some varieties showed a positive response to 2 t lime/ha, but the majority showed a positive response only to 0.5 t lime/ha with a marked negative response to higher lime applications. At high lime application rates many varieties were stunted and had chlorotic and deformed growing points.

Analyses of the uppermost fully expanded leaves of four varieties showed that liming increased the Ca and Mg contents while decreasing the K, Mn, and Zn contents. Zinc levels were in the deficiency range (< 50 ppm) at all liming rates, but were low enough to result in deficiency symptoms (< 20 ppm) only at the highest liming rate. Thus the problem appeared to be a lime-induced Zn-deficiency.

### Experiment II

Fig. 2 shows the response of the Chiroso variety to liming in the absence and presence of soil-applied Zn. Although yields are rather low due to a CBB attack later in the growing season, it is clear that this variety responded positively to liming up to 2 t/ha in the absence of Zn and up to 6 t/ha in the presence of Zn. The high Zn treatment was the only minor element treatment resulting in a positive response beyond 2 t/ha of lime. This confirms the observation that the yield reduction at high lime levels was due to induced Zn-deficiency. Leaf analyses at 2 months of age again showed that Zn, Mn, Cu, and B levels declined with liming. Zn levels in the absence of soil-applied Zn were relatively high in this variety, but reached deficiency levels at the 6 t lime treatment. No deficiency symptoms were observed. In the presence of 20 kg Zn/ha, Zn content also declined markedly with liming but did not reach the deficiency range even with the highest lime treatment. The yield response due to minor element treatments at the highest lime level indicated that the application of each minor element except Mo increased yields, but only the increase due to the high Zn-treatment was statistically significant (Fig. 3).

A recently established trial of the response of 45 cultivars to liming in the presence of 20

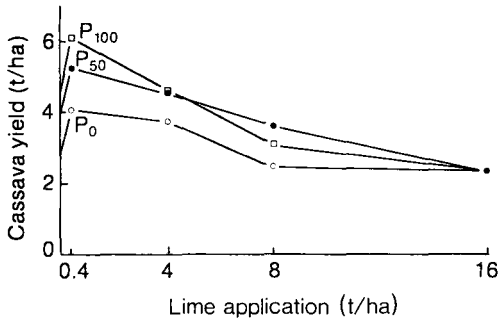

Fig. 4. The response of cassava to the application of lime and phosphorus (numbers on the curves indicate P application rates in kg  $P_2O_5$ /ha).

kg/ha soil-applied Zn showed that the average plant height was positively affected by liming rates up to 6 t/ha. Not one variety showed Zn deficiency symptoms at this lime level. Thus cassava appears to respond positively to liming, like other crops tested, but appears highly susceptible to deficiency of Zn and possibly other minor elements. Still the crop grows well with no or little lime applied in comparison with corn and beans (CIAT 1972).

### Experiment III

Fig. 4 shows the response of the variety Chiroso to lime and phosphorus application. Although yields are low due to disease problems and an early harvest, it is clear that the crop responded positively to only the low lime treatment of 0.4 t/ha with a negative response to higher liming rates. This again is due to lime-induced Zn deficiency.

At the low liming rates there was a clear response to the application of P, while at higher liming rates there was less response to P; at the 16 t/ha lime level there was no P response at all. Liming probably did improve the availability of P, but its effect was confused because of Zn deficiency, which may have been aggravated by the application of P.

### Experiment IV

Fig. 5 shows the response of the Llanera variety to different levels and times of application of P as TSP. There was a marked positive response to levels as high as 200 kg  $P_2O_5$ /ha, but the major response occurred in the first increment with the application of 50 kg  $P_2O_5$ /ha. The basal application of all the P at

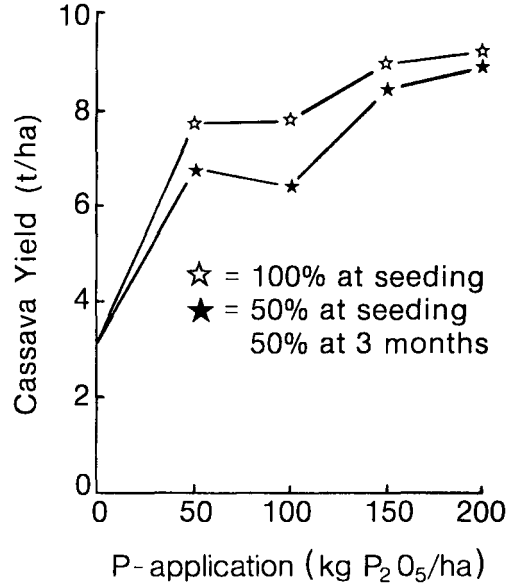

Fig. 5. The response of cassava to five levels and two times of application of P (average of three methods of application).

the time of seeding was consistently superior to the split application at seeding and at 3 months. There were no significant differences among methods of application, i.e. broadcast, band, or circle applied TSP. This is not true, however, for all P-sources. A recent trial, not yet harvested, indicates that the broadcast application of basic slag is highly superior to its band application.

## Conclusions

In acid soils like those of the Llanos Orientales of Colombia many cassava varieties respond to modest liming rates while suffering from minor element (especially Zn) deficiencies at high rates. A positive response to high liming rates could only be obtained in combination with relatively high applications of Zn.

High liming rates appear to reduce the response of cassava to soil applied-P. However, at low liming rates, cassava responded very markedly to levels as high as 200 kg  $P_2O_5$ /ha. Basal application of TSP was superior to its split application, whereas the method of application did not significantly affect yield.

Chacon, O. *Efectos de la cal agricola y el molibdeno sobre el rendimiento de la soya y del mani*. Oriente Agro. 1(1), 1968, 16-22.

CIAT. *Annual Report*. Centro Internacional de Agricultura Tropical (CIAT), Cali, Colombia, 1972, 164.

Guerrero, R. *Soils of the Colombian Llanos Orientales — Composition and classification of selected soil profiles*. Ph.D. thesis, North Carolina State University, Raleigh, North Carolina, 1971.

## Phosphorus Requirement of Three Sweet Potato Cultivars

C. J. Rendle and B. T. Kang<sup>1</sup>

Sweet potato cultivars Tib 3, Tib 4, and Tis 2534 were grown in a Shante soil series at seven levels of phosphorus concentrations in a soil solution ranging from 0.01 to 1.6 ppm P.

Differential response and external P requirement were apparent between the cultivars. At 0.01 ppm P, over 70% of the maximum yield was obtained with the three cultivars. Yields of 95% occurred at 0.05, 0.10, and 0.15 ppm P, respectively, for the cultivars Tib 3, Tib 4, and Tis 2534.

Tissue phosphorus concentrations of 0.22% in the blade and 0.08% in the petiole of the index leaf at 9 weeks after planting appeared to be sufficient for 95% yield for the three cultivars.

The phosphorus response of sweet potato has generally been reported as small or insignificant; however, in some instances, large responses of 50% and above have been observed. Soil data are usually not included in these reports, so meaningful generalization is difficult.

Fox et al. (1974) attempted to determine more generally applicable parameters, basing their experiments on soil solution criteria, rather than on rates of fertilizer applied. They observed that sweet potato yielded 75 and 95% of the maximum yield with 0.003 ppm P and 0.1 ppm P in the soil solution concentration, respectively.

The work presented here uses the soil solution criteria to determine the phosphorus requirement of three sweet potato cultivars in a pot experiment.

### Materials and Methods

The experiment was conducted as a randomized complete block design with three replications. Three sweet potato cultivars Tib 3

(early maturing, relatively low yielding), Tib 4 (intermediate maturing), Tis 2534 (late maturing, high yielding), and 7 external phosphorus concentrations were studied in the experiment.

Twenty kilograms of a Shante soil series (Quartzsipsamment, USDA) was used per pot. The soil has the following properties: loamy sand texture; pH 5.8; Org. C 1.2%; CEC 3.04 meq/100 g; Bray P 3.3 ppm. Phosphorus (finely ground single superphosphate) was applied at planting at rates of 0, 3, 6, 8, 12, 15, and 28 ppm P. These rates were based on the phosphorus absorption isotherm of the soil to provide equilibrium soil solution concentrations of 0.01, 0.025, 0.05, 0.1, 0.2, 0.4, and 1.6 ppm P. Each pot also received before planting 100 ppm N, 10 ppm S, 150 ppm K, and 2 ppm Zn as  $\text{NH}_4\text{NO}_3$ ,  $(\text{NH}_4)_2\text{SO}_4$ , KCl, and  $\text{Na}_2\text{EDTA}$ . A further 25 ppm N as  $\text{NH}_4\text{NO}_3$ , 50 ppm K as  $\text{K}_2\text{SO}_4$ , and 10 ppm Mg as  $\text{MgSO}_4$  were added 10-12 weeks after planting (WAP).

Six plants were planted per pot and watered with deionized water. At 4 WAP plants were staked. One plant was harvested from each pot at 3, 5, 7, and 11 WAP. For each treatment, plants of the three replications were combined, separated in leaf blades, petioles, and stems,

<sup>1</sup>International Institute of Tropical Agriculture, PMB 5320, Ibadan, Nigeria. Part of MSc thesis presented by the senior author, University of Reading, Reading, U.K.

Chacon, O. *Efectos de la cal agricola y el molibdeno sobre el rendimiento de la soya y del mani*. Oriente Agro. 1(1), 1968, 16-22.

CIAT. *Annual Report*. Centro Internacional de Agricultura Tropical (CIAT), Cali, Colombia, 1972, 164.

Guerrero, R. *Soils of the Colombian Llanos Orientales — Composition and classification of selected soil profiles*. Ph.D. thesis, North Carolina State University, Raleigh, North Carolina, 1971.

## Phosphorus Requirement of Three Sweet Potato Cultivars

C. J. Rendle and B. T. Kang<sup>1</sup>

Sweet potato cultivars Tib 3, Tib 4, and Tis 2534 were grown in a Shante soil series at seven levels of phosphorus concentrations in a soil solution ranging from 0.01 to 1.6 ppm P.

Differential response and external P requirement were apparent between the cultivars. At 0.01 ppm P, over 70% of the maximum yield was obtained with the three cultivars. Yields of 95% occurred at 0.05, 0.10, and 0.15 ppm P, respectively, for the cultivars Tib 3, Tib 4, and Tis 2534.

Tissue phosphorus concentrations of 0.22% in the blade and 0.08% in the petiole of the index leaf at 9 weeks after planting appeared to be sufficient for 95% yield for the three cultivars.

The phosphorus response of sweet potato has generally been reported as small or insignificant; however, in some instances, large responses of 50% and above have been observed. Soil data are usually not included in these reports, so meaningful generalization is difficult.

Fox et al. (1974) attempted to determine more generally applicable parameters, basing their experiments on soil solution criteria, rather than on rates of fertilizer applied. They observed that sweet potato yielded 75 and 95% of the maximum yield with 0.003 ppm P and 0.1 ppm P in the soil solution concentration, respectively.

The work presented here uses the soil solution criteria to determine the phosphorus requirement of three sweet potato cultivars in a pot experiment.

### Materials and Methods

The experiment was conducted as a randomized complete block design with three replications. Three sweet potato cultivars Tib 3

(early maturing, relatively low yielding), Tib 4 (intermediate maturing), Tis 2534 (late maturing, high yielding), and 7 external phosphorus concentrations were studied in the experiment.

Twenty kilograms of a Shante soil series (Quartzsipsamment, USDA) was used per pot. The soil has the following properties: loamy sand texture; pH 5.8; Org. C 1.2%; CEC 3.04 meq/100 g; Bray P 3.3 ppm. Phosphorus (finely ground single superphosphate) was applied at planting at rates of 0, 3, 6, 8, 12, 15, and 28 ppm P. These rates were based on the phosphorus absorption isotherm of the soil to provide equilibrium soil solution concentrations of 0.01, 0.025, 0.05, 0.1, 0.2, 0.4, and 1.6 ppm P. Each pot also received before planting 100 ppm N, 10 ppm S, 150 ppm K, and 2 ppm Zn as  $\text{NH}_4\text{NO}_3$ ,  $(\text{NH}_4)_2\text{SO}_4$ , KCl, and  $\text{Na}_2\text{EDTA}$ . A further 25 ppm N as  $\text{NH}_4\text{NO}_3$ , 50 ppm K as  $\text{K}_2\text{SO}_4$ , and 10 ppm Mg as  $\text{MgSO}_4$  were added 10-12 weeks after planting (WAP).

Six plants were planted per pot and watered with deionized water. At 4 WAP plants were staked. One plant was harvested from each pot at 3, 5, 7, and 11 WAP. For each treatment, plants of the three replications were combined, separated in leaf blades, petioles, and stems,

<sup>1</sup>International Institute of Tropical Agriculture, PMB 5320, Ibadan, Nigeria. Part of MSc thesis presented by the senior author, University of Reading, Reading, U.K.

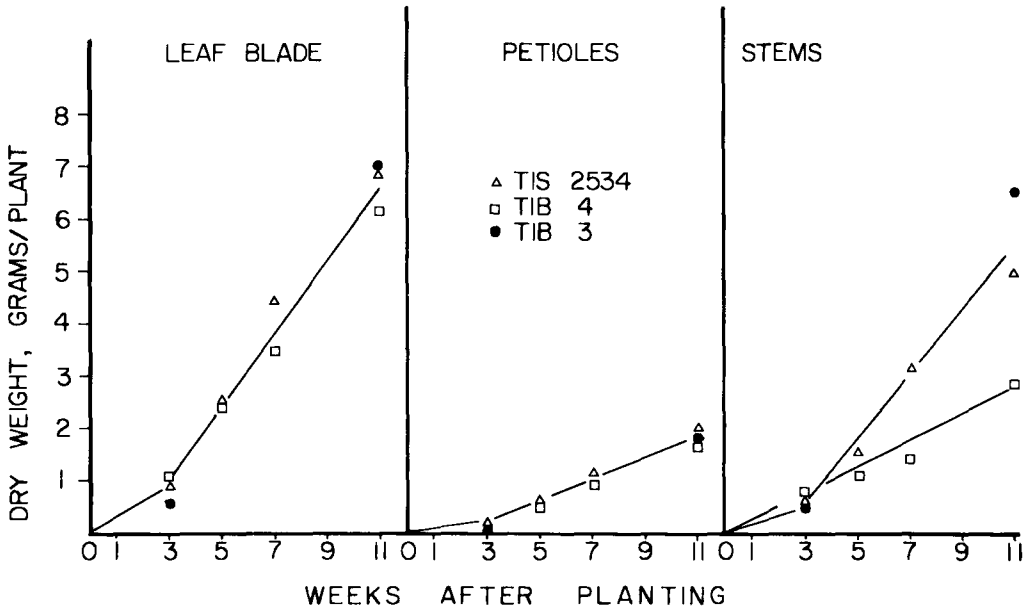

Fig. 1. Average dry matter weight of various plant parts of the three cultivars at various stages of growth.

and dried at 65 °C for dry weight phosphorus determination. At 9 WAP, index leaves consisting of the 4th fully expanded leaf from the top were collected from 8 vines per pot. They were separated in leaf blades and petioles, and dried at 65 °C. The remaining two plants per pot were harvested at 19 WAP. Leaf blades, petioles, stem, and tubers were separated. Sub-samples were taken and dried at 65 °C for dry weight and phosphorus determination.

For phosphorus determination, plant samples were wet digested in a nitric-perchloric acid mixture. The digests were analyzed for phosphorus content using reduced molybdo-vanadate complex.

## Results and Discussion

### Dry Weight of Tops

There appears to be no distinct relationship between the phosphorus treatments and the leaf blade, petiole, and stem weights of the three cultivars sampled at 3, 5, 7, 11, and 19 WAP (data not presented). Although there is a tendency for the dry weight of the plant parts to increase with phosphorus application, no significant differences were observed between

the treatments due to the high variability of the results.

The dry weights of the plant parts as averaged for the various phosphorus treatments are shown in Fig. 1. The dry weights of the leaf blades and petioles and their increases with time are similar for the three cultivars. The lower stem weight of cultivar Tib 4, in comparison with the other two, reflects the shorter growth habit of this cultivar.

### Dry Weight of Tubers

The relationship between external phosphorus concentration and tuber dry weight is shown in Fig. 2. Cultivar Tis 2534 gave the largest response to phosphorus, only 73% of maximum yield was obtained from the control, compared with 78 and 88% for cultivars Tib 4 and Tib 3, respectively. All these responses are relatively low, and are in agreement with the findings of Fox et al. (1974). The 95% yield levels for cultivars Tib 3, Tib 4, and Tis 2534 occur at fertilizer levels designed to give external phosphorus concentrations of 0.05, 0.1, and 0.15 ppm P, respectively.

Although some caution should be exercised in extrapolating these results to field conditions, it seems clear, however, that there are

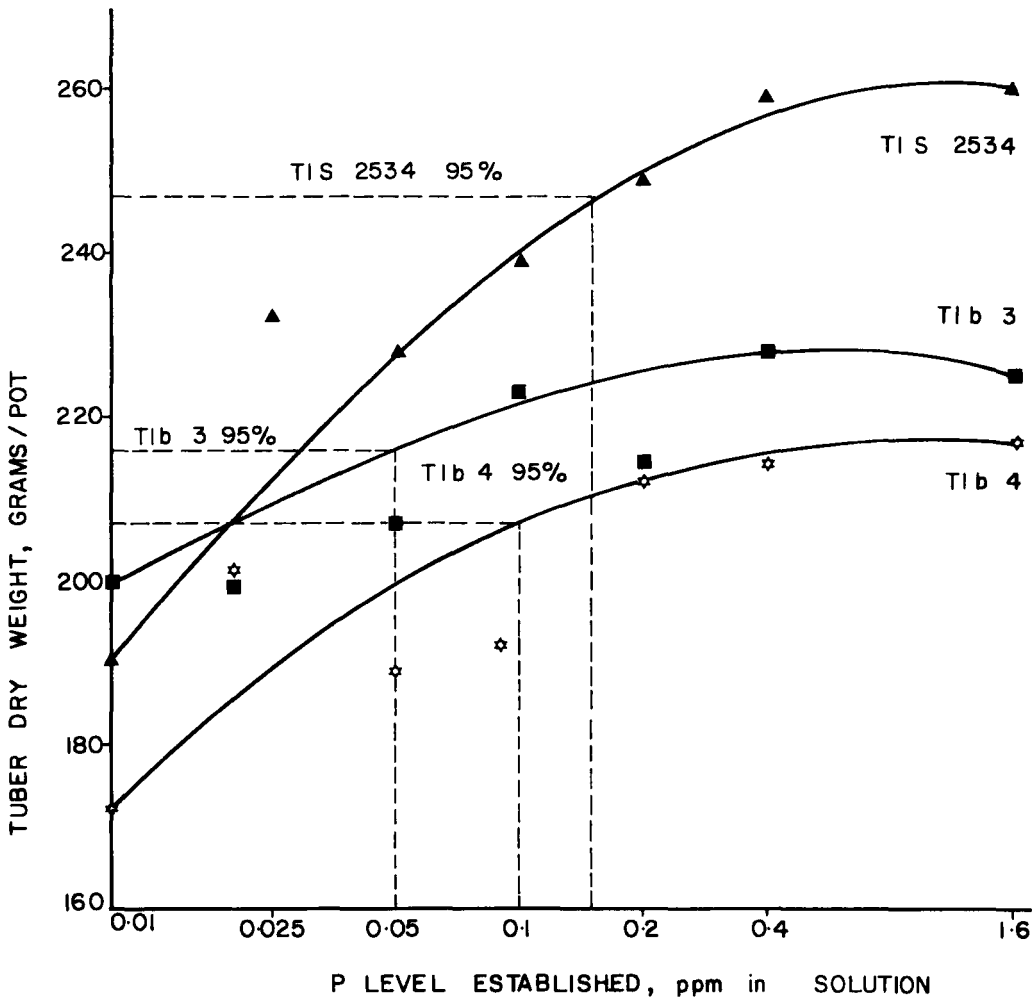

Fig. 2. Relationship between external phosphorus concentration and tuber dry weight of three sweet potato cultivars.

differences in the phosphorus external requirements and responses between the three cultivars. The observed range of soil solution concentrations, required to give 95% yields of 0.05 to 0.15 ppm P, falls close to the 0.1 ppm P level reported by Fox et al. (1974) for field conditions.

**Dry Matter Percentage of Tubers**

There was no significant effect of phosphorus treatment on the dry matter percentage of the tubers. Large differences existed between cultivars. The average dry matter percentage of the early maturing Tib 3 tubers was only

20%, while that of each of the other two cultivars was 30%.

**Phosphorus Concentration in Plant Tissue**

No distinct relationship was observed between the phosphorus content of the leaf blades and petioles at the various harvesting dates for the three cultivars and tuber yield. However, data for phosphorus content for index leaves collected at 9 WAP, shown in Fig. 3 and 4, showed significant relationship with the relative tuber yields as well as with the external phosphorus concentrations. From data presented in Fig. 3 it appears that the phosphorus content

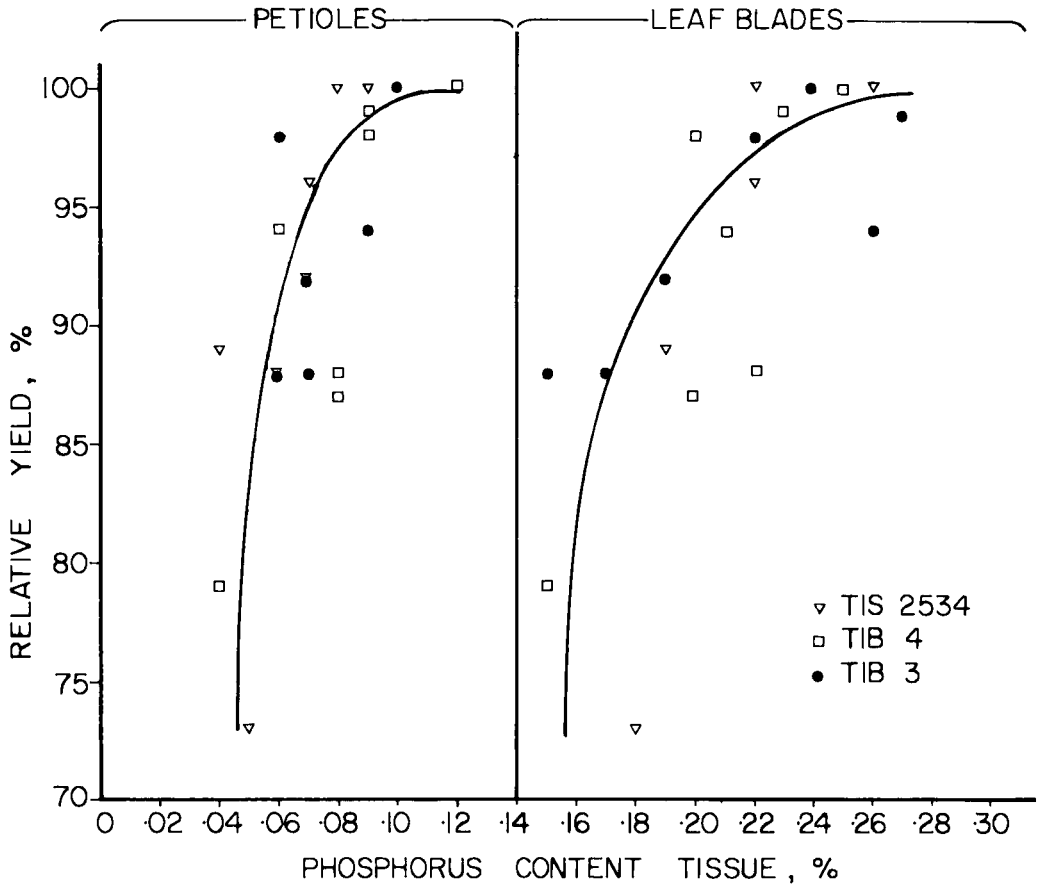

Fig. 3. Relationship between relative tuber yield and phosphorus concentration in petioles and leaf blades of index leaves.

in the petioles is better correlated with tuber yield than with those in the leaf blades. This suggests that petiole phosphorus concentration makes the most useful index. This is also in agreement with results obtained from field trials conducted at IITA (de Groot et al., unpublished data). In general, the phosphorus content of the petioles of cultivar Tis 2534 is lower than those of the other two cultivars for the same external phosphorus concentration indicating that the critical phosphorus concentration in the petiole may be independent of cultivar (Fig. 4). From the data presented in Fig. 3, it is estimated that about 0.08% P in the petiole and about 0.22% P in the leaf blade is sufficient for 95% yield, but these figures may be slightly higher than the critical levels. Spence and Ahmad (1967) quote 0.1% P as the deficiency threshold for sweet po-

tatoes. However, they used whole shoots to the ninth node for their analyses, and their threshold was the appearance of visible deficiency symptoms rather than yield reduction as used here.

## Conclusions

Differential responses to phosphorus were observed among the three cultivars. The responses, however, were relatively small, between 73 and 88% of the maximum yield being obtained in the unfertilized, low phosphorus soil for the three cultivars.

The external phosphorus concentrations required for 95% of the maximum yield were in the range of 0.05–0.15 ppm P, close to the 0.1 ppm P level found by other workers. A level of 0.08% P in the petioles and 0.22% P in the

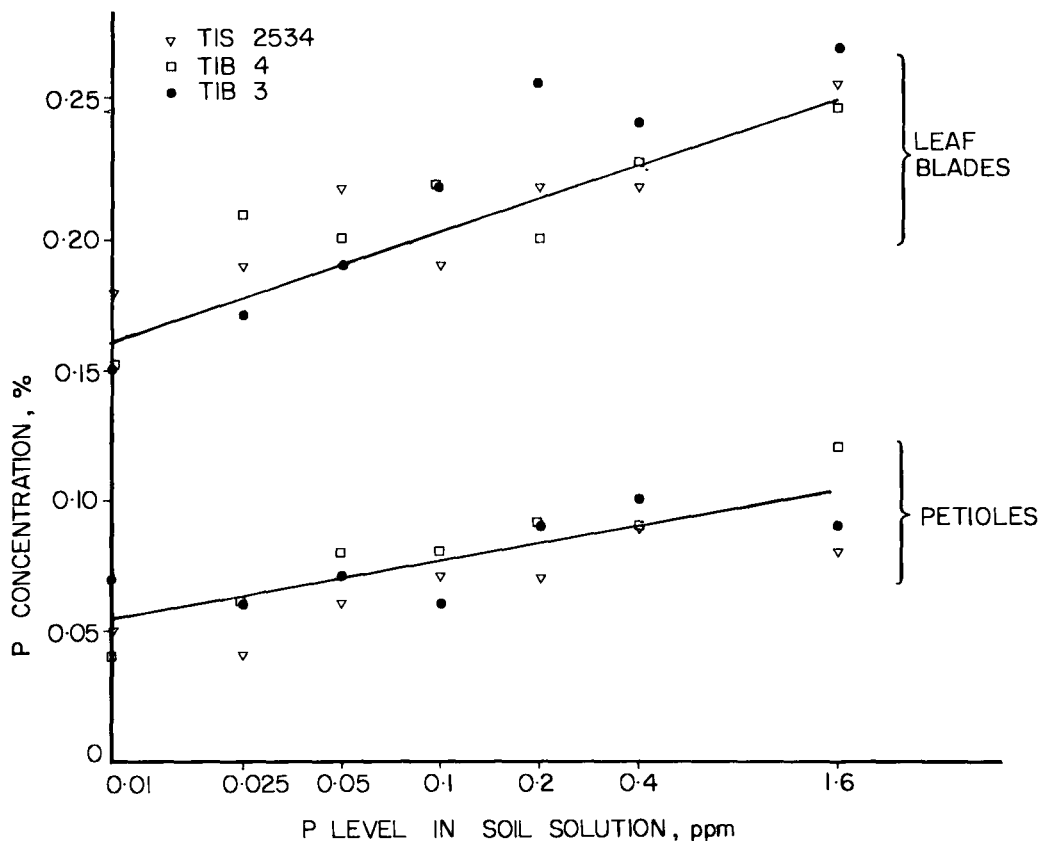

Fig. 4. Relationship between external phosphorus concentrations and phosphorus concentrations in petioles and blades of index leaves.

blades of index leaves at 9 WAP indicates that phosphorus is not limiting, though a slightly lower value may be sufficient. The petiole is suggested as a better index than the leaf blade for monitoring phosphorus status by tissue analysis.

The project was made possible by financial assistance from the International Minerals and Chemical Corporation. The authors also acknowl-

edge the assistance of Dr R. L. Fox for providing the P-sorption isotherm data of the soil.

Fox, R. L., Nishimoto, R. K., Thompson, J. R., and de La Pena, R. S. *Comparative external phosphorus requirements of plants growing in tropical soils*. Trans. 10th Int. Congress Soil Sci., Moscow, IV, 1974, 232-239.

Spence, J. A., and Ahmad, N. *Plant nutrient deficiencies and related tissue composition of the sweet potato*. Agron. J. 59, 1967, 59-62.

## Effect of Farm Yard Manure and NPK on Cassava

C. R. Mohan Kumar, R. C. Mandal, G. M. Nair, and N. Hrish<sup>1</sup>

Exploitation of hybrid vigour in cassava showed the genetic potential for nutrient utilization and improvement of the total biological yield.

Significant tuber yield increases were obtained by the application of farm yard manure in combination with nitrogen, phosphorus, and potash. Farm yard manure with nitrogen, or a combination of nitrogen, phosphorus, and potash were the next best treatments. The lowest tuber yields were recorded in the phosphorus or potash treated plots.

Bitterness of the tuber was increased by the application of farm yard manure and nitrogen, whereas potash reduced it.

Several cassava hybrids evolved at the Central Tuber Crops Research Institute, Trivandrum, have recorded two- to threefold increases in yield compared to the local varieties (Magoon et al. 1970). Cassava is an exhaustive crop, and the soil becomes depleted very quickly by repeated cultivation. Therefore, it is essential to maintain productivity of the soil so that the genetic potential of the hybrids for high yields can be exploited. In a trial conducted with varying levels of farm yard manure (FYM) ranging from 0 to 25 t/ha, the tuber yield increased significantly up to 15 t/ha, but 12.5 t/ha FYM was found to be the optimum. Similarly, testing levels of nitrogen ranging from 0 to 200 kg/ha showed a response to nitrogen up to 125 kg/ha. In another trial conducted with varying levels of potash (0–150 kg K<sub>2</sub>O/ha), tuber yield was significantly increased up to 100 kg K<sub>2</sub>O/ha, beyond which there was a gradual decline in yield. Thus, based on extensive manuring trials, a dose of 12.5 t/ha FYM and NPK at 100 kg/ha was found to be economical for maximizing the yield of promising hybrids (Mandal et al. 1971, 1973; Mohan Kumar et al. 1971). The present investigation was undertaken to determine the response of cassava to FYM and NPK alone and in combination on growth, yield, and quality of cassava.

### Materials and Methods

A replicated manuring experiment was conducted during 1973 and 1974 using the hybrid H-226 on the Institute farm where the soil is an acid laterite. The treatment combinations were as follows: (1) FYM, N,P,K, alone; (2) N + P, N + K, P + K, and N + P + K; (3)

FYM plus either N, P, K, NP, NK, PK, or NPK; and (4) control (no manure).

Farm yard manure (12.5 t/ha) and NPK (100 kg/ha) each were applied in respective treatments. Planting was during May/June and harvesting during February/March (10 months after planting).

Observations on plant height and number of leaves produced and retained per plant were taken at different stages of growth. Data on number of tubers per plant, mean size of tubers, and the tuber yield (t/ha) were recorded at harvest. Qualitative characteristics like carbohydrate content, HCN content, and cooking quality of tubers were analyzed by standard methods.

### Results and Discussion

The observations on plant height, total number of leaves produced per plant, and the number of leaves retained were taken during growth and at maturity.

#### Plant Height

Application of nitrogen alone or in combination with P and K significantly increased plant height. Further significant increase in height was achieved by the addition of FYM. However, application of K and P alone or in combination reduced height considerably (Fig. 1).

#### Leaf Production and Retention

Maximum leaf production (319 per plant) and retention (64 per plant) were observed in treatment FYM + NPK. The effect of N alone and in combination with P or K was also pronounced, whereas the application of K alone recorded the lowest leaf production (214 per plant) i.e. 33% reduction over FYM + NPK (Fig 2a, b).

<sup>1</sup>Central Tuber Crops Research Institute, Trivandrum, 695017, India.

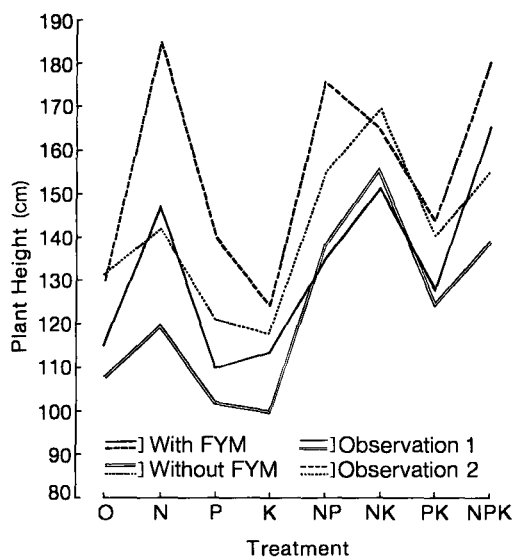

Fig. 1. Influence of various treatments on plant height.

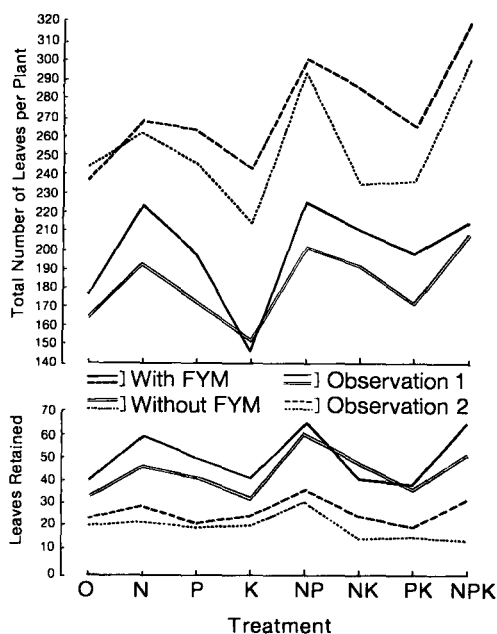

Fig. 2. Influence of various treatments on (A) total number of leaves per plant and (B) number of leaves retained per plant.

### Tuber Yield, Size, and Number

The mean tuber yield, tuber size, and tuber number per plant are presented in Table 1. It is clear that N alone or in combination with P or K has a significant effect on tuber yield. Similar trends were observed in the case of tuber size, which agrees with the reports of Singh et al. (1973) in *Dioscorea alata*. A significant effect of K on production of more tubers was also observed (Table 1). The enhancement of tuber production with the application of K was recorded by Dean (1971) for sweet potato. However, the treatment FYM (12.5 t/ha) + NPK (100 kg/ha) gave a significant increase in yield over other treatments.

### HCN and Starch Content of Tuber

The data on tuber analyses (Table 2) reveal that the HCN content of the tubers was increased in treatments FYM, N, and FYM + N, whereas the starch content of the tubers showed an increasing trend with the application of potash. Similar observations of increased levels of HCN in cassava tubers with FYM application were recorded by Thomas Kurien et al. (1975).

### Cooking Quality of Tuber

Organoleptic tests on cooked tubers indi-

Table 1. Tuber yield (t/ha), tuber size (g), and tuber number/plant.

	O/FYM	N	P	K	NP	KK	PK	NPK	S.E.
<b>Tuber yield (t/ha)</b>									
Without FYM	15.8	18.7	17.0	15.2	19.7	22.4	18.1	24.0	±0.655
With FYM	18.6	24.4	18.6	18.2	24.1	23.2	21.6	27.1	±1.84
<b>Tuber size (g)</b>									
Without FYM	187	235	205	170	262	253	184	276	±8.94
With FYM	220	299	233	206	294	295	240	294	±25.10
<b>Tuber no./plant</b>									
Without FYM	5.02	5.04	5.31	5.63	5.64	6.19	6.15	6.27	±0.227
With FYM	5.52	5.78	5.61	6.05	5.97	6.31	6.57	6.87	±0.638

Table 2. Effect of FYM and NPK on HCN and starch content of tubers.

	O/FYM	N	P	K	NP	NK	PK	NPK	S.E.
HCN ( $\mu\text{g/g}$ )									
Without FYM	103	175	98	68	158	105	75	98	$\pm 2.34$
With FYM	113	180	120	85	173	135	85	120	$\pm 6.75$
Starch content (%)									
Without FYM	25.7	24.0	25.8	26.4	24.3	26.3	27.7	25.1	$\pm 0.49$
With FYM	25.1	25.0	25.4	26.7	24.7	27.7	27.9	25.4	$\pm 1.41$

cated that N alone or FYM + N gave a bitter taste and a harder texture. On the other hand, K alone or P + K gave a nonbitter taste and a softer texture.

It may be concluded that though nitrogen significantly increased the tuber yield, it considerably affected cooking quality, particularly taste. However, the addition of P + K to N improved the quality.

The authors are thankful to Smt K. R. Lakshmi for helping in statistical analysis of the data and to Shri C. S. Antonisamy for preparing the graphs.

Dean, E. Knavel. *The influence of nitrogen and potassium nutrition on vine and root development of the 'All Gold' sweet potato at early stages of storage root enlargement.* J. Amer. Soc. Hort. Sci. 96(6), 1971, 718-720.

Magoon, M. L., Appan, S. G., Krishnan, R., and

Mandal, R. C. *Some promising high yielding hybrids and selections of cassava.* SABRAO Newsletter, 2(1), 1970, 19-26.

Mandal, R. C., Singh, K. D., and Magoon, M. L. *Relative efficacy of different sources, levels and split application of nitrogen in tapioca.* Indian J. Agro. 16(4), 1971, 449-452.

Mandal, R. C., Singh, K. D., and Maini, S. B. *Effect of plant density, fertilizer level and shoot number on tuber yield and quality of tapioca hybrids.* Indian J. Agron. 18(4), 1973, 498-503.

Mohan Kumar, B., Mandal, R. C., and Magoon, M. L. *Influence of potash on cassava.* Indian J. Agron. 16(1), 1971, 81-84.

Singh, K. D., Mandal, R. C., and Maini, S. B. *A note on effect of nitrogen levels on tuber yield and quality of Dioscorea alata.* Indian J. Agron. 18(1), 1973.

Thomas Kuriyan, Maini, S. B., Indira, P., and Rajendran, N. *Regulation of the levels of cynogenic glucosides in cassava.* National Symp. on Root Crops, Trivandrum, India, Sept. 1975.

## Mineral Nutrition of Cassava and Adaptation to Low Fertility Conditions

D. G. Edwards, C. J. Asher, and G. L. Wilson<sup>1</sup>

In experiments using solution culture techniques, cassava was shown to be more tolerant than maize and soybean to low pH and high levels of aluminium and manganese. The requirements for potassium, nitrogen, and calcium for maximum growth are comparable to other crops. In the case of phosphorus, the needs are higher than other crops. Nevertheless the data show that cassava tolerates low calcium, nitrogen, and potassium in the root zone better than other crops. The plant has an ability to bulk roots at low phosphorus levels.

Cassava has earned a reputation for being well adapted to soils of low fertility. Thus, the

<sup>1</sup>Department of Agriculture, University of Queensland, St. Lucia, Queensland 4067, Australia (D. A. Forno, G. A. Gunatillika, A. K. M. S. Islam, S. Jintanon, C. E. Lee, and S. N. Spear contributed to the research program).

ability of cassava to produce some yield, albeit low, in subsistence agriculture systems on soils of low fertility status has contributed greatly to its success over other staple food crops. Despite claims that cassava cultivars adapted to low soil fertility conditions show reduced ability to respond to fertilizer application, the results of

Table 2. Effect of FYM and NPK on HCN and starch content of tubers.

	O/FYM	N	P	K	NP	NK	PK	NPK	S.E.
HCN ( $\mu\text{g/g}$ )									
Without FYM	103	175	98	68	158	105	75	98	$\pm 2.34$
With FYM	113	180	120	85	173	135	85	120	$\pm 6.75$
Starch content (%)									
Without FYM	25.7	24.0	25.8	26.4	24.3	26.3	27.7	25.1	$\pm 0.49$
With FYM	25.1	25.0	25.4	26.7	24.7	27.7	27.9	25.4	$\pm 1.41$

cated that N alone or FYM + N gave a bitter taste and a harder texture. On the other hand, K alone or P + K gave a nonbitter taste and a softer texture.

It may be concluded that though nitrogen significantly increased the tuber yield, it considerably affected cooking quality, particularly taste. However, the addition of P + K to N improved the quality.

The authors are thankful to Smt K. R. Lakshmi for helping in statistical analysis of the data and to Shri C. S. Antonisamy for preparing the graphs.

Dean, E. Knavel. *The influence of nitrogen and potassium nutrition on vine and root development of the 'All Gold' sweet potato at early stages of storage root enlargement.* J. Amer. Soc. Hort. Sci. 96(6), 1971, 718-720.

Magoon, M. L., Appan, S. G., Krishnan, R., and

Mandal, R. C. *Some promising high yielding hybrids and selections of cassava.* SABRAO Newsletter, 2(1), 1970, 19-26.

Mandal, R. C., Singh, K. D., and Magoon, M. L. *Relative efficacy of different sources, levels and split application of nitrogen in tapioca.* Indian J. Agro. 16(4), 1971, 449-452.

Mandal, R. C., Singh, K. D., and Maini, S. B. *Effect of plant density, fertilizer level and shoot number on tuber yield and quality of tapioca hybrids.* Indian J. Agron. 18(4), 1973, 498-503.

Mohan Kumar, B., Mandal, R. C., and Magoon, M. L. *Influence of potash on cassava.* Indian J. Agron. 16(1), 1971, 81-84.

Singh, K. D., Mandal, R. C., and Maini, S. B. *A note on effect of nitrogen levels on tuber yield and quality of Dioscorea alata.* Indian J. Agron. 18(1), 1973.

Thomas Kuriyan, Maini, S. B., Indira, P., and Rajendran, N. *Regulation of the levels of cynogenic glucocides in cassava.* National Symp. on Root Crops, Trivandrum, India, Sept. 1975.

## Mineral Nutrition of Cassava and Adaptation to Low Fertility Conditions

D. G. Edwards, C. J. Asher, and G. L. Wilson<sup>1</sup>

In experiments using solution culture techniques, cassava was shown to be more tolerant than maize and soybean to low pH and high levels of aluminium and manganese. The requirements for potassium, nitrogen, and calcium for maximum growth are comparable to other crops. In the case of phosphorus, the needs are higher than other crops. Nevertheless the data show that cassava tolerates low calcium, nitrogen, and potassium in the root zone better than other crops. The plant has an ability to bulk roots at low phosphorus levels.

Cassava has earned a reputation for being well adapted to soils of low fertility. Thus, the

<sup>1</sup>Department of Agriculture, University of Queensland, St. Lucia, Queensland 4067, Australia (D. A. Forno, G. A. Gunatillika, A. K. M. S. Islam, S. Jintanon, C. E. Lee, and S. N. Spear contributed to the research program).

ability of cassava to produce some yield, albeit low, in subsistence agriculture systems on soils of low fertility status has contributed greatly to its success over other staple food crops. Despite claims that cassava cultivars adapted to low soil fertility conditions show reduced ability to respond to fertilizer application, the results of

many experiments show that cassava yields in low fertility areas can be raised substantially through improved crop nutrition. Jacoby (1965) reported strong differences among cultivars in responsiveness to fertilizer application, whereas Spain et al. (1974) found large differences in fresh root yields of cassava cultivars grown at four different lime rates.

The major soils used for cassava production in Latin America, Africa, and Southeast Asia are moderately to strongly acid oxisols and ultisols located in the tropics. In addition to their inherently low fertility, many of these soils exhibit limited production potential because of acid soil infertility. Problems of low pH, aluminium and manganese toxicities, molybdenum and calcium deficiencies, and low phosphorus and potassium availability have been reviewed recently (Kamprath and Foy 1971, Pearson 1975). Results from liming experiments have indicated that large genetic differences in acid soil tolerance exist among cassava cultivars (Spain et al. 1974).

Work conducted at the University of Queensland during the past 5 years has been particularly directed toward understanding the nature of the adaptation of cassava to low fertility situations. In addition, physiological differences between cultivars in nutrient response have been studied using stem tip cuttings raised using a mist propagation procedure. Substantial effort has also been directed toward recording and describing symptoms of nutritional disorders of cassava.

## Methods

Most of this work was conducted in dilute continuously flowing solution cultures. Use of this technique allows plants to be grown under conditions in which the root environment is closely defined with respect to temperature, pH, and nutrient ion concentrations. In as much as the solution concentration does not decrease with time as a result of plant uptake the system is analogous to that of a well-buffered soil (Loneragan 1968). Using this technique, experiments have been conducted to compare the effects of a range of constant solution pH's and constant concentrations of Al, K, Ca,  $\text{NO}_3$ ,  $\text{NH}_4$ , and P on the growth of cassava and other selected species. Interest has centered upon the nature of the response curves, both in terms of plant growth and nutrient absorption. Of particular significance,

however, are the solution concentrations at which the growth of cassava and other species are restricted, with or without any symptom expression.

In current work, attempts are being made to test the conclusions from flowing culture experiments on cassava and other species using a highly buffered soil that has been adjusted to a wide range of equilibrium soil solution concentrations.

In an experiment on root bulking, plants were grown in large pots of nutrient solution (22 l) to which frequent small additions of phosphorus were made to ensure the plants either had a nonlimiting supply of the element throughout the experiment or were subject continuously to moderate or severe phosphorus stress. This technique referred to as "programmed nutrient addition" has been used successfully with other crops (Asher and Cowie 1970).

In still other experiments, conventional solution culture techniques employing small volumes (2.2 l) of relatively concentrated nutrient solution (e.g. Hoagland-Arnon solution) have been used in the study of nutrient deficiency and toxicity symptoms and in establishing critical tissue nutrient concentrations for the growth of cassava.

## Results

### Response to Solution pH

Effects of solution pH ranging from 3.3 to 8.5 on the relative whole plant yields of cassava (cv. Nina), maize, and tomato are shown in Fig. 1. This experiment was conducted in the flowing solution culture units with pH automatically controlled to within  $\pm 0.1$  pH of the designated value and with the concentrations of all essential elements maintained at adequate levels. All species were grown for 4 weeks before harvest. The pH optimum of cassava is quite normal, at about 5.5. However, more significant is the higher relative yield of cassava at the lowest solution pH values.

These results suggest that cassava possesses a greater tolerance to high hydrogen ion concentration per se (low pH) than either tomato or maize.

### Response to Solution Aluminium Concentrations

Cassava, maize, and soybean were grown in flowing solution culture at six aluminium concentrations ranging from 0 to 160  $\mu\text{M}$ . The

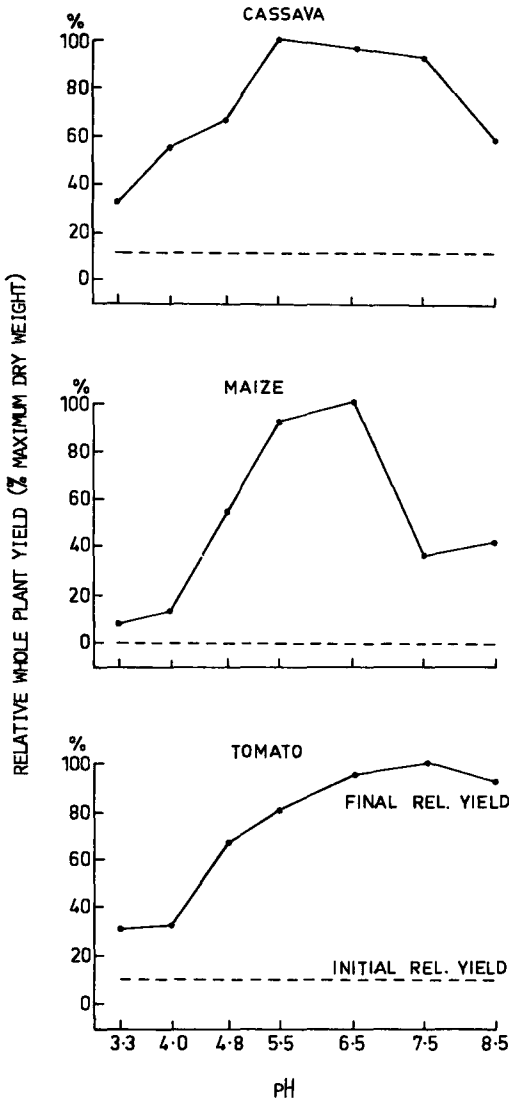

Fig. 1. Effect of nutrient solution pH on relative yield of cassava, maize, and tomato.

solution pH was maintained at  $4.2 \pm 0.1$  for the duration of the experiment. The response curves indicate that cassava is, on average, more tolerant to high solution aluminium concentrations than either maize or soybean (Fig. 2). At high solution aluminium, no obvious symptoms of root injury were exhibited by any of the cassava cultivars, whereas the roots of both maize and soybean showed severe injury symptoms, notably stunted and irregular lateral root development.

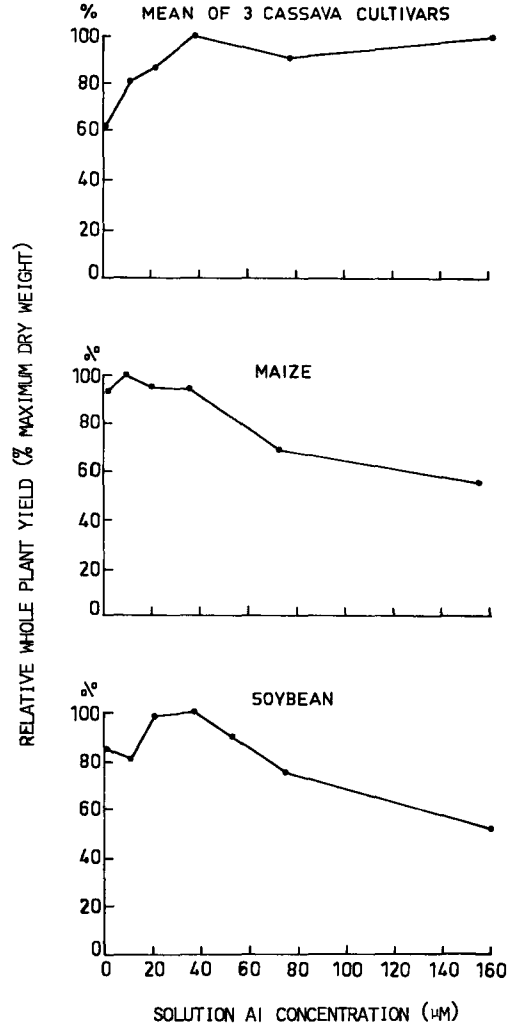

Fig. 2. Relative dry matter yield of whole plants as a function of concentrations of aluminium in solution.

However, considerable variation in yield response to aluminium was found to exist among the three cassava cultivars studied. Cultivar CUQ2 achieved maximum yield at the highest aluminium concentration, while cultivar CUQ5 showed considerable sensitivity to the higher aluminium concentrations. All three cultivars showed a positive yield response to low concentrations of aluminium. The mechanism responsible for this effect is not known despite a previous report of this effect in pasture legumes tolerant to high solution aluminium concentrations (Andrew et al. 1973).

Table 1. External solution concentrations ( $\mu\text{mol/litre}$ ) of potassium, calcium, nitrogen (ammonium and nitrate forms), and phosphorus required for maximal growth of cassava and four other crops.

	Element (or ion)				
	K	Ca	NH <sub>4</sub>	NO <sub>3</sub>	P
Cassava					
lowest conc.	8(9) <sup>a</sup>	101(2) <sup>b</sup>	7(1)	525(3)	50(6)
highest conc.	125(3)	—	489(5)	5100(8)	127(6)
Soybean	—	1035	—	—	0.7
Maize	8	3	7	52	3
Sorghum	—	10	489	525	—
Sunflower	32	101	29	525	—

<sup>a</sup>Figures in brackets indicate number of cultivars reaching maximal growth at the specified concentration.

<sup>b</sup>Both cultivars reached maximum yield at the same concentration.

The results obtained indicate that cassava cultivars show a range of adaptation to high solution aluminium concentrations, with one cultivar showing behaviour similar to the poorly tolerant maize and soybean, whereas the other two cultivars were much more highly tolerant.

### Manganese Toxicity

No detailed studies of the tolerance of cassava cultivars to manganese toxicity have yet been made. However, a recent conventional solution culture experiment with a single cultivar CUQ2 suggests that very high external manganese concentrations ( $> 2000 \mu\text{M}$ ) may be needed to cause recognizable symptoms and appreciable inhibition of growth. This growth inhibition was associated with a dramatic increase in manganese concentration in the plant and the development of a very pronounced interveinal chlorosis in the younger leaves. The failure of Howell (1974) to obtain symptoms of manganese toxicity other than temporary leaf wilting on hot days may have been due to an insufficient concentration of manganese ( $1000 \mu\text{M}$ ) in the culture medium.

These results imply that cassava may be well adapted to those acid soils in which manganese toxicity limits the growth of other crop species. More detailed studies are required to confirm this suggestion.

Table 2. Relative yield of cassava and other crop species at the lowest constant solution concentrations ( $\mu\text{M}$ ) used in various flowing culture experiments.

	Element (or ion)				
	K (0.5)	Ca (0.5)	NH <sub>4</sub> (0.4)	NO <sub>3</sub> (0.4)	P (0.05)
Cassava					
mean	52	26 <sup>a</sup>	40	20	18
range	32–71	—	29–55	14–27	12–26
Soybean	—	2	—	—	34
Maize	36	2	7	6	21
Sorghum	—	3	5	2	—
Sunflower	43	0.2	9	3	—

<sup>a</sup>Relative yield the same for each of the two cultivars studied.

### External Solution Concentrations for Maximal Growth

The external solution concentrations of potassium, calcium, nitrogen (ammonium and nitrate forms), and phosphorus required at the plant root surfaces for maximal growth of cassava and four other crop species are presented in Table 1. These data were obtained from a series of flowing solution culture experiments in which the solution pH was held constant (usually at  $6.0 \pm 0.1$ ) throughout the duration of the experiment. The number of cassava cultivars used in the individual experiments ranged from 2 in the calcium experiment to 12 in the potassium and phosphorus experiments.

For potassium, calcium, and ammonium nitrogen, the external concentrations needed for maximal yields of the cassava cultivars are roughly comparable with those required for maximal yields of the other species studied. However, for nitrate nitrogen and in particular for phosphorus, in general higher external concentrations were needed to achieve maximal growth of cassava than for the other crop species. Thus, in the case of nitrate, eight of the eleven cultivars only reached maximal yield at the highest concentration studied ( $5100 \mu\text{M}$ ), whereas none of the other crop species required more than  $525 \mu\text{M}$  for maximal yield (Table 1). In the case of phosphorus, the contrast between cassava and the other crops was even greater. Indeed, the concentrations needed for maximal growth ( $50$ – $127 \mu\text{M}$ ) are higher than those of any other species reported in the literature (Asher and Loneragan 1967) with the possible exception of potato (Houghland 1947).

Table 3. Concentrations of individual elements in the plant tops at the lowest continuously maintained solution concentrations ( $\mu\text{M}$ ). Plant concentrations are expressed on a g/100 g dry weight basis.

	Element (or ion)				
	K (0.5)	Ca (0.5)	N(NH <sub>4</sub> ) (0.4)	N(NO <sub>3</sub> ) (0.4)	P (0.05)
Cassava mean	0.68	0.23	1.30	1.38	0.08
range	0.58–0.82	0.10–0.35	n.a.	n.a.	0.06–0.11
Soybean	—	n.d.	—	—	0.13
Maize	0.89	0.23	0.70	1.20	0.10
Sorghum	—	0.11	1.10	1.10	—
Sunflower	1.04	n.d.	0.90	1.10	—

NOTE: n.a. — not available; n.d. — not determined, insufficient material.

The much higher solution requirements for phosphorus and nitrate exhibited by cassava suggest that, for maximum growth, cassava may require even higher levels of soil fertility than other common crop species.

#### Ability to Grow at Low External Nutrient Concentrations

The relative dry matter yields of cassava and four other crop species grown in flowing solution culture at the lowest solution concentrations tested for potassium, calcium, nitrogen (ammonium and nitrate), and phosphorus are presented in Table 2. For calcium and both forms of nitrogen, cassava was outstanding in its ability to grow under external nutrient concentration conditions that drastically limited the growth of the other species. For example, a solution calcium concentration of  $0.5 \mu\text{M}$  reduced the yields of the other four crops to from 0.2 to 3% of maximum, whereas both cassava cultivars studied were able to achieve 26% of maximum yield in this treatment. In the case of potassium, where the deficiencies were not so severe in the other crops, cassava achieved a generally higher relative yield. However, cassava did not appear to possess any special advantage over the other species at the lowest phosphorus concentration.

These data provide clear evidence that cassava is able to tolerate low calcium, nitrogen, and potassium in the root environment better than the other species. This adaptation could well be of considerable significance in the success of cassava in low fertility field situations.

#### Tissue Concentrations at Lowest Solution Concentrations

The concentrations of potassium, calcium, nitrogen, and phosphorus in the plant tops at the lowest continuously maintained solution concentrations in the various individual flowing culture experiments are presented in Table 3. The mean concentrations of potassium and phosphorus were lower in cassava than in the other crop species, while the mean concentrations of nitrogen were higher than those in the other species. These concentration differences between cassava and the other species in themselves provide no evidence for adaptation to low fertility conditions. However, comparison of the plant tissue concentration data with the yield data (Table 2) does provide a means for assessing how efficiently the various nutrient elements are utilized in dry matter production by cassava and the other species. This comparison provides evidence for an adaptation of cassava to low fertility conditions with respect of both potassium and nitrogen, but not phosphorus. Thus, the association of lower potassium concentrations in the tops of cassava (Table 3) with higher relative yields (Table 2) suggests an adaptation in that cassava utilizes potassium more efficiently in dry matter production than the other species. The association of somewhat higher nitrogen concentrations in the tops of cassava than other species with the very much greater relative yields of cassava than other species also suggests a more efficient utilization of nitrogen in dry matter production by cassava. By contrast, the association of lower phosphorus concentrations in the

Table 4. Minimum nutrient concentrations in the tops of cassava and four other crop species at which plants were completely free of deficiency symptoms. Concentrations in g/100 g dry weight.

	K	Ca	P
Cassava			
mean	2.13	0.41	0.11
range	1.04-3.23	0.29-0.53	0.09-0.15
Soybean	—	2.70	0.22
Maize	4.30	0.20	0.42
Sorghum	—	0.38	—
Sunflower	6.91	1.97	—

tops of cassava with lower relative yields does not provide any evidence of adaptation. No trends are discernible in the case of calcium because of insufficient data.

### Symptomless Growth Reduction

The minimum nutrient concentrations in the tops of cassava and other crop species at which plants were totally free of potassium, calcium, and phosphorus deficiency symptoms are shown in Table 4. Cassava was free of phosphorus and potassium deficiency symptoms at substantially lower plant tissue concentrations than other species. In the case of calcium, the concentrations necessary in cassava tops to prevent the development of symptoms were above those of the monocotyledons maize and sorghum, but well below those of the dicotyledons sunflower and soybean. In the case of phosphorus, all species were generally free of symptoms at the same solution concentration, viz. 0.7  $\mu\text{M}$  phosphorus (Jintakanon, pers. comm.). At this concentration, the relative yield of cassava and also the phosphorus concentration in the tops of cassava were less than in soybean and maize. The apparent ability of cassava to regulate its growth under low solution phosphorus concentrations is believed to represent a further mechanism of adaptation to low soil fertility conditions.

The various studies have demonstrated that cassava tends to retain its older leaves on the plant to a much greater degree than other species when a nutrient stress is imposed. Spear et al. (1976) have observed much smaller differences in potassium concentration between the older leaves of cassava than other species when grown at adequate and limiting solution potassium concentrations.

In addition, Spear et al. (1976) observed

comparatively little decline in potassium concentration with age in the leaves of cassava plants grown at the lowest solution potassium concentration (0.5  $\mu\text{M}$ ), whereas both maize and sunflower exhibited a strong gradient in declining leaf potassium concentration with increasing leaf age. Forno (pers. comm.) also observed that the oldest one or two leaves remained dark green compared with younger leaves when cassava was grown at very low external nitrogen concentrations (0.4  $\mu\text{M}$ ). These observations suggest that cassava possesses an abnormally low phloem mobility when compared with the other crop species. They also suggest an adaptation to low fertility conditions in that under sustained, but low nutrient supply cassava can adjust its rates of growth downward to match the low rates of nutrient uptake, thereby obviating the need for remobilization of nutrients from older leaves.

### Effects of Phosphorus Stress on Root Bulking

All the experiments discussed so far have been of short-term duration and never more than 4 weeks. Accordingly, no consideration has been given to the production of the major harvestable part of the plant, viz. the large, swollen roots, under conditions where a particular nutrient stress is applied.

A longer term solution culture experiment using the programmed nutrient approach (Asher and Cowie 1970) referred to earlier was conducted with the objective of determining the effect of a continuously maintained phosphorus stress on root bulking in cassava. Bulking was markedly reduced by phosphorus stress. However, stress effects on root bulking were much less than stress effects on the production of plant tops. At the final harvest on day 108, moderate and severe phosphorus stress resulted in relative top dry matter yields of 62 and 27% respectively, while the comparable relative yields of swollen roots were 76 and 44%, respectively. A comparison of the yield of thickened roots with top yields suggests that the severely stressed plants were considerably more efficient in that they produced a greater yield of swollen roots per unit weight of plant tops than the control plants, even though the absolute yield of roots was less. This compensation represents another adaptive mechanism that may explain some of the success of cassava in low fertility soils.

No phosphorus deficiency symptoms were observed on the severely stressed cassava plants until the closing stages of the experiment despite the 73% reduction in the yield of tops. In fact, in the absence of the nonstressed control and the moderately stressed plants, no basis would exist for believing that the growth of the severely stressed plants was anything other than normal. This ability to match growth rate to nutrient supply may well be important in the success of cassava in low fertility soils, but also makes it difficult, in the absence of phosphorus rate experiments, to establish just how deficient a crop really is under actual field conditions.

### Conclusions

Several features that may be associated with the special adaptation of cassava to low fertility situations, including high soil acidity, have been identified. These include the ability to maintain relative yields under low nitrogen, potassium, and calcium, the more efficient utilization of potassium and nitrogen in dry matter production, and the ability to regulate its growth under low nutrient supply conditions. This latter feature is strengthened by the abnormally low phloem mobility of some elements that these studies suggest are characteristic of cassava. The ability to proceed with root bulking under quite severe phosphorus stress may be another important feature in the success of cassava as a crop plant in poor soils. Evidence is also presented that tolerance to low pH per se, to high aluminium concentrations, and possibly to high manganese are features of importance in the adaptation of at least some cultivars to highly acid soils. They suggest explanations for the large differences in acid soil tolerance among cassava cultivars reported by Spain et al. (1974).

Any advantages that cassava may possess by virtue of the vertical or horizontal distribution of roots in low fertility soils would not be revealed in solution culture studies such as those described here. Furthermore, any special mechanisms that cassava may possess for

solubilizing soil constituents, e.g. through an alteration of rhizosphere pH or redox potential, through excretion of chelates, or through mycorrhizal associations, would not be of significance in the solution culture studies. These aspects also require investigation.

Andrew, C. S., Johnson, A. D., and Sandland, R. L. *Effect of aluminium on the growth and chemical composition of some tropical and temperate pasture legumes*. Aust. J. Agric. Res. 24, 1973, 325-339.

Asher, C. J., and Loneragan, J. F. *Response of plants to phosphate concentration in solution culture. I. Growth and phosphorus content*. Soil Sci. 103, 1967, 225-233.

Asher, C. J., and Cowie, A. M. *Programmed nutrient addition — a simple method for controlling the nutrient status of plants*. Aust. Plant Nutrition Conf., Mt. Gambier, 1 (b), 1970, 28-32.

Houghland, G. V. C. *Minimum phosphate requirement of potato plants grown in solution culture*. J. Agric. Res. 75, 1947, 1-18.

Howell, D. H. *Symptoms of nutrient deficiency in cassava (Manihot esculenta Crantz)*. M.Sc. thesis, Univ. Guelph, Guelph, Canada, 1974.

Jacoby, T. *Nutrition and manuring of root crops*. Verlagsgesellschaft für Ackerbau, Mbh, Hanover, Green Bull. No. 19, 1965, 9-16.

Kamprath, E. J., and Foy, C. D. *Lime-fertilizer-plant interactions in acid soils*. In Olson, R. A., Army, T. J., Hanway, J. J., and Kilmer, V. J., eds., *Fertilizer technology and use*. 2nd Edition, Soil Sci. Soc. Amer., Madison, Wisc., 1971, 105-151.

Loneragan, J. F. *Nutrient concentration, nutrient flux, and plant growth*. Trans. 9th Int. Congr. Soil Sci., Adelaide, 2, 1968, 173-182.

Pearson, R. W. *Soil acidity and liming in the humid tropics*. Cornell Int. Agric. Bull. 30, 1975.

Spain, J. M., Francis, C. A., Howeler, R. W., and Calvo, F. *Differential species and varietal tolerance to soil acidity*. Proc. Sem. Soil Management and Development Process Trop. Amer. 1974 (in press).

Spear, S. N., Asher, C. J., Edwards, D. G., and Wilson, G. L. *Response of cassava (Manihot esculenta Crantz) to potassium concentration in solution. I. Growth and plant potassium concentration*. 1976 (in press).

## Characteristics of Indigenous and Introduced Cultivars of Cassava in Guyana

A. H. Wahab<sup>1</sup>

A yield trial was conducted for 12 months to assess the performance of 12 varieties of cassava on Guyana's agriculturally poor but extensive peats and peaty soils. On the peats, the four high yielding varieties, M. Mexico 59, M. Mexico 23, Del Pais, and M. Colombia 673 gave fresh yields of 30.5, 19.3, 19.3, and 18.2 t/ha, respectively. On the peaty clays, high yielding varieties were M. Mexico 59, Uncle Mack, Del Pais, and M. Mexico 23 with yields of 23.1, 22.1, 20.0, and 17.6 t/ha, respectively. The lowest yielding varieties on both soils were Chinese stick (7.6 t/ha on the peats and 9.0 t/ha on the peaty clay) and Bitterstick, which produced 11.7 t/ha on the peats and 9.0 t/ha on the peaty clay.

Plant height and shooting and branching patterns were not related to yield, but harvest index was correlated with yield on both soils. Useful matter (ratio of peeled/unpeeled root) was not significantly different between varieties on both soils.

Immediately to the south of Guyana's Coastal plain lie approximately one million hectares of undrained peats, peaty clays, and muck soil. Many of the peat swamps and marshes are used to provide water for irrigation and for domestic and industrial uses. Native vegetation on these soils consists mostly of swamp forest, but freshwater marsh is found in some places. The peat is locally called "pegasse" and when it merges with the clays it is referred to as "pegassy clay".

Peat or muck soils are marginal for conventional agriculture, however viable cultivation of these marginal peaty soils could be of value to Guyana's expansionist agricultural program. Cassava appears to be a promising crop for these marginal soils as it is: (1) adapted to poor soils; (2) relatively resistant to weeds and insect pests; (3) best suited to light soils for root production; and (4) is not season-bound. Additionally, efforts are underway to transform cassava from a traditional back yard crop to one of agroindustrial importance.

The performance of 12 indigenous and introduced cultivars of cassava was evaluated on these drained peats and peaty clays.

### Materials and Methods

#### Soils

Field trials were conducted on two soil types (pH 3-4), locally classified as Anira peat No. 20, and Inki Clay No. 100 (Steele and Ramdin 1975). The Anira peat consists of dark reddish

brown peat from the surface (0-15 cm) and varies from raw to semidecomposed peat-peaty clay. Hydrogen sulfide is present from 0 to 122 cm. This peat has a high swell/shrink ratio (50% or greater) and may be ignited when dry (Mahadeo 1975). Inki clay consists of a surface matt of 1-20 cm of peaty clay. The upper subsoil is a soft gray to greenish gray clay that is underlined by peat (Mahadeo 1975).

Trials were conducted south of Enmore Sugar Estate from April 1975 to April 1976. The two areas were naturally inundated until early 1974 when the necessary drainage facilities were installed. Following drainage, the areas were cleared of weeds, underlying logs, and timber. Land preparation consisted of ploughing and rotovation. In-field drains (12 m apart, 0.5 m deep) were excavated and connected to a drainage canal. Soils were sampled at 0-15 cm and 15-30 cm for determination of physicochemical properties. Samples were taken at planting and following harvest (12 months later) to monitor soil chemical characteristics.

#### Varieties and Experimental Design

A total of 12 varieties were used. Of these, seven (Brancha butterstick, Bitterstick, Chinese stick, Four month, R. Singh, Twelve month, and Uncle Mack) were believed to be indigenous to Guyana, one (Del Pais) was introduced from Puerto Rico, and the others (Llanera, M. Colombia 673, M. Mexico 23, and M. Mexico 59) were promising varieties from CIAT's collection. Planting material for eight varieties was obtained from 6 to 9 month

<sup>1</sup>Guyana Sugar Corporation Limited, Georgetown, Guyana.

Table 1. Physicochemical characteristics at the time of planting of the two soils used to compare the 12 cassava cultivars.

	Anira peat No. 20	Inki clay No. 100
Field capacity of plow layer (%)	299	59
Bulk density (g/cm <sup>3</sup> )		
0-15 cm	0.2	0.9
15-30 cm	0.2	0.9
pH		
0-15 cm	3.7	4.2
15-30 cm	3.6	4.1
Total soluble salts (ppm)		
0-15 cm	861	647
15-30 cm	932	830
Cation exchange capacity (meq/100 g)		
0-15 cm	18.2	15.5
15-30 cm	22.3	16.8
Al (meq/100 g) <sup>a</sup>		
0-15 cm	7.4	8.6
15-30 cm	7.4	8.1
Ca (meq/100 g)		
0-15 cm	4.4	3.0
15-30 cm	3.6	2.6
Mg (meq/100 g)		
0-15 cm	5.3	3.4
15-30 cm	8.0	5.4
K (meq/100 g)		
0-15 cm	0.5	0.3
15-30 cm	0.4	0.3
P (ppm) Truog		
0-15 cm	37.5	1.5
15-30 cm	15.3	0.8
N (%)		
0-15 cm	1.5	0.5
15-30 cm	1.4	0.4
Organic matter (%)		
0-15 cm	31.4	8.1
15-30 cm	33.5	7.1

<sup>a</sup>Ca, Mg, and Al were determined using *N*KCl extract, K was determined using 0.5*N* CH<sub>3</sub>COOH extract.

old plants. These plants were established in the field nursery from two-node stem cuttings following CIAT's rapid multiplication method. Planting material of the remaining four varieties (Bitterstick, Chinese stick, R. Singh, and Twelve month) were obtained from 12 to 15 month old plants made available by the Central Agricultural Station, Mon Repos. A completely randomized 5 replicate trial was used. Plots (9.1 × 4.6 m, 0.004 ha) were planted in 5

rows of 10 plants each. All observations were made on 15-20 test plants taken from two central rows. Rows 1 and 5 were buffer rows. Where insufficient planting material was available the planting density (11955 plants/ha) was kept constant by planting other varieties in the buffer rows.

### Planting, Soil Amelioration, and Subsequent Management

Planting material (15 cm long) was machine cut, immersed in a suspension of Dithane-M-45 (0.04% a.i.) and monocrotophos (0.06% a.i.) for 0.5 h, and planted inclined in furrows 8-10 cm deep. Both trial sites were planted in late April 1975 within 2 days of each other, just prior to the long rainy season.

Lime was applied in the form of 6.7 t/ha of aragonite 1 month after sowing. Fertilizers were applied at rates of 198 kg N (urea), 67 kg P<sub>2</sub>O<sub>5</sub>, and 134 kg K<sub>2</sub>O/ha. One-half of the fertilizer was applied with the lime, one-quarter 3 months, and the balance 5 months after planting. Each application was banded circularly 15 cm away from the plant and incorporated 4-5 cm. To correct apparent copper and zinc deficiencies, 14 kg CuSO<sub>4</sub> and 12 kg ZnSO<sub>4</sub>/ha were applied at 5 months as well as a prophylactic dose of 22 kg/ha of fritted trace elements.

Plots were manually weeded 1, 4, and 9 months after planting. Serious outbreaks of hornworm (*Erynnis ello*) were observed at both sites following heavy and continuous showers in September, October, November, and December. After the crop became infested for a second time, fortnightly applications of monocrotophos (0.5 liter a.i./ha) were made, resulting in effective control. Moderately severe attacks of shoot fly (*Silba pendula*) were observed from the ninth month and persisted through harvest. Trichlorfon (Dipterex) at 1 kg a.i./ha at 3-week intervals controlled this pest.

## Results

### Soil Properties

Some physicochemical characteristics of the two soils are presented in Table 1. Both soils were extremely acidic, and pH was not ameliorated following lime application. Water holding capacity of the Anira peat (300%) greatly exceeded that of the Inki clay (58%). Conversely, bulk densities of the Anira peat

Table 2. Germination and plant height data for cassava variety trials.<sup>a</sup>

Variety	Anira peat No. 20		Inki clay No. 100	
	Germination at 60 days (%)	Plant height at harvest (cm)	Germination at 60 days (%)	Plant height at harvest (cm)
Brancha butterstick	96.0 <sup>ns</sup>	170.0 <sup>e</sup>	94.8 <sup>ns</sup>	198.0 <sup>e</sup>
M. Mexico 23	98.4	139.0 <sup>c</sup>	97.6	163.0 <sup>abcd</sup>
Bitterstick	92.4	216.0 <sup>g</sup>	96.4	201.0 <sup>e</sup>
Chinese stick	95.6	153.0 <sup>d</sup>	98.0	183.0 <sup>de</sup>
Del Pais	98.8	154.0 <sup>d</sup>	98.4	168.0 <sup>abcd</sup>
Four month	97.6	124.0 <sup>b</sup>	99.6	165.0 <sup>abcd</sup>
Llanera	91.6	120.0 <sup>ab</sup>	94.4	162.0 <sup>abc</sup>
M. Colombia 673	94.8	154.0 <sup>d</sup>	98.8	148.0 <sup>a</sup>
M. Mexico 59	93.2	167.0 <sup>e</sup>	94.0	181.0 <sup>cde</sup>
R. Singh	88.8	115.0 <sup>a</sup>	92.0	169.0 <sup>bcd</sup>
Twelve month	90.0	180.0 <sup>f</sup>	92.4	205.0 <sup>f</sup>
Uncle Mack	98.8	136.0 <sup>c</sup>	98.4	158.0 <sup>ab</sup>
Grand mean	95.0	152.2	96.0	178.6
S.E.	—	1.83	—	6.37
C.V. (%)	—	2.7	—	8.0

<sup>a</sup>Values followed by the same letter do not differ significantly ( $p = 0.05$ ), ns = no significant difference within column.

(0.24) were about one-fourth those of the Inki clay (0.94). The total soluble salts were low in both soils at planting, but had increased slightly at harvest within the 15–30 cm Anira peat layer and throughout the 0–30 cm soil depth in the Inki clay.

There were a greater number of exchangeable sites on the Anira peat than there were on the Inki clay. Exchangeable aluminum was fairly high for both soil types. Phosphorus levels were low in both soils and remained unchanged at harvest. Anira peat plots contained very high total nitrogen throughout the 0–30 cm soil depth, whereas nitrogen within the Inki clays was lower but adequate for plant growth. Potassium levels in both soils were adequate and showed an increase at harvest.

As would be expected, organic matter was much higher in the Anira peat than on the Inki clay. Ratios of C/N were optimal for the peats at the time of planting and became less favourable following cultivation. This situation was somewhat reversed in the clays where a more favourable C/N ratio was obtained following cultivation.

### Germination and Growth Characteristics

Data on germination and plant height at harvest are presented in Table 2. Indigenous varieties germinated faster than the introduced

ones; however, at 60 days all varieties germinated equally well on both soils. Plant heights were not significantly different between soils up to 70 days. Thereafter, all plants on the Inki clay grew taller than on the Anira Peat. On both soils Bitterstick and Twelve month grew tallest and were the most vigorous. Throughout the trial, varietal differences in plant height were statistically significant. Except for Del Pais, all the other introduced varieties produced one main stem per cutting on both soil types. Most of the local variety produced two main stems on one or both soils.

Distances from the soil surface to the first branching point on the main stem varied significantly among varieties. There was a tendency for early branching in the varieties Four month, Llanera, and M. Colombia 673. All varieties had at least two branches attached to the main shoot and several indigenous varieties produced three. Stem diameter at the first branch differed significantly among varieties on both soils. Indigenous varieties had the thinnest stems on both soils; plants on the Inki clay had larger stem diameters than those grown on the Anira peat.

### Fresh Root Yields

Fresh weight data are presented in Table 3. Root yields were significantly different between

Table 3. Yields (fresh roots, t/ha) of 12 cassava varieties (11955 plants/ha) at 12 months on two agriculturally poor soils in Guyana.<sup>a</sup>

Variety	Anira peat No. 20	Inki clay No. 100
M. Mexico 59	30.5 <sup>e</sup>	23.1 <sup>f</sup>
M. Mexico 23	19.3 <sup>d</sup>	17.6 <sup>cdef</sup>
Del Pais	19.3 <sup>cd</sup>	20.0 <sup>def</sup>
M. Colombia 673	18.2 <sup>bcd</sup>	16.5 <sup>bcd</sup>
Twelve month	16.4 <sup>bcd</sup>	12.4 <sup>abcd</sup>
Llanera	15.3 <sup>bcd</sup>	16.9 <sup>bcd</sup>
Uncle Mack	15.2 <sup>bcd</sup>	22.1 <sup>ef</sup>
Brancha butterstick	14.2 <sup>abcd</sup>	15.3 <sup>bcd</sup>
R. Singh	13.0 <sup>abcd</sup>	14.7 <sup>bcd</sup>
Four month	12.1 <sup>abc</sup>	17.4 <sup>bcd</sup>
Bitterstick	11.7 <sup>ab</sup>	11.1 <sup>abc</sup>
Chinese stick	7.6 <sup>a</sup>	9.0 <sup>ab</sup>
Grand mean	16.1	16.3
S.E.	2.2	2.0
C.V. (%)	29.5	26.8

<sup>a</sup>Values followed by the same letter do not differ significantly ( $p = 0.05$ ).

varieties on both soil types. There was a wider spread (7.6–30.5 t/ha) in root fresh matter on the Anira peat than there was on the Inki clay (9.0–23.1 t/ha). Three of the five introduced varieties yielded worse and five of the seven indigenous varieties better on the Inki clay than on the Anira peat. Chinese stick yielded lowest on both soils. M. Mexico 59 produced significantly higher yields (30.5 t/ha) than all the other varieties grown on the Anira peat. It also ranked highest (23.1 t/ha) on the Inki clay but was not significantly better than Uncle Mack, which produced 22.1 t/ha. Except for Four month, M. Mexico 23, M. Colombia 673, Twelve month, and Uncle Mack all the other varieties ranked similarly on both soils. Uncle Mack rose from seventh place (15.2 t/ha) on the Anira peat to second on the Inki clay.

#### Dry Matter, Total and Useful Yield, Harvest Index, and Root Density

Values for some of these parameters are shown in Table 4. Root dry matter was significantly different between varieties in both soil types. Values ranged from 29 to 37% for the Anira peat and from 28 to 42% for the Inki clay. Highest producers of dry matter were M. Mexico 59 (9.0 t/ha) and Uncle Mack (7.6

t/ha). These varieties produced almost four times as much dry matter as Chinese stick. Total fresh matter production was significantly different between varieties irrespective of soil type. However, there was a greater concentration of fresh matter in the shoots, stems, and leaves of plants on the Anira peat. Total fresh matter ranged from 19 to 41 t/ha for the Anira peat and 24 to 39 t/ha on the Inki clay. Again, M. Mexico 59 produced the highest amount of total fresh matter on the Anira peat, whereas Del Pais was the highest on Inki clay.

Useful root fresh matter content averaged 85% and did not vary significantly between varieties on either soil. Consequently, those varieties that had produced highest fresh root yields, e.g. M. Mexico 59, Del Pais, and Uncle Mack, also produced highest amounts of useful fresh matter.

Harvest index values were significantly different between varieties in either soil type. Values were consistently higher for any one variety grown on the Anira peat versus that same variety grown on the other soil.

Root densities were essentially the same (1.094) on the Anira peat. However, values were significantly different between varieties on the Inki clay. On this soil, Four Month and Brancha butterstick produced roots having lowest (1.066) and highest (1.160) densities.

Number of root tubers per plant differed significantly between varieties on both soils. Also, root proliferation in the Inki clay exceeded that in the Anira peat, for each variety. Root tubers per plant ranged from 5 to 9 for the Anira peat, and 7 to 15 for the Inki clay.

Weights of tubers from plants grown in the Anira peat were consistently higher than for plants grown on the Inki clay. Average weight per root tuber per plant ranged from 155 to 352 g for the Anira peat and 84 to 223 g for the Inki clay.

Root tuber length differed significantly between varieties on each soil. Longest root lengths were exhibited by Brancha butterstick measuring 44 cm on the Anira peat and 54 cm on the Inki clay. Shortest root tuber length was also significantly different between varieties and on each soil type. Chinese stick produced the shortest roots irrespective of the soil. Observations on length of the median root indicated that 50% or more of the root tubers of Brancha butterstick measured 22 cm on the Anira peat and 29 cm on the Inki clay. Corresponding values for M. Mexico 59 were 26

Table 4. Results of variety trials on Anira peat No. 20 and Inki clay No. 100 after 12 months.

Variety	Anira peat No. 20			Inki clay No. 100		
	Equivalent root yield (t/ha) fresh matter	Equivalent total plant fresh weight (t/ha)	Equivalent yield (t/ha) of useful fresh matter	Equivalent root yield (t/ha) fresh matter	Equivalent total plant fresh weight (t/ha)	Equivalent yield (t/ha) of useful fresh matter
<b>Brancha</b>						
butterstick	14.2 <sup>abcd</sup>	21.7 <sup>ab</sup>	12.1 <sup>abc</sup>	15.3 <sup>bcd</sup>	30.6 <sup>abc</sup>	12.8 <sup>bed</sup>
M. Mexico 23	19.3 <sup>d</sup>	27.3 <sup>abcd</sup>	16.6 <sup>bc</sup>	17.6 <sup>cdef</sup>	27.9 <sup>ab</sup>	15.1 <sup>cdef</sup>
Bitterstick	11.7 <sup>ab</sup>	25.1 <sup>abcd</sup>	10.4 <sup>ab</sup>	11.1 <sup>ab</sup>	32.9 <sup>abcd</sup>	9.2 <sup>ab</sup>
Chinese stick	7.6 <sup>a</sup>	22.6 <sup>abc</sup>	6.7 <sup>a</sup>	9.0	26.8 <sup>a</sup>	7.7 <sup>a</sup>
Del Pais	19.3 <sup>cd</sup>	30.5 <sup>cd</sup>	16.8 <sup>c</sup>	20.0 <sup>def</sup>	38.7 <sup>d</sup>	17.2 <sup>def</sup>
Four month	12.1 <sup>abc</sup>	22.5 <sup>a</sup>	10.6 <sup>abc</sup>	17.4 <sup>bcdef</sup>	33.6 <sup>abcd</sup>	15.0 <sup>cdef</sup>
Llanera	15.3 <sup>bed</sup>	19.3 <sup>a</sup>	13.0 <sup>bc</sup>	16.9 <sup>bcdef</sup>	29.5 <sup>abc</sup>	14.6 <sup>cdef</sup>
M. Colombia 673	18.2 <sup>bed</sup>	28.9 <sup>bed</sup>	15.8 <sup>bc</sup>	16.5 <sup>bcd</sup>	29.4 <sup>abc</sup>	14.1 <sup>bcd</sup>
M. Mexico 59	30.5 <sup>e</sup>	41.4 <sup>e</sup>	24.8 <sup>d</sup>	23.1 <sup>f</sup>	36.1 <sup>cd</sup>	19.3 <sup>f</sup>
R. Singh	13.0 <sup>abcd</sup>	19.1 <sup>a</sup>	10.5 <sup>abc</sup>	14.7 <sup>abcd</sup>	27.6 <sup>ab</sup>	12.5 <sup>abcd</sup>
Twelve month	16.4 <sup>bed</sup>	31.1 <sup>d</sup>	14.0 <sup>bc</sup>	12.4 <sup>abc</sup>	30.4 <sup>abc</sup>	10.7 <sup>abc</sup>
Uncle Mack	15.2 <sup>bed</sup>	22.6 <sup>abc</sup>	12.7 <sup>abc</sup>	22.1 <sup>ef</sup>	35.4 <sup>bcd</sup>	18.5 <sup>ef</sup>
<b>Grand mean</b>	16.1	26.0	13.7	16.3	31.6	13.9
<b>S.E.</b>	2.2	3.6	1.9	2.0	3.4	0.16
<b>C.V. (%)</b>	29.5	21.8	30.8	26.8	17.0	25.0

<sup>a</sup>Values followed by the same letter do not differ significantly ( $p = 0.05$ ).

cm for the Anira peat and 19 cm for the Inki clay.

Maximum root diameter measurements indicated that root thickness differed significantly between varieties on either soil type. On both soils, root diameter of Brancha butterstick was lowest, whereas M. Mexico 59 produced roots of highest maximum diameter.

An examination of rooting depth pattern showed that the maximum depth of root penetration on the Anira peat was 15 cm, whereas with the exception of Llanera, R. Singh, and Twelve month all other varieties on the Inki clay penetrated to a maximum depth of 30 cm.

### Postharvest Storage Life

On both soils, with the exception of M. Colombia 673 all varieties stored for at least 5 days before vascular streaking was noticed (Table 5). M. Mexico 59 harvested from the Anira peat stored longer (10 days) than all other varieties. However, this variety when harvested from the Inki clay showed vascular streaking at 5 days. Secondary deterioration of roots occurred at 10 and 11 days on the Anira peat and Inki clay, respectively. Storage lives

were not consistent for a given variety harvested from both soils.

### Discussion

Total rainfall experienced (331 cm) during the trial period exceeded the 105 year average (210 cm) for Enmore Estate by 58% and can be described as adverse for Guyana conditions. Rain fell 62% of the trial days, and on 34 days (10%) precipitation exceeded 2.5 cm. Months of lowest rainfall (15 cm or less) were August through September 1975 and March 1976; and heavy rains fell from November through February (156 cm). In other words, during germination and stand establishment, and presumably during maximum root bulking, the crop experienced excessive moisture. Also, during the trial period, bright sunshine averaged just 6.5 h/day, which considered separately might have been detrimental to yield.

Soil properties at planting and following harvest indicated high buffering capacities in both soils. This is consistent with the percentage of base saturation observed for the Anira peat

Table 5. Time (days) to onset of primary<sup>a</sup> and secondary<sup>b</sup> root deterioration of 12 cassava cultivars stored under ambient conditions.<sup>c</sup>

Variety	Anira peat No. 20		Inki clay No. 100	
	Primary deterioration	Secondary deterioration	Primary deterioration	Secondary deterioration
M. Mexico 59	10	11	6	10
Brancha butterstick	7	8	8	11
Chinese stick	7	12	6	10
Twelve month	7	10	9	11
M. Mexico 23	5	12	5	8
Bitterstick	5	11	6	8
Del Pais	5	11	6	10
Llanera	5	11	7	11
R. Singh	5	11	8	11
Four month	5	9	6	10
Uncle Mack	5	8	9	12
M. Colombia 673	4	5	5	10
Grand mean	5.7	10	6.8	11

<sup>a</sup>Primary deterioration was considered to have started with the appearance of fine blue-black streaks in the root vascular tissue.

<sup>b</sup>Secondary deterioration was considered to have occurred when the root tissues became soft.

<sup>c</sup>Storage conditions: Anira peat 7.15–83 °F, R.H. 78.3%; Inki clay 74.4–84.5 °F, R.H. 83%.

(50%) and Inki clay (40%). Indeed, the addition of lime (6.72 t/ha) did not ameliorate soil pH. Further, available phosphorus levels were low and decreased at harvest. This is probably due to the high fixation of this nutrient, which occurs at low pH values.

Yield figures indicated that despite the unfavourable climatic conditions that prevailed, the agriculturally poor peats and peaty clays produced average yields of 16 t/ha. Recalling the serious outbreaks of hornworm and shoot fly that were experienced, it is possible that these pests coupled with the unfavourable climate depressed yields. M. Mexico 59 yielded significantly higher (30.5 t/ha) than all other

varieties on the Anira peat and also ranked highest on the Inki clay (23.1 t/ha). Further, all five of the introduced varieties ranked between first and seventh on the two soils.

At harvest, the tubers in the Inki clay plot were generally more numerous but thinner than those on the Anira peat plots. This was probably due to inadequate soil potassium in the former soil. The enhanced yields of Uncle Mack (22 t/ha) on the Inki clay suggests that this variety is better suited to this soil.

An NPK program found to be best for cassava on peat soils in West Malaysia (Chew 1970) was adopted for these trials. Yields of five varieties grown under the same climatic conditions and on unfertilized and unlimed plots on the Inki clay averaged 5.3 t/ha fresh roots in 12 months. Hence, the benefits derived from lime and fertilizers are unquestionable and may be further enhanced when optimum quantities of N, P, and K for these particular soils are determined. Neither plant height nor branching pattern appeared to have any relation to yield. Partitioning of total fresh matter diverted into the roots (harvest index) was greater on the Anira peat than on the Inki clay. It is plausible that due to low K in the Inki clay, shoot growth increased at the expense of root fresh matter accumulation. Correlation coefficients ( $r$ ) for fresh yields against harvest index were significant ( $p = 0.05$ ) for both soils and were 0.64 for the Anira peat and 0.85 for the Inki clay. Useful fresh and dry matter yields were also significantly correlated with fresh root yields on both soils ( $r = 1.00, 0.99, 0.96, 0.90$ ).

Chew, W. Y. *Varieties and N,P,K fertilizers for tapioca (Manihot utilissima Pohl) on peat*. Malaysian Agricultural Journal, 47(4), 1970, 483–491.

Mahadeo, C. *Soil survey — New land*. Technical Report. Agriculture Department, Bookers Sugar Estates Ltd., Guyana (mimeographed report), 1975.

Steele, J. G., and Ramdin, H. N. *Soil resources of Guyana*. Ministry of Agriculture, Central Agricultural Station, Mon Repos, Guyana, 1975.

## Cassava Research in Nigeria Before 1972

E. E. Umanah<sup>1</sup>

This review of cassava research achievements in Nigeria over a period of 20 years pays particular attention to plant breeding, agronomy, chemical analysis, physiology, pests and diseases, and cytogenetics. Breeding objectives and varieties recommended for the various ecological areas of the country are discussed.

A package of management practices as recommended from research results is given. On basic research, the karyotypes of some *Manihot* species including cassava were determined, and it was suggested that cassava is an allopolyploid with chromosome number of  $2n = 36$  and a basic chromosome number of  $X = 9$ .

Cassava is of great importance in the national economy of Nigeria, and is second only to yams in total root crop production. However, cassava produces more calories per acre than yams and is easier to cultivate. In addition to its food uses, cassava is also used in industrial processes. By 1985, Nigeria hopes to produce 13.9 million tons annually.

The objective of this paper is to document the research achievements on this crop over a period of 20 years.

### History of Cassava Research

Selected high-yielding disease-resistant varieties of cassava were introduced to Nigeria about 1940. Following trials in the eastern part of the country GCH 7 or 37065 was recommended for cultivation about 1942 because it was higher yielding than local varieties and was tolerant to mosaic disease. About 1953, variety 53101 was recommended to the Western Region and the southern part of the Northern Region.

Although some collections, introductions, and work on mosaic disease had been done as far back as 1932, serious and systematic cassava research for improvement by breeding and cultural practices was only initiated in 1955 when a plant breeder was assigned to the cassava improvement program.

The objectives of this improvement program included: (1) high yield of tubers; (2) high starch content; (3) high dry matter content; (4) high protein content; (5) low hydrocyanide content; (6) good quality; (7) cassava mosaic disease resistance; and (8) improved cultural practices.

To achieve these objectives, cassava collections of varieties grown in different ecological

zones in Nigeria and from foreign countries were initiated, and a selection of the highest yielding types was made. These introductions included *Manihot glaziovii* from Puerto Rico, *Manihot melanobasis* and *M. saxicola* from Surinam, and interspecific hybrids such as 58308, 58198, and 58212 from Amani in East Africa, which were resistant to mosaic disease. Variety 58308 was low in prussic (hydrocyanic) acid, however it was also low in tuber yield.

The country can be divided into two broadly based ecological zones on the basis of consumer preference. In areas north of Minna, consumers prefer "sweet" cassava, which is eaten raw or boiled and made into "tuo." In areas south of Minna down to the coast, the emphasis is on gari production from "bitter" cassava.

Samaru was selected on this basis as the centre for collections and trials for the Northern States. The area south of Minna was divided into four ecological and administrative zones for collections and variety trials.

Hybridizations within the species *M. esculenta* were carried out to obtain high-yielding mosaic tolerant/resistant types with desirable agronomic characters. Crosses involving the varieties 53101 and 42074 as parents and 53101 and 32031 as parents gave consistently high yielding hybrids. Seedlings of these hybrids were raised in nurseries, and subsequent multiplication stages were tested in progeny trials replicated at various centres and finally in zonal centres. No one variety was consistently high yielding at all locations. This led to independent selections of cassava hybrids in the different climatic zones of the country. Combined analysis of the trials showed that varieties 60444, 60506, 60447, and 53101 were the highest yielding selections and were recommended for cultivations in the various ecological zones, Table 1.

<sup>1</sup>Federal Department of Agricultural Research, P.B.M. 5042, Ibadan, Nigeria.

Table 1. Recommended mosaic-disease resistant cassava varieties and their qualities.

Variety	Yield (t/acre)	Mean increase over local variety (%)	Recommended to be planted in (States)	Starch content at 15-18 months (%)	HCN (mg/100 g)
37065 (GCH7)	8.9	28.0	Eastern Nigeria	23.0	182.0
44086 (Congo) (Sweet)	5.6	8.2	Eastern Nigeria	22.0	135.0
53101	13.6	64.5	Western, Kwara, B/Plateau, Southern parts of N/West State	30+	185.0
Dan Wari (Sweet)	8.5	32.0	Cassava growing areas north of 10°N latitude	30	145.0
60444	16.3	95.3	Mid-West, East Central, South-East, Rivers, Lagos	25-30	162.0
60506	15.4	78.0	Western, Kwara, B/Plateau, Southern parts of N/West, Mid-West, East Central, South-Eastern	30	162.0
60447	15.0	55.1	Mid-West, East Central, South-East, Rivers, Lagos	25-30	189.0

Interspecific hybridization of clones, selected as described above, with other species of *Manihot*, such as *M. glaziovii*, *M. saxicola*, and *M. melanobasis*, was designed to introduce characteristics for mosaic disease resistance and high protein content in cassava. Hybrids from crosses made between selected cassava varieties and *M. glaziovii* usually broke down in resistance to mosaic disease within a few generations.

Cassava varieties with high protein content are of importance where tubers are consumed raw by humans or fed to livestock. *M. esculenta* has only about 1.6% crude protein in fresh tubers, but tubers of *M. melanobasis* and *M. saxicola* have crude protein contents of over 10%. This necessitated the production of interspecific hybrids from *M. esculenta* crossed to *M. melanobasis*. Cassava variety 50100 was crossed with *M. melanobasis* (58186). Back crosses were made to *M. melanobasis*, but although the protein contents of the back cross progeny were improved, the total tuber yield was low. Further crosses to the high yielding varieties are to be carried out.

### Chemical Analysis of Tubers

Tuber analyses for starch content, dry matter content, and hydrocyanide content were carried out for all promising varieties to assess the

qualities of these varieties. It was generally found that bitter cassava contained more starch than sweet varieties. The starch content of tubers also varied with age—the highest starch content being found at the age of 15–18 months. Depending on varieties, the range was 20–30% of fresh tubers. The dry matter content of cassava tubers varies with the starch content. The range is between 30 and 40% of fresh tuber weight harvested at 12 months (figures as high as 40–50% are common for tubers harvested at 15–18 months).

The hydrocyanic acid content of tubers is a very variable characteristic, which is subject to environmental influence (Jones 1959). With cyanide titrations it has been found to vary within the tuber and within the variety. Drier soils appear to favour high concentrations of the acid. The relationship between the acid content and taste of the tuber (sweet/bitter) has not been assessed.

### Physiology and Seed Germination

Experiments on effects of different ranges of temperature and scarification on the germination of cassava seeds were carried out. Outcrossed seeds of cassava varieties 60444, 58308, and 53101 were subjected to temperatures from 35 to 50 °C for 24 hours and then soaked in water at ambient temperature for 24

Table 2. Effect of time of planting on yield of different varieties.<sup>a</sup>

Time (months)	Yield of different varieties (lb/plot)				Mean (t/acre)
	53101	60444	60447	60506	
June	775	789	844	716	15.8
July	694	761	678	657	14.1
August	306	484	328	297	7.2
September	257	296	391	325	6.4
October	212	78	209	181	3.4
Mean (t/acre)	9.1	9.8	9.9	8.8	9.4

<sup>a</sup>LSD ( $p = 0.05$ ) = 18.1 lb/plot or 1.5 t/acre.

hours. Germination in the greenhouse occurred between 15 and 25 days and varied with varieties.

Seeds of other varieties were immersed in water and subjected to periods of heat pretreatment (35 °C) in an attempt to speed up germination. All varieties gave 80% germination between 15 and 20 days after 48 hours of this wet heat pretreatment.

This period of maximum germination was the same as that obtained for scarified seed, which usually completed germination within 15–20 days. Because scarification is time consuming, and results in heavy losses, the 35 °C heat pretreatment for 48 hours was recommended for large scale cassava seed germination (Umanah 1970).

## Agronomy Practices

The experiments on agronomic practices included planting dates, planting method, length of cuttings, number of cuttings, spacing and hence plant population, time of harvesting, and fertilizer practices.

### Planting Date

In the southern parts of the country the period between April and July was found to be the best time for planting, whereas June–August was best in the north. At Ibadan it was shown that planting in June significantly outyielded July, August, September, or October planting (Table 2). In wetter areas, such as Umudike, April and May plantings were shown to be as good as June.

### Harvesting Date

Yield data and starch content of tubers at different times of harvesting were studied. Significant differences were demonstrated for

the different times of harvesting (Table 3). Yield at 18 months was highly significantly superior to that at 12 months and those beyond 18 months. But there was no significant difference between harvesting at 18 months and 15 months. The same trend is shown in the starch content of the tubers (Table 4). There were significant differences in varieties  $\times$  harvesting times interactions although between varieties, the differences were not significant. The highest starch content was found in variety 53101 at 18 months and this was not superior to 15 months harvesting time.

### Planting Method

Investigations on planting methods revealed that multiple cuttings were either buried horizontally or were stuck right side up singly per stand. Erect or slanting orientation of single cuttings two-thirds buried was found to give superior yield to horizontal orientation, because in the latter case numerous main stems formed and the resulting overcrowding reduced yield.

### Length of Cuttings

Experiments with cuttings of different lengths showed that the most efficient length was between 9 and 12 in. Cuttings 9 in. long were recommended to economize on planting material (1 in. = 2.54 cm).

### Spacing and Plant Population

Spacing combinations of 2  $\times$  4, 3  $\times$  3, 3  $\times$  4, 4  $\times$  4, and 6  $\times$  4 ft were tried. The spacing adopted varied with variety used. For instance, it was found that varieties that were tall and had a scanty canopy with little branching did well with 3  $\times$  3 ft spacing, whereas those that had little branching and a thick canopy, e.g. 60444, required a spacing of 3  $\times$  4 ft. An

Table 3. Effect of time of harvest on yield of different varieties.<sup>a</sup>

Variety	Time of harvest (months)					Mean (t/acre)
	12	15	18	21	24	
60447	687	987	1061	1001	946	15.8
53101	756	883	1087	994	724	15.3
37065	625	665	871	625	669	11.7
44086	444	680	588	463	452	8.6
Mean (t/acre)	10.6	13.8	14.9	13.2	11.8	12.9

<sup>a</sup>LSD ( $p = 0.05$ ) = 29.5 lb/plot or 1.2 t/acre.

average spacing of  $3 \times 4$  ft (12 ft<sup>2</sup>) of feeding area gave a good average yield for all varieties. The recommended spacing is 3 ft apart on ridges separated by 4 ft, giving a plant population of 3630 stands/acre for a sole cassava crop (1 acre = 0.4 ha).

### Fertilizers

Initially, great controversy existed about the application of fertilizers to cassava, due probably to the low yield returns from the unimproved varieties, which were cultivated. However, with the recommendations for improved varieties, fertilizer practices were also recommended. Experiments, which were carried out mainly in the Eastern Region between 1960 and 1967, revealed that the new cassava varieties were responsive to fertilization (Phillips 1973). It was therefore recommended that on acid soils (pH < 5.0) lime should be applied at a rate of 1500 lb/acre before planting. Then nitrogen as sulfate of ammonia and phosphorus as single superphosphate should be applied together with sulfate of potash as a 10:10:20 mixture at the rate of 240–300 lb/acre for a sole cassava crop. Nitrogen and potash are more important for cassava than phosphorus. Time of application was given as 3 months after planting provided there was enough moisture available. When cassava is repeatedly grown as a sole crop on the same land, such as in a plantation, or in a rotation system, fertilizer must be applied to obtain a good crop.

### Pests

Several pests of the cassava plant exist, but most of them are not serious and some are seasonal.

*Bemisia nigeriensis (tabaci)* or the white fly is the vector of the cassava mosaic disease. Golding (1936) showed that this insect trans-

mitted the virus from one cassava plant to another. The grasshopper, *Zonocerus variegatus*, causes seasonal damage to the leaves of cassava during the dry season. They move in swarms and devour the plants. They can be controlled by spraying with gammalin 20. The cricket, *Gryllotalpa africana*, causes damage to young seedlings in the nursery. These crickets can be controlled by digging and killing since they are active mostly at nights and hide in holes during the day. Termites can destroy a whole plot of newly planted cassava cuttings, especially if the weather is also dry. Sometimes they also attack mature cassava plants. They can be controlled by dusting the planting materials with 2.5% aldrin dust. Red spider mites are more common during the dry season. They are very small and cannot be easily seen with the naked eye. They feed on leaf blades and cause symptoms that can be mistaken for cassava mosaic disease. However, they can be controlled by spraying with gammalin 20. Rodents, bush fowl, and even goats can be menaces to a cassava plot. Both rodents and bush fowls dig up and eat the cassava roots, whereas goats eat the leaves and break the stems.

### Diseases

Cassava mosaic disease manifests itself in different degrees depending on the cassava variety. In general, a high degree of mottling, curling of leaves, distortion, and in some cases reduction in size of leaves and stunting of plants occur. The vector of the disease is *Bemisia nigeriensis (tabaci)* or white fly. Golding (1936) showed that this disease caused up to a 30% reduction in yield. In East Africa, Tidbury (1937) demonstrated a reduction of up to 95% in yield. In Ibadan, Beck and Chant (1958) showed for variety 56160 that primary infection caused a reduction of 29% in yield. The only solution appeared to be resistant

Table 4. Effect of time of harvest on percentage starch yield.<sup>a</sup>

Time of harvest (months)	Variety				Mean
	53101	44086	60447	37065	
18	26.6	22.0	23.2	18.7	21.9
15	24.2	21.3	18.2	18.8	20.2
12	19.4	17.8	16.0	15.5	17.9
24	19.6	16.2	15.1	17.5	17.1
21	15.0	19.0	16.1	12.2	16.0
Mean	21.0	19.3	17.7	16.5	18.6

<sup>a</sup>LSD ( $p = 0.05$ ) = 5.2 (variety).

varieties. Treatment of the cuttings by heating at temperature of 37–39 °C inactivates the virus and prevents primary field infection, however this does not prevent the secondary infection.

Brown leaf spot, caused by *Cercospora henningsii*, results in mature leaves becoming senescent faster than unaffected leaves. The effect of this disease on yield has not been assessed. White leaf spots, caused by *Cercospora caribaeae*, occurs along with brown leaf spot, but the lesions are smaller than the brown leaf spots.

Die bäck is caused by *Glomerella cingulata* in some plants. The disease is not wide-spread.

Yellow rot is caused by the fungus *Polyporus bandoni*, and is common in damp or water-logged soils. The infected lower stem and roots are covered with orange-yellow mycelium and orange coloured sporophores are produced.

Bacteria wilt, first reported in 1972 by Williams et al. (1973), causes wilting of leaves and stems. The disease is very serious and requires intensified effort to eradicate it.

**Basic Cassava Research**

Cytogenetic studies of cassava *M. esculenta* and *M. glaziovii* were carried out (Umanah and Hartmann 1973). The chromosome numbers of these two species were found to be  $2n = 36$ . The karyotypes of the two species were similar. Two pair of satellite chromosomes were reported for the first time for both species.

Meiosis was normal in pollen mother cells; the 18 bivalents at M1 disjoined regularly at A1. It is suggested that these *Manihot* species are allopolyploids with a basic chromosome number of  $X = 9$ . This conclusion confirms that of Perry (1943).

Beck, B. D. A., and Chant, S. R. *A preliminary investigation on the effect of cassava mosaic virus on M. utilisissima Pohl in Nigeria*. Trop. Agric. Trin. 35(1), 1958, 59–64.

Golding, F. D. *Bemisia nigeriensis Corb; a vector of cassava mosaic in Southern Nigeria*. Trop. Agric. Trin. 13(7), 1936, 182–186.

Golding, F. D. *Cassava mosaic in southern Nigeria*. Nigeria Dept. of Agric. Ann. Bull. 11(1), 1936.

Jones, W. O. *Maniocin Africa*. Stanford University Press, Stanford, USA, 1959.

Perry, A. B. *Chromosome number and phylogenetic relationships in the Euphorbiaceae*. Amer. J. Bot. 30, 1943, 527–543.

Phillips, T. A. *An agricultural notebook*. Longmans of Nigeria, Ikeja, Nigeria, 1973.

Tidbury, G. E. *Effect of cassava mosaic disease on yield of cassava*. E. African Agric. J. 3, 1937, 119.

Umanah, E. E. *The germination of cassava seeds: The effect of temperature and scarification*. Proc. Agric. Soc. Nigeria, 7, 1970, 54.

Umanah, E. E., and Hartmann, R. W. *Chromosome numbers and karyo types of some Manihot species*. J. Amer. Soc. Hort. Sci. 98(3), 1973, 272–274.

Williams, R. J., Agboola, S. D., and Schneider, R. W. *Bacterial wilt of cassava in Nigeria*. Plant Dis. Rep. 57(10), 1973, 824–827.

## Production of Cassava Foliage

A. Montaldo and J. J. Montilla<sup>1</sup>

Investigations were carried out on the production of foliage from cassava for use as protein in animal feed. The best results were obtained with successive cuttings of foliage at intervals of 3–4 months with plant densities of 31 250 and 15 625 plants/ha. The production rates obtained were: 14.5 t/ha of dry foliage in 12 months during the dry season, 19.6 t/ha in 12 months during the rainy season, and 35.2 t/ha in 17 months during the rainy season. The protein content of the material (stems, branches, and leaves) varied between 13.8 and 22.3% with a maximum protein yield of 2.7 t/ha per year.

The blades of the cassava leaf have a protein content of about 25%. This makes the crop a rich and cheap source of protein, which may be substituted for alfalfa foliage meal and other protein sources that are difficult and costly to obtain. Plant densities, crop management, and protein content of the total foliar mass were studied because little published information is available on these subjects.

### Methods and Materials

Cassava variety Cacho de Toro Amarga (UCV-2078) was planted in a split plot design with three replications at Maracay, Venezuela. No chemical fertilizer, manure, or lime was applied to the soil.

Plant densities were changed by varying the spacing within the rows, which were 80 cm apart. The densities were: (1) 31 250 plants/ha (40 cm between plants); (2) 15 625 plants/ha (80 cm between plants); and (3) 10 412 plants/ha (120 cm between plants).

Three different harvesting frequencies were used in the dry season: (1) foliage (leaves, branches, and stems) at 4, 8, and 12 months (3 harvests) and roots at 12 months; (2) foliage at 8 and 12 months (2 harvests) and roots at 12 months; and (3) foliage at 12 months (1 harvest) and roots at 12 months. Three harvest schedules were also used during the rainy season: (1) foliage at 3, 6, 9, 12, 14, and 17 months; (2) foliage at 6, 9, 12, 14, and 17 months; and (3) foliage at 9, 12, 14, and 17 months.

Foliage was harvested by cutting the plants at ground level with a machete. The total foliage production per plot was weighed in the field (2 central rows), and this material was later ground in a hammer mill. After the

material was carefully ground and mixed, a 500 g sample was extracted for each sub-treatment in each of the replications. The material was dried in an oven at 80 °C for 48 h to determine the total dry matter of the foliage.

Total weight, weight per plant, average root weight, total number of roots, total dry matter percentage, and weight per hectare were noted in the root harvest of the dry season trials.

### Results

#### Dry Season Production (12 Month Cycle)

Harvest frequency had a significant effect on fresh foliage production. Frequency 1 (average yield 58.9 t/ha) and frequency 2 (average yield 55.0 t/ha) harvests were significantly different from the frequency 3 yield (39.4 t/ha). The highest yields of fresh foliage (64.6 and 63.6 t/ha) corresponded to a density of 31 250 plants/ha, with harvests at 4, 8, and 12 months, and at 8 and 12 months, respectively.

Harvest frequency also had a significant effect on the production of dry foliage. The average yield for frequency 1 was 13.7 t/ha, which was significantly different from the frequency 3 harvest of 9.7 t/ha. The yield of frequency 2 (12.0 t/ha) was not significantly different from frequency 1. The highest dry foliage yield was 14.5 t/ha, corresponding to frequency 1 at 31 250 plants/ha.

Plant density did not exert a significant effect on the production of fresh roots. The largest production (18.0 t/ha) was in frequency 3 (harvest at 12 months). This was significantly different from frequency 1 yield (8.7 t/ha). Since no significant differences were observed between frequency 2 and 3 yields, the cutting of foliage at 8 months did not significantly influence the yield of fresh roots. The highest individual yields (21.8 t/ha) were obtained at density 2 (15 625 plants/ha) with foliage harvest at 12 months.

<sup>1</sup>Faculties of Agronomy and Veterinary Medicine, respectively, Universidad Central, Maracay, Venezuela.

Harvest frequency exerted a significant effect on the production of dry roots. The yield of frequency 3 (foliage and root harvest at 12 months) was the highest (5.7 t/ha), and was significantly different from frequency 1 yield (3.1 t/ha). No difference was observed between frequency 2 and 3 yields, indicating that cutting the foliage at 8 months does not affect the dry matter production of cassava roots.

### Rainy Season Harvest (12 Month Cycle)

Fresh foliage production was 86.4, 68.4, and 59.1 t/ha for densities 1, 2, and 3, respectively. Density 1 showed a highly significant difference from density 3, and a significant difference from density 2.

Density 1 dry foliage production was highly significantly greater than densities 2 and 3. There were no statistical differences between densities 2 and 3. Frequency 3 had the highest yield (foliage harvest at 9 and 12 months) (17.7 t/ha). This was significantly greater than frequency 1 (3, 6, 9, and 12 months) (14.5 t/ha).

In fresh foliage production, density 1 (31 250 plants/ha) yielded significantly more than density 2 (15 525 plants/ha) and density 3 (10 412 plants/ha). The highest yields of fresh foliage were 154.9, 165.7, and 147.7 t/ha for frequencies 1, 2, and 3 at density 1.

Density 1 (31.9 t/ha of dry foliage) yielded significantly more than densities 2 (24.2 t/ha) and 3 (22.0 t/ha).

The protein contents of the cassava foliage determined from the first harvest of the dry season were superior to those of the third

harvest, because there was a greater proportion of herbaceous material (leaves and sprigs) at 4 months than at 12 months. The protein production values of cassava foliage were highest for density 1 and for frequency 1, with values of 2.2 and 2.4 t/ha of protein, respectively.

### Conclusions

By comparing the foliage production of dry and rainy season planting over a 12 month period, it is evident that for both fresh and dry matter production, planting the crop in the rainy season is better.

During the dry season, cutting frequency but not plant density exerted a significant effect on fresh foliage production. In the wet season, both density and cutting frequency influenced foliage yield.

Root production was seriously affected by cutting the foliage at 4 months. However, cutting at 8 months only reduced yield slightly because the roots had already formed and accumulated reserve material.

Excellent dry foliage and protein production can be obtained by successive cuttings at 3, 6, 9, 12, 14, and 17 months.

It would seem advantageous for foliage production in the ecological conditions found in Maracay to plant in the rainy season, with densities of between 31 250 and 15 625 plants/ha. Harvests should then be done every 75–90 days, up to 17–20 months. Production should be for foliage only, not roots and foliage. It will be necessary to develop a system to mechanically prune the foliage and thus reduce the manual labour factor.

---

## The Effect of Various Levels of Cassava Leaf Meal in Broiler Chicken Rations

J. J. Montilla, R. Vargas, and A. Montaldo<sup>1</sup>

Cassava leaf meal was used as a protein source in the rations of 1-day-old Vantress × White Rock chicks. When rations were administered in meal form, body weight gain and dietary efficiency were depressed at all levels of foliage addition up to the sixth week. This depression was noticeable during the last 4 weeks only at the top level of substitution. Pelleting greatly improved the adverse effects that appeared when the feed was given in meal form.

---

<sup>1</sup>Faculties of Veterinary Science and Agronomy, Universidad Central, Maracay, Venezuela.

Harvest frequency exerted a significant effect on the production of dry roots. The yield of frequency 3 (foliage and root harvest at 12 months) was the highest (5.7 t/ha), and was significantly different from frequency 1 yield (3.1 t/ha). No difference was observed between frequency 2 and 3 yields, indicating that cutting the foliage at 8 months does not affect the dry matter production of cassava roots.

### Rainy Season Harvest (12 Month Cycle)

Fresh foliage production was 86.4, 68.4, and 59.1 t/ha for densities 1, 2, and 3, respectively. Density 1 showed a highly significant difference from density 3, and a significant difference from density 2.

Density 1 dry foliage production was highly significantly greater than densities 2 and 3. There were no statistical differences between densities 2 and 3. Frequency 3 had the highest yield (foliage harvest at 9 and 12 months) (17.7 t/ha). This was significantly greater than frequency 1 (3, 6, 9, and 12 months) (14.5 t/ha).

In fresh foliage production, density 1 (31 250 plants/ha) yielded significantly more than density 2 (15 525 plants/ha) and density 3 (10 412 plants/ha). The highest yields of fresh foliage were 154.9, 165.7, and 147.7 t/ha for frequencies 1, 2, and 3 at density 1.

Density 1 (31.9 t/ha of dry foliage) yielded significantly more than densities 2 (24.2 t/ha) and 3 (22.0 t/ha).

The protein contents of the cassava foliage determined from the first harvest of the dry season were superior to those of the third

harvest, because there was a greater proportion of herbaceous material (leaves and sprigs) at 4 months than at 12 months. The protein production values of cassava foliage were highest for density 1 and for frequency 1, with values of 2.2 and 2.4 t/ha of protein, respectively.

### Conclusions

By comparing the foliage production of dry and rainy season planting over a 12 month period, it is evident that for both fresh and dry matter production, planting the crop in the rainy season is better.

During the dry season, cutting frequency but not plant density exerted a significant effect on fresh foliage production. In the wet season, both density and cutting frequency influenced foliage yield.

Root production was seriously affected by cutting the foliage at 4 months. However, cutting at 8 months only reduced yield slightly because the roots had already formed and accumulated reserve material.

Excellent dry foliage and protein production can be obtained by successive cuttings at 3, 6, 9, 12, 14, and 17 months.

It would seem advantageous for foliage production in the ecological conditions found in Maracay to plant in the rainy season, with densities of between 31 250 and 15 625 plants/ha. Harvests should then be done every 75–90 days, up to 17–20 months. Production should be for foliage only, not roots and foliage. It will be necessary to develop a system to mechanically prune the foliage and thus reduce the manual labour factor.

---

## The Effect of Various Levels of Cassava Leaf Meal in Broiler Chicken Rations

J. J. Montilla, R. Vargas, and A. Montaldo<sup>1</sup>

Cassava leaf meal was used as a protein source in the rations of 1-day-old Vantress × White Rock chicks. When rations were administered in meal form, body weight gain and dietary efficiency were depressed at all levels of foliage addition up to the sixth week. This depression was noticeable during the last 4 weeks only at the top level of substitution. Pelleting greatly improved the adverse effects that appeared when the feed was given in meal form.

---

<sup>1</sup>Faculties of Veterinary Science and Agronomy, Universidad Central, Maracay, Venezuela.

Table 1. Body weight and dietary efficiency gains in experiment 1.

Treatment	0-6 weeks		0-8 weeks		0-10 weeks	
	BW	DE	BW	DE	BW	DE
0%	1049Aa	2.3Aa	1495Aa	2.6	1920As	2.8Aa
10%	940Bb	2.6Bb	1395Ba	2.8	1845Aab	3.0Aab
20%	801Cc	2.8Cb	1262Cb	3.0	1699Bbc	3.1Bb

NOTE: Different lower case letters after values in a column indicate significant differences ( $p = 0.01$ ); different capital letters after values in a column indicate significant differences ( $p = 0.05$ ).

Cassava foliage has a high protein content that may be as high as 22% when it is cut at 2-month intervals. When cassava is planted for the sole purpose of harvesting its leaves, yields of up to 150 t/ha per year may be obtained. Therefore, cassava should be considered as an alternative when trying to solve the problem of protein deficiency in rations for domestic animals in the tropics.

According to Eggum (1970), the protein in cassava leaf matter is deficient only in methionine and its biological value, as determined in rats, reaches from 49 to 80% when supplemented with this amino acid. At the same time, nitrogen is increased from 2.04 to 3.02%.

Ross and Enriquez (1969) fed poultry with rations containing meal from the leaves and stalks of cassava at levels of 3-20%. They found depression in growth and dietary efficiency. This situation was remedied by supplementing with 0.2% methionine and 3% corn oil. They concluded that methionine was the first limiting factor, and that energy was the second, in chicken rations containing cassava leaf meal.

The objective of this study was to further investigate the possibility of using cassava leaf meal in broiler rations.

## Material and Methods

Two 10-week tests were carried out, in a completely randomized system, using a total of 480 Vantress  $\times$  White Rock 1-day-old chicks. The test unit in both experiments was 10 broilers, with four groups assigned to each treatment. The birds were placed in four-tiered, metal batteries that were electrically heated. A daily record of feed consumption was kept, and the chicks were vaccinated against fowl pox, avian diphtheria, and Newcastle disease. The rations administered were prepared starting

from a base ration of corn, sesame, cotton, soybean, meat, and bone and fish meal, balanced for all nutrients.

The cassava leaves contained: 93.5% dry matter; 21.4% crude protein; 4.8% ether extract; 27.1% crude fibre; 36.9% nitrogen-free extract; and 9.9% ash. The meal was prepared by chipping the foliage in a stationary chipper, drying it in the sun for about 24 h, and then grinding it in a hammer mill.

The cassava leaf meal was added to the basic ration at levels of 10, 20, and 30%, substituting the oil-seed (sesame and cotton) and the cornflour by 75 and 25%, respectively, for each substitution level. The rations with cassava leaf meal were supplemented with 0.15% methionine for every 10% of foliage added.

In the first experiment, feed was administered in the form of meal and, in the second, rations in the form of meal and pellets were compared. Water and feed were administered freely and a daily record of consumption kept. The broilers were weighed at the start of the experiments and then every 2 weeks. The data were subjected to variance analysis and to Duncan's multiple comparison tests.

## Results and Discussions

Table 1 summarizes the data for experiment 1 for body weight gain and dietary efficiency. There was a highly significant linear depression ( $p = 0.01$ ) for body weight gain at the second week. This situation continued up to the sixth week, when the broilers fed on the rations with 20 and 30% cassava leaf meal reached only 83.5% of the gain reached on the basic ration. Body weight gains reached during the seventh, eighth, ninth, and tenth weeks were very similar for all treatments, indicating that the broilers made better use of the rations with the cassava leaf meal as they grew older.

Table 2. Body weight and dietary efficiency gains in experiment 2.

Treatment	0-6 weeks		0-8 weeks		0-10 weeks	
	BW	DE	BW	DE	BW	DE
F-0%	1110a	2.1a	1469bc	2.1a	1987c	2.5a
F-0%-P	1093a	2.2abc	1615a	2.5bc	2123a	2.8bc
F-10%	1002ab	2.3abc	1463c	2.6cd	1962c	2.8c
F-10%-P	1026ab	2.4abc	1612a	2.5bc	2089b	2.7bc
F-20%	886cd	2.6c	1311e	2.9ef	1774e	3.2def
F-20%-P	995ab	2.5abc	1511b	2.8de	1972c	3.1cde
F-30%	759c	3.2d	1190f	3.3g	1720f	3.4f
F-30%-P	932bd	2.6bc	1387d	3.0f	1870d	3.3f

NOTE: F = foliage; 0, 10, 20, and 30% = levels of addition; P = pelleted. Different lower case letters after values in a column indicate significant differences ( $p = 0.01$ ).

A similar situation existed with regard to dietary efficiency. This was depressed at each level of foliage addition up to the sixth week. At the eighth week, noticeable differences existed only between the ration with 30% foliage and the other three. The fact that the relatively large differences that are shown in dietary efficiency during the second and tenth weeks do not show significance, is due to the large losses caused by food spillage that results in a high degree of individual differences among groups. This food spillage was due to the low consistency given to the meal by the foliage.

It is evident that at any of the levels of cassava leaf meal studied, with meal type rations, at least 9 weeks are required for broilers to reach marketable body weight. At the tenth week, the efficiency of food conversion was reduced by 5.7, 12.1, and 23.2% when foliage was added at levels of 10, 20, and 30%.

Table 2 summarizes the information obtained from experiment 2. It is evident that the meal preparation in pellet form improved body weight gains and dietary efficiency, up to the eighth week. This effect was not shown for the ninth and tenth weeks, during which time, no appreciable differences were noted, either for the form of the feed or between the levels of cassava foliage used.

The best body weight and food conversion gains were reached with the basic ration, but

the differences shown between this and the pelleted rations, with 10 and 20% foliage, although significant in some cases, were small and comparable to those recorded in commercial enterprises.

On the other hand, the reduction in ration costs largely compensates for the reduction in dietary efficiency. With the ration of 30% foliage in pellet form, weight gain was comparable with commercial levels, but the dietary efficiency loss was large. The economic effect must be evaluated before deciding whether to use foliage at this level. This would necessitate obtaining cassava foliage production cost data.

## Conclusions

This preliminary work suggests that it is possible to add cassava leaf meal, at relatively high levels, to the rations of broiler chickens in pellet form. Studies should continue in an attempt to clarify the possibility of using this material.

- Eggum, B. O. *The protein quality of cassava leaves*. British J. Nutrition, 24, 1970, 761-768.
- Montilla, J. J., Garcia, I. A., and Reveron, A. E. *Valor pigmentante de diversas harinas verdes agrupadas a las raciones para pollos de engorde y su efecto sobre el incremento de peso*. Ciencias Veterinarias, 2, 1973, 258-290.
- Ross, E., and Enriquez, F. Q. *The nutritive value of cassava leaf meal*. Poultry Sci. 1969, 846-853.

## Sweet Potato Production, Handling, Curing, Storage, and Marketing in North Carolina

L. G. Wilson, C. W. Averre, and H. M. Covington<sup>1</sup>

North Carolina has an excellent climate and soil for producing high yields of quality "yam-type" sweet potato cultivars. 'Jewel,' which stores well for over 9 months, originated from this state. Over the past 30 years, the combined efforts of research and extension scientists and interested growers and persons in agribusiness industries have minimized the effects of diseases and insects, and introduced improved production, harvesting, curing, storage, and marketing techniques. North Carolina is the leading sweet potato producing state in the United States and produces over one-third of the crop. Growers and shippers have a well-organized, effective association to promote their products nation-wide and to support all aspects of the sweet potato industry. Sweet potatoes are the leading horticultural commodity in North Carolina and are sold in every marketing area east of the Rocky Mountains. Discussion includes problems, current investigations, and future trends.

The sweet potato (*Ipomoea batatas*) is grown commercially as an annual crop in the United States, even though it grows as a perennial in the Neotropics, its centre of origin. This crop has been grown in North Carolina for nearly two centuries and has been the leading horticultural crop in this state for much of this century. North Carolina has led all states in sweet potato production since 1969, due in no small part to its ability to produce efficiently and thereby compete effectively in many markets.

The success of the North Carolina sweet potato industry is partly attributable to the many contributions of a group of research and extension scientists at North Carolina State University, the members of support industries in the agribusiness community, plus growers who are interested in developing better ways to grow sweet potatoes. An important factor responsible for North Carolina's success has been the keen interest of growers and shippers and their formation of the North Carolina Yam Commission, Inc. in 1961. This well-organized, cohesive group of growers and shippers has successfully promoted research and development, and the production and marketing of quality sweet potatoes. Their voluntary assessment on this product (2¢ per bushel fresh, 2¢ per cwt processed) has provided funds to gain market territories through merchandising, promotion, and advertising efforts. They have imposed seasonal limitations on themselves on the sale of freshly harvested, uncured sweet potatoes. They continue to strive for an improved

consumer quality image and greater operational efficiency with the capability of relating to the needs of world markets in the future.

Another aspect of the success story in North Carolina is related to the peculiar prominence of tobacco, its allotment system, and the consolidation of tobacco allotments. The number of farms in North Carolina is second only to the State of Texas. Many of these farmers are constantly seeking new crops to grow, since tobacco production is essentially a "closed shop" and ever larger farming units are necessary. Sweet potatoes and tobacco are somewhat complementary crops with regard to labour utilization and field operations.

### Cultivars

'Porto Rico,' and more recently 'Centennial,' were the predominant cultivars in North Carolina until the early 1970s. In 1969, 'Jewel' was released by the North Carolina State University Agricultural Experiment Station. Although poorly received by the industry at first, North Carolina growers and shippers soon realized that 'Jewel' was a high yielding (ca. 500 bushels/acre avg, up to 1000 bushels/acre experimentally), high quality, fresh market sweet potato with excellent storage, and good processing qualities. They found it to be widely adaptable, early sizing ("chunky" shape), soft-fleshed, and resistant to several diseases (i.e. *Fusarium* wilt, internal cork virus, and southern root-knot nematode) and some insects (i.e. flea beetle). Its popularity has increased annually, and in 1976 over 75% of the acreage of sweet potatoes in North Carolina were planted to 'Jewel.' This cultivar is also popular in many

<sup>1</sup>Agricultural Extension Services, North Carolina State University, Raleigh, N.C. 27607, USA.

other sweet potato producing areas of the United States.

Major weaknesses of 'Jewel' include its susceptibility to "souring" in wet soils (anaerobic soil conditions) and skinning. For these reasons, some growers still plant some 'Centennial' and other "wet tolerant" cultivars. These problems maintain high priorities in the current sweet potato breeding program in North Carolina.

### Transplant Production

The "seed program" of each grower is critical and much thought and effort is expended on this phase of each successful operation. The North Carolina Crop Improvement Association, primarily through the North Carolina Certified Sweet Potato Growers' Association, cooperates with North Carolina State University and the sweet potato industry. This organization is responsible for certifying each sweet potato cultivar as to purity and freedom from certain pests and diseases. Crop improvement personnel perform field and storage inspections and work closely with the sweet potato breeding program at North Carolina State University. Growers are urged to purchase 5–10% of their requirements each year as either certified seedstock or certified transplants so that their planting stock is never more than two generations removed from certified stock.

Presprouting seedstock at curing temperatures (ca. 30 °C) for approximately 4 weeks prior to bedding results in more prolific sprout production (Covington 1962) and has become a standard practice in North Carolina. Unfortunately, some growers do not fully comprehend that metabolic activity of the seedlings increases during presprouting, presenting a greater demand for oxygen and producing more carbon dioxide. Insufficient ventilation results in poor sprout production and often causes seed stock to rot before bedding.

Sweet potato seed stocks are placed in beds elevated about 10 inches (25 cm) and are most commonly about 3 ft (1 m or less) in width, depending on the grower's operation. Due to the high cost of labour, careful hand placement of the roots has generally been replaced by pouring seed roots from boxes or pallet bins. Most seed roots are dipped in, or drenched with, a fungicide and the beds are treated with a herbicide. A uniform covering of 2 inches of soil and 2-mm clear plastic covers are recom-

mended. Fertilization and irrigation promote more prolific sprouting.

Transplants are generally pulled, but where scurf or black rot are suspected, growers are careful to cut sprouts off above the ground to avoid transmitting these fungi to their fields. Rotting of roots in the plant beds and/or inferior sprout production is a problem, and deserves attention.

Considerable effort continues to be applied to develop effective systems for direct planting of seed pieces in the field in hopes of reducing the labour requirement for transplant production, which represents approximately one-half of the total cost of sweet potato production in North Carolina. Breakthroughs in seed piece planting do not appear possible with all cultivars due to genetic characteristics.

### Field Preparation

There are approximately 2 million acres (910 000 ha) of soil in eastern North Carolina that are well suited for the production of quality sweet potatoes. Much of this is Norfolk fine sandy loam soil (typically containing 65% sand, 20% silt and 15% clay, with about 1% organic matter), which has good internal drainage and permits good root development. Fertilizers and soil moisture are retained within the sweet potato root zone because these soils are underlaid, 18–20 inches below the surface, with heavier soils containing a much higher percentage of clay. Field selections are generally made in the fall and the soil pH adjusted to 5.8–6.2. The benefits of greater fertilizer efficiency warrant liming, even if the field is rented for only a single season.

After the soil is broken in early spring, it is ridged to promote optimum drainage. This is especially important during the later stages of growth and development when the storage roots are most susceptible to "souring." About 2 weeks prior to transplanting, a preplant fertilizer is incorporated into this ridge along with an appropriate nematicide. Several nematicides are approved and recommended (dichloropropene, EDB (Dowfume, Soilbrom), ethoprop (Mocap), and fensulfothion (Dasanit) (North Carolina State University 1976).

Weed control is accomplished by cultivating plus the use of recommended and approved herbicides (diphenamid (Dymid or Enide), DCPA (Dacthal), chloramben (Amiben) and vernolate (Vernam)). Vernolate must be in-

corporated prior to planting, but the others can be band- or solid-sprayed over the transplanted rows.

Crabgrass (*Digitaria sanguinalis*), ragweed (*Ambrosia artemisiifolia*), lambsquarter (*Cheopodium album*), and cocklebur (*Xanthium americanum*) are the major weed pests in North Carolina sweet potato fields.

Fertilization of sweet potato fields depends on the results of soil analyses, rainfall, and the individual grower's operations. Generally, it is recommended that 90–110 lb/acre (108–132 kg/ha) of nitrogen be applied; about 30 lb (36 kg/ha) at preplant, 40 lb (48 kg/ha) sidedressed at the last cultivation, and another 20 lb (24 kg/ha) broadcast 4–5 weeks later. An additional 20 lb/acre (24 kg/ha) of nitrogen may be used any time following rainfall, which may cause excessive leaching. Phosphorus ( $P_2O_5$ ) is required at about 60 lb/acre (72 kg/ha) and should all be preplant applied. Potassium ( $K_2O$ ) is required at about 150 lb/acre (180 kg/ha), 30 lb (36 kg) of which is preplant applied and the remainder sidedressed at the last cultivation. Many growers have developed their own fertilizer programs. However, a typical schedule may resemble the following: 500–600 lb/acre (560–672 kg/ha) of 6-12-6 banded in the row or broadcast as a preplant application, about 500 lb/acre (560 kg/ha) of 8-0-24 sidedressed at the last cultivation (mid-July) and 100–200 lb/acre (112–224 kg/ha) of sodium nitrate applied as a topdressing 4–5 weeks after the last cultivation (mid-August) and/or as required due to excessive leaching. Since the physiological storage disorder, "blister" affects some varieties grown in North Carolina (i.e. 'Jewel'), 0.5 lb/acre (0.6 kg/ha) of boron is also applied; usually it is formulated in the preplant fertilizer as Borax or Solubor if requested by the grower.

### Diseases

Historically, sweet potato diseases have been a major problem confronting the industry in North Carolina, but they are under reasonable control at this time. Internal cork (a virus disease) and blue stem (*Fusarium oxysporum* f. sp. *batatas*) were extremely serious when 'Porto Rico' and other cultivars were widely grown; 'Centennial' and 'Jewel' possess acceptable levels of resistance. Black rot (*Ceratocystis fimbriata*) and scurf (*Monilochaetes infuscans*) have been under control for approxi-

mately 15 years with a carefully followed plan of crop rotation, sanitation, and use of certified seed. Pox (*Streptomyces impomoeae*) is not present in the major sweet potato growing areas of North Carolina. Southern blight or circle spot (*Sclerotium rolfsii*) occasionally causes locally serious problems. The fungus is soil-borne and is widespread.

The root-knot nematode (principally *Meloidogyne incognita*) is widespread in the sweet potato growing areas of North Carolina. Some growers continue to sustain losses due to nematodes even though excellent control procedures, based on soil sampling and the use of nematicides, have been proven effective. Losses are compounded because yields are reduced and quality is lowered.

Rots of mature and/or harvested storage roots probably cause losses of over 15% annually. These rots are caused by several fungi and possibly some bacteria and viruses. In most cases, however, the indirect or predisposing factors include: soils waterlogged for more than 1 day, bruises, chilling below 10 °C, heating and drying in the sun, and poor curing conditions. These rots continue to be a problem and control is based on proper field selection and handling of harvested roots.

### Insects

At the present time, insects do not cause problems of major proportions in sweet potato production in North Carolina. Numerous insects feed on the foliage but there is no evidence that they cause yield reductions.

Wireworms (*Condoerus falli*, *Condoerus vespertinus*, and *Melanotus communis* in order of importance, respectively) can cause damage by making small holes in the storage roots. These insects are controlled by broadcasting a granular insecticide (i.e. fonophos or Diazinon) over the foliage when the storage roots begin to form.

Various species of white grubs occasionally damage sweet potatoes. Such damage can be minimized by avoiding soils that are high in organic matter and/or by broadcasting and incorporating a granular insecticide into the soil prior to planting.

Flea beetles (*Chaetocnena confinis*) attack sweet potatoes causing damage resembling "writing" on the surface of the storage roots. This insect is best controlled by planting resistant varieties, such as 'Jewel.' Fortunately,

no sweet potato weevil (*Cylas formicilarius elegantulus*) infestations presently exist in North Carolina. To prevent this most destructive insect from getting established, growers are careful to use only seed stock and plants from noninfested areas. If it is necessary to import plants or seed stock from other states they must be certified "weevil-free" by the official certifying agency in the state of origin.

Occasionally, lepidopterous larva (i.e. *Heliothis zea*) on the foliage at harvest may damage exposed, harvested roots by feeding on them.

### Harvesting and Handling

Most sweet potatoes in North Carolina are turned out of the ground by plow and hand-graded into field boxes or 20-bushel pallet bins. This labour-intensive method requires constant, close supervision to ensure that all of the sweet potatoes are "scratched out" of the ground and that they are graded accurately, and to minimize handling damage.

Riding harvesting aids are popular because they keep labourers together and take some of the drudgery out of their work, although they do little to reduce the total labour requirement. The roots are dug and elevated to a horizontal conveyor where they are separated from their vines and graded by hand into appropriate containers. New devining equipment has been developed that virtually eliminates hand vine separation.

A mechanical harvester is available that harvests sweet potatoes and transfers them field-run into 20 bushel pallet bins. This equipment is best suited for freshly harvested green sales, but with careful handling with appropriate hydrohandling equipment, sweet potatoes harvested in this manner can be cured and stored for packaging and marketing at a later date. Avoiding mechanical injuries, prompt placement of roots under curing conditions, and sanitation (in such a system) are essential to minimize storage rots. When properly operated, the paddlewheel transfer system, recently developed in North Carolina, is well suited to such a hydrohandling system.

Experiments with bulk harvesting systems that will handle 100–200 bushel units from the field to storage are currently in progress. This "systems approach" to mechanization could revolutionize sweet potato production and handling.

Approximately 30% of the annual North Carolina sweet potato crop is processed. This represents that portion of the crop that does not meet quality specifications for the fresh market; none are grown specifically for processing. Processed sweet potatoes are generally handled in bulk.

### Curing and Storage

Those sweet potatoes not sold directly from the field at harvest time are cured for 7–10 days at 29 °C at a relative humidity of 90% or higher. Much of the more than 6 million bushels of storage facilities in the state include modern curing facilities. These consist of floor trenches to provide heat and high humidity, fans for the necessary aeration (ventilation), and adequate insulation.

The curing process is primarily one of wound healing (periderm formation) to minimize the invasion of rotting organisms. Curing also promotes the culinary quality of this commodity by inducing the increase of enzymes (primarily  $\alpha$ -amylase), which promotes the hydrolysis of starches to sugars (Walters et al. 1975). The sooner sweet potatoes are cured after harvest the better their quality will be maintained during storage. Delays (between harvest and curing) result in excessive shrinkage in storage and losses due to rots. After proper curing, sweet potatoes are held at 13–15 °C and high humidity with occasional ventilation, until marketed.

### Packaging and Marketing

Nearly all of North Carolina's fresh sweet potatoes are packaged in one bushel fibreboard boxes weighing 50 lb (22.7 kg). Wirebound boxes and bushel baskets, which were used extensively in the past, are now used only for local marketing. Most of North Carolina's sweet potatoes are marketed in eastern and central U.S. population centres. Occasionally, however, they are marketed over the entire country. The crop is marketed fresh all year, but primarily in September through January, with peak marketing periods coinciding with U.S. holidays such as Thanksgiving, Christmas, and Easter.

There are three large sweet potato processing plants in North Carolina. One of these plants produces dehydrated sweet potato flakes, using

a flaking procedure developed at North Carolina State University.

Sweet potato chips are in the advanced stage of development at North Carolina State University. This product shows promise of becoming a highly desirable snack food similar to potato chips.

At this stage, the postharvest problems of sweet potatoes probably require more attention than any other single area of this crop. The education of handlers and consumers is needed to promote proper handling and storage conditions (especially temperatures) for enhanced

sweet potato quality maintenance and further reduction of losses.

Covington, H. M. *Pre-sprouting sweet potatoes*. North Carolina Extension Service, Hort. Info. Leaf. 104, 1962.

North Carolina State University. *North Carolina agricultural chemicals manual*. North Carolina State University, Agricultural Experiment Station and Cooperative Extension Service, Raleigh, N.C., 1976.

Walters, W. M., Purcell, A. E., and Nelson, A. M. *Effects of amylolytic enzymes on "moistness" and carbohydrate change of baked sweet potato cultivars*. *J. Food Sci.* 40, 1975, 793-796.

## Sweet Potato Production in Hawaii

J. S. Tanaka and T. T. Sekioka<sup>1</sup>

This paper describes the general cultural practices of sweet potato production in Hawaii. Presented are cultivars grown, method of planting, fertilizer application, pest control, harvesting, and factors contributing to increased yield.

There are two types of sweet potatoes (*Ipomoea batatas*) grown for the market. The type referred to as sweet potato in Hawaii is dry-fleshed with white to pale yellow or purple flesh and is used mostly for boiling or frying. The other type, popularly called "yam," is moist-fleshed with orange flesh and used mostly for baking.

The sweet potato is grown all year round and is planted on all islands, with 71% being grown on the island of Oahu. Approximately 20 ha of sweet potato are harvested yearly with a production of 373 tons. Data for sweet potato production in Hawaii from 1965 to 1974 can be found in "Statistics of Hawaiian Agriculture, 1974." Approximately 246 tons of sweet potato are imported to the state of Hawaii annually from the United States mainland.

### Cultivars

There are dozens of native clones of sweet potato in Hawaii. Many of these clones are still grown to a limited extent. Kona B is the best-yielding baking or yam-type sweet potato, whereas Waimanalo Red is the earliest, best-yielding, highest quality dry type. Other moist

type cultivars are Iliula and Onolena, whereas other dry-type cultivars are HSPA-3, Miyashiro, and Kaneohe Red. All of the cultivars mentioned above are of local origin except Waimanalo Red, which was introduced from Okinawa.

### Planting

The sweet potato is propagated by means of tip cuttings in Hawaii because planting materials are available throughout the year and tip cuttings are relatively free from vine borers and diseases. The cuttings are about 8-12 inches in length with all except two or three of the terminal leaves removed from the vine.

The cuttings are planted at an angle with two-thirds of the stalks covered with soil. They are spaced 6-12 inches apart in the rows, with rows set 3 ft apart. Close spacing of plants in the rows encourages the development of roots that are of the best shape and size for the market. Wider spacings tend to produce extra large roots that are a lower grade and thus fetch a lower price.

### Fertilizer Applications

A fertilizer with a medium amount of nitrogen and phosphate and a great amount of potash is best. Rates (kg/ha) of fertilizer recommended are: N 40-50, P<sub>2</sub>O<sub>5</sub> 70-110, and K<sub>2</sub>O 70-110.

<sup>1</sup>University of Hawaii, Honolulu, Hawaii 96822. Paper published with the approval of the Director of the Hawaii Agricultural Experiment Station as Journal Series No. 2011.

a flaking procedure developed at North Carolina State University.

Sweet potato chips are in the advanced stage of development at North Carolina State University. This product shows promise of becoming a highly desirable snack food similar to potato chips.

At this stage, the postharvest problems of sweet potatoes probably require more attention than any other single area of this crop. The education of handlers and consumers is needed to promote proper handling and storage conditions (especially temperatures) for enhanced

sweet potato quality maintenance and further reduction of losses.

Covington, H. M. *Pre-sprouting sweet potatoes*. North Carolina Extension Service, Hort. Info. Leaf. 104, 1962.

North Carolina State University. *North Carolina agricultural chemicals manual*. North Carolina State University, Agricultural Experiment Station and Cooperative Extension Service, Raleigh, N.C., 1976.

Walters, W. M., Purcell, A. E., and Nelson, A. M. *Effects of amylolytic enzymes on "moistness" and carbohydrate change of baked sweet potato cultivars*. *J. Food Sci.* 40, 1975, 793-796.

## Sweet Potato Production in Hawaii

J. S. Tanaka and T. T. Sekioka<sup>1</sup>

This paper describes the general cultural practices of sweet potato production in Hawaii. Presented are cultivars grown, method of planting, fertilizer application, pest control, harvesting, and factors contributing to increased yield.

There are two types of sweet potatoes (*Ipomoea batatas*) grown for the market. The type referred to as sweet potato in Hawaii is dry-fleshed with white to pale yellow or purple flesh and is used mostly for boiling or frying. The other type, popularly called "yam," is moist-fleshed with orange flesh and used mostly for baking.

The sweet potato is grown all year round and is planted on all islands, with 71% being grown on the island of Oahu. Approximately 20 ha of sweet potato are harvested yearly with a production of 373 tons. Data for sweet potato production in Hawaii from 1965 to 1974 can be found in "Statistics of Hawaiian Agriculture, 1974." Approximately 246 tons of sweet potato are imported to the state of Hawaii annually from the United States mainland.

### Cultivars

There are dozens of native clones of sweet potato in Hawaii. Many of these clones are still grown to a limited extent. Kona B is the best-yielding baking or yam-type sweet potato, whereas Waimanalo Red is the earliest, best-yielding, highest quality dry type. Other moist

type cultivars are Iliula and Onolena, whereas other dry-type cultivars are HSPA-3, Miyashiro, and Kaneohe Red. All of the cultivars mentioned above are of local origin except Waimanalo Red, which was introduced from Okinawa.

### Planting

The sweet potato is propagated by means of tip cuttings in Hawaii because planting materials are available throughout the year and tip cuttings are relatively free from vine borers and diseases. The cuttings are about 8-12 inches in length with all except two or three of the terminal leaves removed from the vine.

The cuttings are planted at an angle with two-thirds of the stalks covered with soil. They are spaced 6-12 inches apart in the rows, with rows set 3 ft apart. Close spacing of plants in the rows encourages the development of roots that are of the best shape and size for the market. Wider spacings tend to produce extra large roots that are a lower grade and thus fetch a lower price.

### Fertilizer Applications

A fertilizer with a medium amount of nitrogen and phosphate and a great amount of potash is best. Rates (kg/ha) of fertilizer recommended are: N 40-50, P<sub>2</sub>O<sub>5</sub> 70-110, and K<sub>2</sub>O 70-110.

<sup>1</sup>University of Hawaii, Honolulu, Hawaii 96822. Paper published with the approval of the Director of the Hawaii Agricultural Experiment Station as Journal Series No. 2011.

### Weeding

Weeds are controlled with the use of herbicides such as diphenamid and dacthal. Once the vines close in, weeds are no longer a problem.

### Insect Control

The insects that most commonly attack sweet potato are: weevils, stem borers, and red spider mites. There are two types of weevils. One is a small, grayish type known as the West Indian sweet potato weevil (*Euscepes postfaciatus* Furr) and the other is a larger metallic blue-coloured weevil, with an orange-coloured thorax called *Cylas* sweet potato weevil (*Cylas formicarius elegantus* Sum). Control of the weevils is by dipping the cuttings in diazinon before planting, by rotation of the crop, and by spraying with diazinon. Stem borers are controlled by spraying with diazinon and mites by sulfur dusts or sprays.

### Disease

Diseases of sweet potato are usually not serious in Hawaii because most of the plantings are done by disease-free tip cuttings. In some areas, leaf scab caused by *Sphaceloma batatas* has caused abandonment of sweet potato plantings. No control of this disease is known.

### Harvesting

Sweet potatoes are ready for harvesting 4–6 months after planting. The vines are usually cut at the base and either removed or rolled over into the aisles before digging, usually with a middlebuster (double moldboard plow) or,

on a smaller scale, with a spading fork or 4- to 6-pronged potato hoe.

## Factors Contributing to Increased Yield

### Cultivar Improvements

Introduction and the polycross method of breeding have been used successfully in Hawaii. The primary objectives of the breeding program are high yield, early maturity, red skin colour, and minimal vine growth. Recently, high carotene has become another goal.

### Cultural Practices

Aside from the use of improved cultivars, the adoption of improved cultural practices has played a significant role in the steady increase of sweet potato yield. These are: (1) better use of fertilizer; (2) timely irrigation in nonirrigated fields; and (3) better control of the sweet potato weevils (*Cylas formicarius elegantus* Sum and *Euscepes postfaciatus* Furr). Further improvements in yield may be attained through: (1) reducing the growth period of 5–6 months to 4–4.5 months (the incorporation of early maturity with other horticultural characteristics is one of the goals of the breeding program); and (2) mechanization of most production phases (because of increased costs and shortage of labour).

Joint efforts among plant breeders, phytopathologists, entomologists, agricultural engineers, and economists are necessary to ensure the progress of sweet potato production in Hawaii.

---

## IBPGR and FAO Programs for the Collection of Crop Germ Plasm and its Long-Term Conservation

J. T. Sykes<sup>1</sup>

FAO's program in genetic resources started in 1961. Advised by the FAO Panel of Experts on Plant Exploration and Introduction, standards and procedures for long-term conservation of base collections were proposed in

1975 that included recommended condition for storage of "orthodox" seeds. Institutions that maintain "base" or "active" collections were determined by an FAO survey. Many of these institutions are willing to provide space for international storage. However, regions that have few stores of base collection standard include Africa, South and Southeast Asia, and Meso-America. Ideally, "orthodox" seed, stored ac-

---

<sup>1</sup>Crop Ecology and Genetic Resources Service, Plant Production and Protection Division, FAO, Rome, Italy.

### Weeding

Weeds are controlled with the use of herbicides such as diphenamid and dacthal. Once the vines close in, weeds are no longer a problem.

### Insect Control

The insects that most commonly attack sweet potato are: weevils, stem borers, and red spider mites. There are two types of weevils. One is a small, grayish type known as the West Indian sweet potato weevil (*Euscepes postfaciatus* Furr) and the other is a larger metallic blue-coloured weevil, with an orange-coloured thorax called *Cylas* sweet potato weevil (*Cylas formicarius elegantus* Sum). Control of the weevils is by dipping the cuttings in diazinon before planting, by rotation of the crop, and by spraying with diazinon. Stem borers are controlled by spraying with diazinon and mites by sulfur dusts or sprays.

### Disease

Diseases of sweet potato are usually not serious in Hawaii because most of the plantings are done by disease-free tip cuttings. In some areas, leaf scab caused by *Sphaceloma batatas* has caused abandonment of sweet potato plantings. No control of this disease is known.

### Harvesting

Sweet potatoes are ready for harvesting 4–6 months after planting. The vines are usually cut at the base and either removed or rolled over into the aisles before digging, usually with a middlebuster (double moldboard plow) or,

on a smaller scale, with a spading fork or 4- to 6-pronged potato hoe.

## Factors Contributing to Increased Yield

### Cultivar Improvements

Introduction and the polycross method of breeding have been used successfully in Hawaii. The primary objectives of the breeding program are high yield, early maturity, red skin colour, and minimal vine growth. Recently, high carotene has become another goal.

### Cultural Practices

Aside from the use of improved cultivars, the adoption of improved cultural practices has played a significant role in the steady increase of sweet potato yield. These are: (1) better use of fertilizer; (2) timely irrigation in nonirrigated fields; and (3) better control of the sweet potato weevils (*Cylas formicarius elegantus* Sum and *Euscepes postfaciatus* Furr). Further improvements in yield may be attained through: (1) reducing the growth period of 5–6 months to 4–4.5 months (the incorporation of early maturity with other horticultural characteristics is one of the goals of the breeding program); and (2) mechanization of most production phases (because of increased costs and shortage of labour).

Joint efforts among plant breeders, phytopathologists, entomologists, agricultural engineers, and economists are necessary to ensure the progress of sweet potato production in Hawaii.

---

## IBPGR and FAO Programs for the Collection of Crop Germ Plasm and its Long-Term Conservation

J. T. Sykes<sup>1</sup>

FAO's program in genetic resources started in 1961. Advised by the FAO Panel of Experts on Plant Exploration and Introduction, standards and procedures for long-term conservation of base collections were proposed in

1975 that included recommended condition for storage of "orthodox" seeds. Institutions that maintain "base" or "active" collections were determined by an FAO survey. Many of these institutions are willing to provide space for international storage. However, regions that have few stores of base collection standard include Africa, South and Southeast Asia, and Meso-America. Ideally, "orthodox" seed, stored ac-

---

<sup>1</sup>Crop Ecology and Genetic Resources Service, Plant Production and Protection Division, FAO, Rome, Italy.

ording to a prescribed "preferred" standard, reduces the need for frequent regeneration of accessions. Capital and operating costs of stores at sub-zero temperature, thought to be not excessive, need to be quantified and further refined.

The International Board for Plant Genetic Resources (IBPGR) was established in 1974. Its basic objective is to promote an international network of genetic resources activities. Free exchange of material and information related to it, the deposition of duplicate collections in their country of origin, and the duplication of "base" collections are three basic

principles that the Board has adopted.

IBPGR has established two dimensions of crops and regions as a matrix for its priorities. Cassava, potato, sweet potato, and yam are among the tropical root and tuber crops to which priorities have been assigned in 10 of the 14 designated regions. The IBPGR is promoting germ plasm collections of tuber and root crops, grain legumes, millet, and rice in West Africa; cereals in North Africa, India, and Pakistan; rice in Southeast Asia; and potato, tropical forage legumes and grasses, maize, and groundnuts in Latin America.

---

## Summary of Discussions

### Basic Productivity

Rapporteur: James Cock

Discussion Leaders: James Cock, Brown Enyi, and Bede Okigbo

The similarity between tropical and temperate root crops is tremendous, and much of the sophisticated work done in temperate regions can form a base for tropical root crop investigation. The root crops, unlike the cereals and many other crops that have their sexual organs as the usable parts, produce the source and fill their sink at the same time. This means that there is always a balance between production of source and filling of the sink, and any increase in source size will be made at the expense of the sink.

This situation means that optimum leaf area indices for root and tuber crop yields may not be very high (i.e. 3-4) and hence leaf angle and canopy structure may not be important. Work on cassava and sweet potato support this hypothesis but in *Tania* higher yields are related to greater leaf area durations. The primary productivity of the crop may not be as important as the partitioning in tropical root and tubers crops; this agrees with Dr Loomis' thinking in the case of sugar beet. In the root crops, very high plant populations tend to increase primary productivity but decrease partitioning to the roots and decrease yield.

The ideal would seem to be a crop that has a very rapid leaf area index build up and once this is formed it should be maintained by a long leaf life with nearly all new production of dry matter being used in the production of roots and tubers. This may be very difficult as types in which leaf growth is dominant at the early growth stages maintain this dominance throughout the whole cycle.

Various attempts to correlate yield with net assimilations rate and photosynthesis are dangerous and often invalid. A plant that has medium LAI will have a higher yield, due to better dry matter distribution, than a very high LAI crop in many cases. The medium LAI crop will also have a higher net assimilation rate and hence a spurious correlation between yield and net assimilation rate. Similarly, trying to relate yield to photosynthetic rate of sink limited crops, as has been tried in corn and soya, is obviously futile.

Frequently, workers are exhorted to produce high protein root and tuber crops, but there is found to be negative effect on yield due to the extra energy needed to produce protein when compared with starch. When starch is stored, it should be

ording to a prescribed "preferred" standard, reduces the need for frequent regeneration of accessions. Capital and operating costs of stores at sub-zero temperature, thought to be not excessive, need to be quantified and further refined.

The International Board for Plant Genetic Resources (IBPGR) was established in 1974. Its basic objective is to promote an international network of genetic resources activities. Free exchange of material and information related to it, the deposition of duplicate collections in their country of origin, and the duplication of "base" collections are three basic

principles that the Board has adopted.

IBPGR has established two dimensions of crops and regions as a matrix for its priorities. Cassava, potato, sweet potato, and yam are among the tropical root and tuber crops to which priorities have been assigned in 10 of the 14 designated regions. The IBPGR is promoting germ plasm collections of tuber and root crops, grain legumes, millet, and rice in West Africa; cereals in North Africa, India, and Pakistan; rice in Southeast Asia; and potato, tropical forage legumes and grasses, maize, and groundnuts in Latin America.

---

## Summary of Discussions

### Basic Productivity

Rapporteur: James Cock

Discussion Leaders: James Cock, Brown Enyi, and Bede Okigbo

The similarity between tropical and temperate root crops is tremendous, and much of the sophisticated work done in temperate regions can form a base for tropical root crop investigation. The root crops, unlike the cereals and many other crops that have their sexual organs as the usable parts, produce the source and fill their sink at the same time. This means that there is always a balance between production of source and filling of the sink, and any increase in source size will be made at the expense of the sink.

This situation means that optimum leaf area indices for root and tuber crop yields may not be very high (i.e. 3-4) and hence leaf angle and canopy structure may not be important. Work on cassava and sweet potato support this hypothesis but in *Tania* higher yields are related to greater leaf area durations. The primary productivity of the crop may not be as important as the partitioning in tropical root and tubers crops; this agrees with Dr Loomis' thinking in the case of sugar beet. In the root crops, very high plant populations tend to increase primary productivity but decrease partitioning to the roots and decrease yield.

The ideal would seem to be a crop that has a very rapid leaf area index build up and once this is formed it should be maintained by a long leaf life with nearly all new production of dry matter being used in the production of roots and tubers. This may be very difficult as types in which leaf growth is dominant at the early growth stages maintain this dominance throughout the whole cycle.

Various attempts to correlate yield with net assimilations rate and photosynthesis are dangerous and often invalid. A plant that has medium LAI will have a higher yield, due to better dry matter distribution, than a very high LAI crop in many cases. The medium LAI crop will also have a higher net assimilation rate and hence a spurious correlation between yield and net assimilation rate. Similarly, trying to relate yield to photosynthetic rate of sink limited crops, as has been tried in corn and soya, is obviously futile.

Frequently, workers are exhorted to produce high protein root and tuber crops, but there is found to be negative effect on yield due to the extra energy needed to produce protein when compared with starch. When starch is stored, it should be

stored in such a manner that its maintenance respiration is low. The whole relationship between photosynthesis and respiration needs further study.

The use of models to describe plant growth has certain limitations due to the difficulties of describing canopy structure in complex branching crops. Nevertheless, a model is a useful tool for defining plant types and assessing the physiological effects of diseases and pests on the plant. In cotton, the yield losses due to insect attack have been assessed very accurately by model.

Translocation has been cited as limiting yield, but there is little evidence for this in the root crops. In sugar beet, no substrate build up effect on photosynthesis could be induced.

The effects of photoperiod need more study, especially the way in which they change partitioning.

It is a tragedy that there are not more breeder physiologists, and in general in the tropical regions there are few crop physiologists. Physiology teaching stops at the level of one plant and makes little effort to describe the situation in a plant community.

# Cassava Diseases and Their Control

J. C. Lozano and E. R. Terry<sup>1</sup>

For the purposes of control, cassava pathogens are classified as (a) those that attack vegetative propagating material, (b) those that attack foliage and green stem portions, and (c) root rot pathogens that can induce preharvest and postharvest deterioration. Control measures for each of these categories are discussed and recommendations are made. These measures, however, should be applied as part of an integrated system for any cassava cultivation program.

Until recently cassava was considered to be resistant to diseases and pests; it is now accepted that diseases can cause severe losses and that they are economically important. Cassava is affected by more than 30 fungal, bacterial, viral, or viruslike and mycoplasmal agents (Lozano and Booth 1974). These diseases can affect plant establishment and vigour, inhibit photosynthetic efficiency, or cause preharvest or postharvest deterioration. Some causal agents are distributed worldwide, appearing endemically in almost all cassava plantations (leaf spots induced by *Cercospora* spp. and *Oidium* spp.) (Lozano 1976; Terry 1975a). Others are limited to geographical areas or continents (the causal agents of cassava bacterial blight, American viruses, and mycoplasmal diseases) (Lozano 1972, 1975), possibly because their dissemination occurs mainly through the use of infected planting material for propagation.

African mosaic disease and brown streak virus are limited to Africa (Lozano 1972; Terry 1975a), Asian mosaic disease to Asia, and superelongation disease to America (Lozano and Booth 1974; Lozano 1972). Apparently the causal agents of African and Asian mosaic diseases are not present in America, although the vector (*Bemisia* spp.) was recently identified on this continent (Bellotti personal communication). Other widely distributed pathogens attack cassava only during the cool and rainy periods of the year or in areas located at high elevations (more than 1200 m), where

temperatures are below 22 °C (*Phoma* sp. and *Cercospora caribaea*) (Lozano and Booth 1974; CIAT 1974, 1975). There are other pathogens whose incidence is limited by environmental conditions, possibly because they require high relative humidity (nearly to the saturation point) for germination and establishment (CIAT 1974).

## Pathogens of Vegetative Material

Cassava is vegetatively propagated by planting pieces of stem cuttings; consequently, cassava pathogens can be disseminated easily by the movement of planting material from infected to uninfected areas. These pathogens can cause considerable damage during the establishment of the crop or at any time during its growth cycle, including: (1) reduction in germination, (2) damping off, (3) decrease of normal plant vigour, and (4) reduction of the potential number of swollen roots due to initial root damage.

These pathogens are mainly fungi, which attack epidermal, cortical, and woody stem tissues (*Sphaceloma manihoticola*, *Gloeosporium* sp.); facultative saprophytes or parasites (*Rosellinia necatrix*, *Fusarium* spp., *Armillaria mellea*, *Sclerotinia* sp., *Sclerotium rolfsii*, *Penicillium* spp., *Aspergillus* spp., etc.). These fungi are frequently found in the soil (Lozano and Booth 1974). Other pathogens include (1) bacteria (*Xanthomonas manihotis*, Lozano 1975; or *Erwinia* sp., Lozano et al. 1976; CIAT 1976), (2) mycoplasma, and (3) viruses or viruslike diseases (Lozano 1972; Terry 1975a). These are generally vascular pathogens located inside pieces of stem used for propagation.

The occurrence of these pathogens in a plan-

<sup>1</sup>Centro Internacional de Agricultura Tropical, Apartado Aéreo 67-13, Cali, Colombia, and International Institute of Tropical Agriculture, P.M.B. 5320, Ibadan, Nigeria, respectively.

tation may be due to the use of planting material taken from infected plantations (Lozano 1972, 1975), the use of infested machinery or tools during the preparation of land and while planting stem pieces, or infested soils.

### Control Measures

Taking the foregoing factors into consideration, the incidence of these pathogens in a country, region, or plantation can be prevented by following these recommendations:

(1) A careful selection of all planting material must be initiated by choosing the appropriate area and field for the collection of propagating material. Once in the field, plants and plant sections used for propagation should also be carefully selected. Generally, it is not advisable to take planting material from Africa or Asia to America due to the presence of mosaic disease in the former. Cuttings should not be taken from areas where CBB or superelongation disease is present. The use of cuttings from plantations infected with the common mosaic or vein mosaic virus and mycoplasmal diseases must also be avoided (IDRC 1975; Lozano 1976; Terry 1975a). Cuttings should always be selected from vigorous, apparently healthy plants. The elimination of any stem section with suspicious signs of disease is extremely important in the control of these diseases.

(2) Avoid damage to vegetative propagating material. Germination and establishment can also be improved by the careful handling of cuttings during preparation, packing, shipping, and planting, which prevents injury to both the stem and bud tissues. Some vascular pathogens of cassava are disseminated by the use of infected tools. When handling propagative material, all tools and machinery should be disinfected prior to each use with a 5% solution of commercial formaldehyde.

Fungicide "seed" treatment of cuttings may be valuable. Germination and establishment can be increased by more than 10% by dipping cassava cuttings into a 5% solution of Demosan (1,4 dichloro-2,5-dimethoxybenzene), Arasan (tetramethylthiuram disulfide), Agalol (methoxyethylmercury chloride) or Brasicol 75 (pentachloronitrobenzene) for 3-5 min before planting (CIAT 1974).

(3) Selection and preparation of land are also important factors for successful cassava cultivation. Heavy soils, with a high organic matter content, are difficult to drain and may

remain flooded for several hours after a heavy rainfall. These soils may also contain high populations of organisms that can attack the recently planted cuttings. Land that has been previously used for forest (woody trees, bushes, coffee, etc.) or perennial crops (plantain, sugar cane, etc.) may also contain high populations of root rot pathogens (e.g. *Rosellinia necatrix*, *Armillaria mellea*, *Fusarium* spp., *Sclerotium rolfsii*, *Rhizoctonia* sp., *Pythium* spp., *Fomes lignosus*, *Phytophthora drechsleri*, etc.), which normally attack cassava roots and woody stems (Lozano and Booth 1974).

Adequate cultural practices to ensure good soil preparation and drainage should always be followed. Planting on ridges may also be effective in preventing diseases. Soil must be well plowed and drained. In regions where rainfall is high (more than 1200 mm), planting should be done on ridges to improve drainage and reduce root damage.

Good quality cuttings, about 20 cm long, should be planted so that half the cutting is covered by soil. Water should be applied soon after planting.

### Foliar and Green Stem Pathogens

Several fungi (*Cercospora* spp., *Phoma* sp., *Oidium* sp., *Colletotrichum gloeosporioides*, *Uromyces* spp., etc.), bacteria (*Xanthomonas manihotis* and *Erwinia* sp.), mycoplasma, and viruses or viruslike causal agents attack the leaves and green stem portions of the plant, or show the most characteristic symptoms in these areas. Damage induced by these agents can lead to a reduction of photosynthesis, thereby decreasing the production and storage of carbohydrates. Reduction in photosynthesis can result from: (1) leaf spotting (chlorotic or necrotic areas) induced by certain fungi, viruses, viruslike causal agents, and bacteria; (2) blight and dieback induced by certain bacteria and fungi; (3) distortion and leaf stunting induced by certain mycoplasma, viruses, and viruslike agents; (4) bud proliferation induced by mycoplasma; and (5) hypertrophy caused by certain variants of mycoplasma (Costa and Kitajima 1972) and the superelongation causal agent (Lozano and Booth 1974; Krausz et al. 1976).

Several pathogens included in this group are endemic in major cassava-growing areas (Lozano and Booth 1974; Terry 1975a). Disease severity appears to be related to susceptibility

of the cultivar and climatic conditions in each area.

Some other causal agents that can be disseminated mechanically or by using diseased planting material are viruses and mycoplasma, found scattered in certain regions of America but whose incidence is low. Cassava bacterial blight, superelongation disease, and African mosaic disease are also disseminated by infected planting material (Lozano 1975; Krausz et al. 1976; CIAT 1976; Lozano 1972). However, since their specific means of dissemination are highly effective, they may suddenly spread in a given region, country, or continent, causing serious epiphytotic a relatively short time after their introduction (Lozano and Sequeira 1974; Terry 1975b).

### Control Measures

The control measures suggested for the diseases induced by the aforementioned group of causal agents are:

(1) *Varietal resistance*. Even though there are no resistant commercial cultivars for many cassava diseases, good sources of resistance have been identified and promising hybrids are now being multiplied by IITA and CIAT (IITA 1973, 1974; CIAT 1974, 1975). Resistant genotypes for CBB, *Cercospora* leaf spots, superelongation disease, and *Phoma* leaf spot have been tested during several growing cycles. Good-yielding commercial lines, resistant to the major cassava diseases, should be available in the near future.

(2) *Disease-free planting material*. This is the best control measure to prevent the introduction of causal agents that attack vascular and cortical tissues. These causal agents include viruses or viruslike diseases (common mosaic virus, vein mosaic virus, and African mosaic disease), mycoplasma (witches' broom disease), bacteria (*X. manihotis* and *Erwinia* sp.), and epidermal and cortical fungi (*Sphaeloma manihoticola*, etc.). Methods for producing CBB-free planting material have been developed at CIAT (Lozano and Wholey 1974; Takatzu and Lozano 1975; Cock et al. 1976). The culture of meristematic tissues has also been reported (Kartha and Gamborg 1975). Both techniques are useful tools for producing disease-free planting material. They could be used to supply basic stock for the rapid multiplication method recently reported by Cock et al. (1976).

(3) *Roguing*. Pathogens reported to be dis-

seminated mechanically from diseased to healthy plants (Costa and Kitajima 1972; Lozano 1972) can be eliminated by roguing. The common mosaic virus, the vein mosaic virus, and the witches' broom mycoplasma diseases are also included in this group. Rogued plants must be destroyed by fire. We also suggest that tool surfaces be sterilized.

(4) *Cultural practices*. Within a few days after planting, the cassava foliar system provides a microclimate with lower temperatures, high relative humidity, and low air circulation between the ground surface and the top of the plants. The formation of this microclimate depends upon the variety planted (varieties with low or high leaf area index), as well as on the plant population. These conditions may favour the incidence and severity of fungal and bacterial foliar diseases such as *Cercospora* leaf spots, *Phoma* leaf blight, cassava bacterial blight, etc. Their incidence and severity may be reduced by selecting varieties with low leaf area index. Plant population and foliar index should be just high enough to supply satisfactory weed control and good yield. A leaf area index of about 3 appears to be optimal for root yield (Cock personal communication; CIAT 1975, 1976). Appropriate planting time may also reduce the incidence of these diseases; planting at the beginning of the rainy season ensures good establishment. The canopy will close across the rows during the dry season, approximately 4 months after planting. Because of the dry environment, a favourable microclimate for these pathogens will not be formed.

### Root Rot Pathogens

Cassava roots often deteriorate before or after harvesting. Preharvest root rot is the result of attack by soil-borne pathogens. Postharvest root rot appears to be a combination of physiological-pathological factors, generally accelerated by mechanical injury to the roots during the harvesting operations (Booth 1975).

#### Preharvest Root Rot

The appearance of preharvest root rot problems in a cassava plantation is generally a result of using poor-quality, diseased cuttings. Inadequate preparation of the land can also result in preharvest root rot. Therefore, the aforementioned recommendations for selection and treatment of cuttings before planting and

the cultural practices suggested for land selection, preparation, and maintenance should be strictly observed to prevent or reduce root rot incidence. If root rots increase to levels higher than 3%, which is considered to be economically important, crop rotation with cereals (maize, sorghum, etc.) or crop fallowing for a 6-month period is also recommended. These practices should decrease the inoculum potential of root rot pathogens; however, effective control of these diseases through the use of crop rotation or crop fallowing has not been demonstrated. It is possible that longer periods of rotation or crop fallowing are needed in order to decrease the incidence of pathogens that produce resting structures, such as sclerotia, chlamydo-spores, rhizomorphs, etc. It has also been observed that some cultivars are more susceptible to root rot diseases than others. The development of resistant cultivars could be considered for the control of these diseases.

### Postharvest Root Rot

Cassava roots cannot be kept in a fresh state for more than a few days after harvest if certain precautions are not taken. This presents serious problems in the marketing and utilization of the crop and results in heavy losses. Two types of deterioration have been reported (CIAT 1974, 1975; Booth 1973): physiological or pathogenic, or a combination of the two.

Several control measures to reduce postharvest deterioration have been suggested:

(1) Leave the roots in the ground until needed. Once harvested, the roots should be used immediately or dried for longer storage life. This necessitates a scheduled program of planting and processing.

(2) The rate of primary deterioration varies among cultivars (Montaldo 1973; Booth, Noon, and Kawano, personal communication), so those which display the slowest rate of deterioration should be used.

(3) One of the most important factors in the success of cassava storage is the condition of the product to be stored (Booth 1975). Care should be taken during harvesting and handling to minimize damage, and only the least damaged roots should be stored.

(4) Deterioration can be delayed by the use of various surface sterilants and fungicides (Booth 1975), refrigeration and waxing (Singh and Mathur 1953; IIT, 1973). However, the

high cost and low efficiency of these techniques severely limit their use.

(5) Small quantities of roots can be preserved for several days by using simple techniques such as reburial, or coating in mud and placing under water. Burying the roots in a trench or covering them with soil or a mixture of straw and soil gives good results (Ingram and Humphries 1972). Booth (1975) was able to store roots for up to 3 months in field clamps similar to those used for storing potatoes in Europe. He also reported that cassava could be stored in boxes with moist sawdust at room temperature. As a result of this research, it was concluded that cassava roots, like many other root and tuber crops, can be cured, requiring only high relative humidities at temperatures between 25 and 40 °C.

### Conclusions

There are very few economically feasible chemical control measures for cassava diseases. The most practical control methods are to: (1) plant disease-resistant cultivars; (2) use adequate cultural practices; and (3) plant disease-free material treated with fungicide. At present cassava improvement programs are concerned with long-term research to produce and release high-yielding multiple-disease-resistant cultivars. This will take some time; however, the foregoing recommendations should provide effective short-term control, which should minimize the incidence and spread of cassava diseases.

Booth, R. H. *The storage of fresh cassava roots*. In Proc. International Symposium on Tropical Root and Tuber Crops. Ibadan, Nigeria, 1973 (in press).

*Cassava storage*. CIAT, Cali, Colombia, Bulletin EE-16, 1975, 18 p.

CIAT *Annual Report 1973*. CIAT, Cali, Colombia, 1974, 260 p.

*Annual Report 1974*. CIAT, Cali, Colombia, 1975, 253 p.

*Sistemas de producción de yuca*. In Informe Anual CIAT 1975, CIAT, Cali, Colombia, 1976, 63 p.

Cock, J. H., Wholey, D. W., and Lozano, J. C. *A rapid propagation system for cassava*. CIAT, Cali, Colombia, Bulletin EE-20, 1976, 11 p.

Costa, A. S., and Kitajima, E. W. *Studies on virus and mycoplasma diseases of the cassava plant in Brazil*. In Proceedings IDRC/IITA Cassava Mosaic Workshop, International Institute of Tropical Agriculture, Ibadan, Nigeria, 1972, 48 p.

- IDRC *The international exchange and testing of cassava germ plasm. Proceedings of an interdisciplinary workshop held at CIAT, Palmira, Colombia, 4-6 February 1975.* International Development Research Centre, IDRC-049e, 1975, 74 p.
- IIT *La yuca parafinada.* Revista del IIT (Colombia), 78, 1973, 131-148.
- IITA *Root and tuber improvement program.* In Annual Report 1973. IITA, Ibadan, Nigeria, 1974, 39 p.
- Annual Report 1974.* IITA, Ibadan, Nigeria, 1975, 199 p.
- Ingram, J. S., and Humphries, J. R. O. *Cassava storage: a review.* Tropical Science, 14, 1972, 131-148.
- Kartha, K. K., and Gamborg, O. L. *Elimination of cassava mosaic disease by meristem culture.* Phytopathology, 65, 1975, 826-828.
- Krausz, J. *The superelongation disease of cassava.* PhD thesis, Cornell University, Ithaca, N.Y., 1975, 81 p.
- Krausz, J., Lozano, J. C., and Thurston, H. D. *A new anthracnose-like disease of cassava.* Ann. Proc. of the Am. Phytopath. Soc. 1976 (in press).
- Lozano, J. C. *Status of virus and mycoplasma-like disease of cassava.* In Proceedings of the IDRC/IITA cassava mosaic workshop, International Institute of Tropical Agriculture, Ibadan, Nigeria, 1972, 48 p.
- Lozano, J. C., and Booth, R. H. *Diseases of cassava (Manihot esculenta Crantz).* PANS (Pest Articles and News Summaries), Centre for Overseas Pest Research, London, 20, 1974, 30-54.
- Lozano, J. C., and Sequeira, L. *Bacterial blight of cassava in Colombia: epidemiology and control.* Phytopathology, 64, 1974, 83-88.
- Lozano, J. C., and Wholey, D. W. *The production of bacteria-free planting stock of cassava.* World Crops, 26, 1974, 115-117.
- Lozano, J. C. *Bacteria blight of cassava.* PANS (Pest Articles and News Summaries), Centre for Overseas Pest Research, London, 21, 1975, 38-43.
- The threat of introducing cassava diseases and pests on propagation material.* In Plant health and quarantine problems arising in international genetic resources transfer. FAO (Food and Agriculture Organization), 1976 (in press).
- Lozano, J. C., Bellotti, A., van Schoonhoven, A., Howeler, R., Howell, D., and Doll, J. *Field problems in cassava.* CIAT (Centro Internacional de Agricultura Tropical), Cali, Colombia, 1976.
- Montaldo, A. *Vascular streaking of cassava root tubers.* Tropical Science, 15, 1973, 39-46.
- Singh, K. K., and Mathur, P. B. *Cold storage of tapioca roots.* Central Food Technological Research Institute, Mysore, India, Bulletin, 2, 1953, 181-182.
- Takatsu, A., and Lozano, J. C. *Translocación del agente causal del añublo bacterial de la yuca (Manihot esculenta Crantz) en los tejidos del hospedero.* Fitopatología, 10, 1975, 13-22.
- Terry, E. R. *Cassava germ plasm resources, disease incidence, and phytosanitary constraints at IITA.* In Nestel, B., and MacIntyre, R., eds., The international exchange and testing of cassava germ plasm, *Proceedings of an interdisciplinary workshop held at CIAT, Palmira, Colombia, 4-6 February 1975.* IDRC-049e, 1975a, 38-40.
- Cassava bacterial blight disease in Africa.* In Proceedings of the IDRC/IITA Workshop on Cassava Improvement in Africa. International Institute of Tropical Agriculture, Ibadan, Nigeria, 1975b (in press).

## Field Control of Cassava Mosaic in Coast Province, Kenya

K. R. Bock, E. J. Guthrie, and A. A. Seif<sup>1</sup>

A series of simple observational trials to study the epidemiology of cassava mosaic in the field was undertaken at the Coast Agricultural Research Station, Mtwapa, during 1973-76 on moderately tolerant cultivar 46106/27 and highly susceptible cultivar F279. The results indicate that control of mosaic in the field in coastal districts of Kenya is possible by the use of mosaic-free planting material, the roguing of infected plants, and by allowing a reasonable degree of isolation of clean plots from infected plots. They also

<sup>1</sup>Bock and Guthrie, Ministry of Overseas Development Crop Virology Project, East African Agriculture and Forestry Research Organization, P.O. Box 30148, Nairobi, Kenya; Seif, Department of Agriculture, Coast Agricultural Research Station, P.O. Box 16, Kikambala, Kenya.

- IDRC *The international exchange and testing of cassava germ plasm. Proceedings of an interdisciplinary workshop held at CIAT, Palmira, Colombia, 4-6 February 1975.* International Development Research Centre, IDRC-049e, 1975, 74 p.
- IIT *La yuca parafinada.* Revista del IIT (Colombia), 78, 1973, 131-148.
- IITA *Root and tuber improvement program.* In Annual Report 1973. IITA, Ibadan, Nigeria, 1974, 39 p.
- Annual Report 1974.* IITA, Ibadan, Nigeria, 1975, 199 p.
- Ingram, J. S., and Humphries, J. R. O. *Cassava storage: a review.* Tropical Science, 14, 1972, 131-148.
- Kartha, K. K., and Gamborg, O. L. *Elimination of cassava mosaic disease by meristem culture.* Phytopathology, 65, 1975, 826-828.
- Krausz, J. *The superelongation disease of cassava.* PhD thesis, Cornell University, Ithaca, N.Y., 1975, 81 p.
- Krausz, J., Lozano, J. C., and Thurston, H. D. *A new anthracnose-like disease of cassava.* Ann. Proc. of the Am. Phytopath. Soc. 1976 (in press).
- Lozano, J. C. *Status of virus and mycoplasma-like disease of cassava.* In Proceedings of the IDRC/IITA cassava mosaic workshop, International Institute of Tropical Agriculture, Ibadan, Nigeria, 1972, 48 p.
- Lozano, J. C., and Booth, R. H. *Diseases of cassava (Manihot esculenta Crantz).* PANS (Pest Articles and News Summaries), Centre for Overseas Pest Research, London, 20, 1974, 30-54.
- Lozano, J. C., and Sequeira, L. *Bacterial blight of cassava in Colombia: epidemiology and control.* Phytopathology, 64, 1974, 83-88.
- Lozano, J. C., and Wholey, D. W. *The production of bacteria-free planting stock of cassava.* World Crops, 26, 1974, 115-117.
- Lozano, J. C. *Bacteria blight of cassava.* PANS (Pest Articles and News Summaries), Centre for Overseas Pest Research, London, 21, 1975, 38-43.
- The threat of introducing cassava diseases and pests on propagation material.* In Plant health and quarantine problems arising in international genetic resources transfer. FAO (Food and Agriculture Organization), 1976 (in press).
- Lozano, J. C., Bellotti, A., van Schoonhoven, A., Howeler, R., Howell, D., and Doll, J. *Field problems in cassava.* CIAT (Centro Internacional de Agricultura Tropical), Cali, Colombia, 1976.
- Montaldo, A. *Vascular streaking of cassava root tubers.* Tropical Science, 15, 1973, 39-46.
- Singh, K. K., and Mathur, P. B. *Cold storage of tapioca roots.* Central Food Technological Research Institute, Mysore, India, Bulletin, 2, 1953, 181-182.
- Takatsu, A., and Lozano, J. C. *Translocación del agente causal del añublo bacterial de la yuca (Manihot esculenta Crantz) en los tejidos del hospedero.* Fitopatología, 10, 1975, 13-22.
- Terry, E. R. *Cassava germ plasm resources, disease incidence, and phytosanitary constraints at IITA.* In Nestel, B., and MacIntyre, R., eds., The international exchange and testing of cassava germ plasm, *Proceedings of an interdisciplinary workshop held at CIAT, Palmira, Colombia, 4-6 February 1975.* IDRC-049e, 1975a, 38-40.
- Cassava bacterial blight disease in Africa.* In Proceedings of the IDRC/IITA Workshop on Cassava Improvement in Africa. International Institute of Tropical Agriculture, Ibadan, Nigeria, 1975b (in press).

## Field Control of Cassava Mosaic in Coast Province, Kenya

K. R. Bock, E. J. Guthrie, and A. A. Seif<sup>1</sup>

A series of simple observational trials to study the epidemiology of cassava mosaic in the field was undertaken at the Coast Agricultural Research Station, Mtwapa, during 1973-76 on moderately tolerant cultivar 46106/27 and highly susceptible cultivar F279. The results indicate that control of mosaic in the field in coastal districts of Kenya is possible by the use of mosaic-free planting material, the roguing of infected plants, and by allowing a reasonable degree of isolation of clean plots from infected plots. They also

<sup>1</sup>Bock and Guthrie, Ministry of Overseas Development Crop Virology Project, East African Agriculture and Forestry Research Organization, P.O. Box 30148, Nairobi, Kenya; Seif, Department of Agriculture, Coast Agricultural Research Station, P.O. Box 16, Kikambala, Kenya.

suggest that under the prevailing climatic conditions, man is a more efficient vector, by his use of infected cuttings, than a whitefly. Loss of yield due to mosaic in cv 46106/27 and cv F279 was 70 and 86%, respectively, and the drop in yield was significantly greater for cv F279 than for cv 46106/27.

Over a vast area of East Africa, cassava is far more important than estimates of acreage, Departmental Annual Reports, or export statistics would suggest. It is a staple food of a significant proportion of the population, and in the more arid areas it remains the only reserve against famine. The importance of cassava in East Africa was officially recognized many years ago, when the East African Agriculture and Forestry Research Organization (EAAFRO) mounted a major program of breeding and selection for resistance to cassava mosaic and cassava brown streak diseases. This program spanned a quarter of a century (from 1934 to 1960), and it yielded material of great value. Several selections from the program are widely planted and are among the most popular varieties in East Africa; others, notably *Manihot esculenta* × *M. glaziovii* hybrids backcrossed to *M. esculenta*, form the basis of resistance in international breeding programs such as at the International Institute of Tropical Agriculture, Ibadan.

None of the EAAFRO material can be described as immune to cassava mosaic, nor with very few exceptions can any varieties be described as highly resistant. For example, in 1972 at the Farmers' Training Centre, Mtwapa, we observed a 5-ha bulking plot of the "tolerant" variety 46106/27 that was totally infected with mosaic. In contrast, we had also observed several farmers' plots substantially free of mosaic, and this led us to consider the effect of planting mosaic-free material on the epidemiology of mosaic.

Accordingly, we carried out a series of simple observational trials designed to study the rate of spread of mosaic disease into initially healthy cassava. This paper reports the results of experiments carried out during the period 1973-76.

## Materials and Methods

Because our results hold for one climatic regime only (coastal districts of East Africa), it is necessary to give a brief summary of the climate at Mtwapa. The mean annual rainfall of approximately 1200 mm is bimodal; the so-called long rains falling in April to June, and

the short rains in October and November. Although most cassava is planted at the beginning of the long rains, it is possible to plant successfully in October or November. Temperature is never a limiting factor for growth, mean maximum being about 30 °C and mean minimum 22 °C. Growth is generally checked during the dry months (January to March) but the equable climate enables cassava to be harvested within 10-12 months of planting.

## Cassava Varieties

Two varieties of cassava were used: 46106/27, an EAAFRO selection (third back cross of a *glaziovii* × *esculenta* derivative to *esculenta*) and F279, an import from Java. Both varieties are popular because of high yields and good taste. They are both "sweet" cassavas and may be eaten raw.

46106/27 was released as a clone with a high level of resistance, and one that stood up to the exacting conditions at the coast (Doughty 1958). In our experience, however, plantings of the clone may become totally infected, and the reaction is moderately severe.

F279 is extremely susceptible to mosaic and its reaction to infection is very severe indeed: plants derived from infected cuttings are severely stunted, with small, misshapen leaves and a proliferation of shoots.

## Selection of Cuttings

Cuttings were taken only from field-grown plants apparently free of mosaic. They were rooted in isolation in coast sandy soil in 15 × 25 cm polythene bags and the shoots carefully inspected at 2-3-day intervals, over a period of 6 weeks, for mosaic symptoms. Any plant with possible symptoms was immediately removed and destroyed. When the population was free of visible signs of mosaic the cuttings were moved to the field.

## Design of Plots

### Rate of Spread Within a Plot

Seven centrally placed, mosaic-infected cuttings of 46106/27 were surrounded by 5 concentric hexagons of a total of 156 mosaic-free cuttings of the same variety. Plants were 1.5 m apart. The plot was planted during the short

rains (9 November 1972), and recordings began on 20 November. Each plant was inspected for cassava mosaic at weekly intervals; infected plants were *not* rogued. This study was concluded 14 months later, in January 1974.

#### Rate of Spread into Mosaic-Free Plots

One hundred mosaic-free plants each of 46106/27 and F279 were planted in 10 alternate rows of 20 plants; plants were 1 m apart with 2 m between the double rows.

One such plot (Plot 1) was sited in open grassland in December 1973; it was approximately 300 m downwind of cassava plots with high incidence of mosaic. Weekly records were taken of mosaic incidence, but, unlike the first experiment, infected plants were immediately rogued. The trial was discontinued in December 1974.

To ensure that results were not attributable to site ecology, a further four similar plots were established during the long rains in April 1975 in four areas of differing ecology. These were Plot 2: on the same site as plot 1, initially with some degree of isolation from other infected cassava. Shortly after initiation of this trial, several plots of cassava in which incidence of mosaic was moderately high were planted within 50 m of Plot 2; Plot 3: surrounded by cashew trees; Plot 4: sheltered from the prevailing winds by citrus, cashew, and coconut trees; Plot 5: on a farm near Mtwapa Research Station, surrounded by widely spaced coconut palm and mixed cultivation.

#### Crop-Loss Assessment Plot

The effect of mosaic on yield has apparently never been assessed or estimated in Kenya, although there are figures for neighbouring Tanzania, and other countries. To estimate the effect of planting infected cuttings on yield of a tolerant and a highly susceptible variety (46106/27 and F279, respectively), a line of 35 plants derived from infected cuttings was planted between two lines of 35 plants derived from mosaic-free cuttings. Rows were 2 m apart with 1.5 m between plants. The trial was established in May 1975 and lifted in February 1976.

The yield of each plant was recorded. Although the design of the plot was not statistical, the results were subjected to an analysis of variance, data being transformed to logs for analysis.

#### Plot Management

Management of plots was kept to a minimum. Fertilizer at the recommended rate for cassava for Coast Province (150 kg/ha sulfate of ammonia, 200 kg/ha double superphosphate, 200 kg/ha muriate of potash) was applied at planting only.

## Results

#### Rate of Spread Within a Plot

Spread from infected to healthy plants was rapid and continued throughout the growing season; at harvest (14 months) 84 of the 156 plants (54%) were infected.

#### Rate of Spread into Mosaic-Free Plots

Spread into mosaic-free plots was very slow and did not build up at any time during the season. The incidence of 46106/27 was: plot 1, 2/100; 2, 0/100; 3, 1/100; 4, 4/100; 5, 2/100; of F279: plot 1, 15/100 (8 of these may have been infected at planting); 2, 0/100; 3, 1/100; 4, 2/100; 5, 5/100.

#### Crop-Loss Assessment Trial

The mean yield per plant (kilograms) for 46106/27 healthy 3.55, diseased 1.19, healthy 4.16; for F279 healthy 3.31, diseased 0.52, healthy 4.03.

## Discussion

Our results suggest that control of mosaic in the field in East African coastal districts is possible by the use of mosaic-free planting material, the roguing of infected plants, and by allowing a reasonable degree of isolation of "clean" plots from infected plots. They also suggest that, under the prevailing climatic conditions, man is a more efficient vector, by his use of infected cuttings, than is whitefly.

Whether these results apply to different climatic regimes, for example where annual rainfall is higher and more evenly distributed, or where the growing period is 18 as opposed to 12 months, remains to be seen. It seems that tolerance in 46106/27 is associated with a less severe reaction of above-ground parts to infection; the drop in yield due to disease is significantly greater (5% level) for F279 than for 46106/27. In the untransformed yield data, loss in yield in 46106/27 was 70%, and in F279 86%; it is thus questionable whether, on

a yield basis alone, 46106/27 can be described as tolerant. Any variety which sustains a 70% loss would in most circumstances be described as highly susceptible.

Our results call for further experimentation in the field, including studies of the vector in ecologically diverse zones. If the concept of

control by relatively simple cultural practices is proved satisfactory, then a reappraisal of breeding objectives might possibly be called for.

Doughty, L. R. *East African Agriculture and Forestry Research Organization Annual Report, 1958*, 48-55.

## Synonymy in Sweet Potato Virus Diseases

J. Mukiibi<sup>1</sup>

The literature pertaining to virus or viruslike diseases of sweet potatoes suggests that there are only two diseases definitely caused by viruses: sweet potato mosaic, with many synonyms, and sweet potato internal cork. The other viruslike diseases are either caused by mycoplasma, mites, or are physiological in nature.

Martyn (1968, 1971) and Smith (1972) listed seven virus diseases of sweet potatoes: (1) feathery mottle; (2) internal cork; (3) mosaic virus A; (4) mosaic virus B; (5) russet crack; (6) yellow dwarf; and (7) witches' broom. My observations suggest that there is no difference between mosaic virus A and B.

Sheffield (1957) distinguishes the two diseases on the basis of severity. Virus A is a mild disease transmitted by *Myzus persicae* and not by white flies. Virus B, a severe disease, is transmitted to sweet potato by the white fly *Bemisia tabaci* and not by aphids or mechanical means. I have frequently transmitted mechanically the severe disease to sweet potato. The aphid *Myzus persicae* is almost invariably associated with the severe disease in the field and has also frequently transmitted the disease from affected to healthy sweet potato vines in the greenhouse. The sweet potato feathery mottle disease as described by Doolittle and Harter (1945) is very similar to the sweet potato mosaic syndrome described by Sheffield (1957).

To help clarify the situation, I have reviewed all the available literature on sweet potato virus and viruslike diseases to establish the identities of the diseases. The results of this extensive literature survey have been summarized in Table 1.

<sup>1</sup>Department of Crop Science, Makerere University, P.O. Box 7062, Kampala, Uganda.

## Discussion

A total of 21 virus or viruslike diseases have been reported from various parts of the world. One of the commonest virus diseases of sweet potatoes is mosaic, with symptoms typical of this group of diseases, it has been observed wherever sweet potatoes are grown extensively (Rosen 1920; Hansford 1944; Adsuar 1955; Yoshii 1960). In East Africa the mosaic syndrome has been referred to as mosaic virus A and mosaic virus B (Sheffield 1957). The syndrome is associated with virus particles of flexuous rods of 761, 767, or 844 nm (Nome 1974; Nome et al. 1974) or 850-900 nm (Hollings et al. 1970).

Descriptions of the diseases referred to as mottle leaf (Strydom and Hyman 1965), leaf spot (Martin 1970), ringspot, vein clearing, and leaf pucker (Loebenstein and Harpaz 1960) are identical with descriptions of foliar symptoms of mosaic. These diseases are also transmitted by aphids or white fly. The diseases referred to as rosette (Noble 1935; Steyaert 1946), curly top and yellow dwarf (Hildebrand 1958a,b) are manifestations of severe symptoms of mosaic and their descriptions are identical with those of sweet potato mosaic virus B. Hence it appears that there are 10 names referring to the same disease, namely mosaic, described by different authors on different varieties in different parts of the world. The disease known as celery mosaic (Welman

a yield basis alone, 46106/27 can be described as tolerant. Any variety which sustains a 70% loss would in most circumstances be described as highly susceptible.

Our results call for further experimentation in the field, including studies of the vector in ecologically diverse zones. If the concept of

control by relatively simple cultural practices is proved satisfactory, then a reappraisal of breeding objectives might possibly be called for.

Doughty, L. R. *East African Agriculture and Forestry Research Organization Annual Report, 1958*, 48-55.

## Synonymy in Sweet Potato Virus Diseases

J. Mukiibi<sup>1</sup>

The literature pertaining to virus or viruslike diseases of sweet potatoes suggests that there are only two diseases definitely caused by viruses: sweet potato mosaic, with many synonyms, and sweet potato internal cork. The other viruslike diseases are either caused by mycoplasma, mites, or are physiological in nature.

Martyn (1968, 1971) and Smith (1972) listed seven virus diseases of sweet potatoes: (1) feathery mottle; (2) internal cork; (3) mosaic virus A; (4) mosaic virus B; (5) russet crack; (6) yellow dwarf; and (7) witches' broom. My observations suggest that there is no difference between mosaic virus A and B.

Sheffield (1957) distinguishes the two diseases on the basis of severity. Virus A is a mild disease transmitted by *Myzus persicae* and not by white flies. Virus B, a severe disease, is transmitted to sweet potato by the white fly *Bemisia tabaci* and not by aphids or mechanical means. I have frequently transmitted mechanically the severe disease to sweet potato. The aphid *Myzus persicae* is almost invariably associated with the severe disease in the field and has also frequently transmitted the disease from affected to healthy sweet potato vines in the greenhouse. The sweet potato feathery mottle disease as described by Doolittle and Harter (1945) is very similar to the sweet potato mosaic syndrome described by Sheffield (1957).

To help clarify the situation, I have reviewed all the available literature on sweet potato virus and viruslike diseases to establish the identities of the diseases. The results of this extensive literature survey have been summarized in Table 1.

<sup>1</sup>Department of Crop Science, Makerere University, P.O. Box 7062, Kampala, Uganda.

## Discussion

A total of 21 virus or viruslike diseases have been reported from various parts of the world. One of the commonest virus diseases of sweet potatoes is mosaic, with symptoms typical of this group of diseases, it has been observed wherever sweet potatoes are grown extensively (Rosen 1920; Hansford 1944; Adsuar 1955; Yoshii 1960). In East Africa the mosaic syndrome has been referred to as mosaic virus A and mosaic virus B (Sheffield 1957). The syndrome is associated with virus particles of flexuous rods of 761, 767, or 844 nm (Nome 1974; Nome et al. 1974) or 850-900 nm (Hollings et al. 1970).

Descriptions of the diseases referred to as mottle leaf (Strydom and Hyman 1965), leaf spot (Martin 1970), ringspot, vein clearing, and leaf pucker (Loebenstein and Harpaz 1960) are identical with descriptions of foliar symptoms of mosaic. These diseases are also transmitted by aphids or white fly. The diseases referred to as rosette (Noble 1935; Steyaert 1946), curly top and yellow dwarf (Hildebrand 1958a,b) are manifestations of severe symptoms of mosaic and their descriptions are identical with those of sweet potato mosaic virus B. Hence it appears that there are 10 names referring to the same disease, namely mosaic, described by different authors on different varieties in different parts of the world. The disease known as celery mosaic (Welman

Table 1. Notes on virus and viruslike diseases of sweet potato.

Disease	Symptoms and modifying factors	Transmission	Causal agent	Distribution	Importance	Control
Mosaic	Vein clearing, vein banding, leaf distortion, small leaves sometimes wrinkled; short internodes and rosetting; may cause necrosis in tubers; symptom expression varies with temperature and cultivar	<i>Myzus persicae</i> , <i>Bemisia tabaci</i> . Grafting, mechanically, vegetative propagation. Not seed transmitted.	Virus(es) several strains. Flexuous rods 761, 767 or 850-890 nm. Serological characteristics not reported	USA, Puerto Rico Venezuela, Uganda Kenya, Tanzania, Malawi South Africa, Zaire Nigeria, ? Ghana ?Australia	Very severe in East and Central Africa and in Southern USA as well as South Africa and ? Australia	Virus-free planting material; heat therapy possible at 110°F; control with resistant cultivars possible; spraying against vectors did not reduce incidence in Uganda
Celery mosaic	Same as above; apparently a disease of celery transferred artificially to sweet potatoes	<i>Aphis gossypii</i>	Virus presumed	Cuba, Florida (USA)	Not specified	Not specified
Mottle leaf	Yellow spots on foliage	White fly: <i>Trialeurodes abutilonea</i>	Virus presumed	USA, South Africa	Severe in combination with "yellow dwarf" in South Africa	Not specified
Leaf spot	Small yellow spots almost like above but smaller	Not specified	Virus presumed	USA	Not specified	Not specified
Ring spot	Conspicuous chlorotic spots plus stunting; symptom expression varies between cultivars	<i>Myzus persicae</i> but not <i>Bemisia tabaci</i> ; also transmitted mechanically	Virus particles of unspecified size; some particles similar to feathery mottle virus but differ from cucumber mosaic	USA, Israel	Not specified	Not specified
Vein clearing	Similar to mosaic especially as found in East Africa; symptoms masked by heat	Grafting; <i>Bemisia tabaci</i> but not mechanically	Virus presumed	USA, Ghana, Israel	Very severe losses in Israel and Ghana	Not specified
Leaf pucker	Leaf mottle, vein clearing, leaf wrinkling, folding and reduction in size; develops better in cool weather	Grafting but not aphids nor whitefly	Virus presumed	Israel, Philippines	Minor loss	Not specified
Rosette	Stunting and proliferation of branches from leaf axils	Not specified	Virus suspected	Australia, Zaire	Destructive in both areas	Not specified

Curly top	As above	Not specified	Virus suspected	Australia	Destructive	Not specified
Feathery mottle	Random bright yellow spots or streaks; vein clearing and banding; leaf yellowing, distortion, stunting; some aspects similar to East African "virus A"; also shown to consist of three components: yellow dwarf, internal cork and leaf spot; symptoms more apparent in shade; cultivars react differently	Grafting; mechanical; <i>Myzus persicae</i> (non-persistent), <i>Aphis gossypii</i> , <i>Aphis apii</i> , <i>Microsiphum solanifolii</i> , <i>T. abutilonea</i>	Virus; flexuous rods of 800-844 nm; sub-strains suspected	USA, Japan New Guinea, ? Ghana	Potentially destructive	Control with resistant varieties possible
Russet crack	Leaf symptoms same as mosaic and feathery mottle; roots with superficial longitudinal cracks which may become corky; symptoms masked by temperature; cultivars react differently	Grafting; <i>Myzus persicae</i> and <i>A. gossypii</i>	Virus; flexuous rods of 800 and 876 nm seen; cross protection with feathery mottle	USA, Tonga Australia, New Zealand	Reduces market quality and yield	Not specified
Internal cork	Dark brown to black necrotic spots in tuber flesh starting as collapsed cells; development of phellogen around spots progressively producing cork; also sunken corky lesions on surface of tuber; cork may develop following mechanical injury; on foliage vein clearing, banding, green mottle, purple spots, bronzing, and necrotic streaks; three strains: severe, moderate, and mild. Heat enhances symptoms; warmer soil increases severity	Mechanical; <i>Myzus persicae</i> , <i>Aphis gossypii</i> , <i>Macrosiphum solanifolii</i> , grafting; vegetative propagation	Virus; viral RNA detected and polyhedral particles of 450-475A° seen	USA, Tonga New Zealand, ? Uganda	Yield unaffected but market value drastically reduced; flavour not affected; greatest effect in storage at high temperature	Spraying against vectors; storage at 55-60°F; resistant lines developed; tissue culture potential
Mottle necrosis	As for internal cork; apparently renamed internal cork	Not specified	<i>Pythium</i> sp., boron deficiency	USA	Severely reduces market value	Application of boron failed to control disease

Table 1. Notes on virus and viruslike diseases of sweet potato (concluded).

Disease	Symptoms and modifying factors	Transmission	Causal agent	Distribution	Importance	Control
Internal root necrosis	Brown necrotic streaks in tuber; not affected by storage at 75°F	Grafting failed	Physiological	New Zealand	Not specified	Not specified
Little leaf	Small narrow distorted yellow leaves; stunting; some necrotic streaks; rosette effect similar to Ishukubyo	Grafting; <i>Halticus tibialis</i> . Believed soil-borne	Mycoplasma-like bodies seen; virus suspected	Tonga, New Zealand Papua New Guinea	Severe in Papua New Guinea	Tetracycline; heat therapy 45-65°F; resistant clones; roguing ineffective
Witches' broom	As for little leaf	Grafting <i>Nesophrasyna ryukyuensis</i> ; not by aphids, other leaf hoppers or seed	? Virus; mycoplasma-like bodies seen 200-250 um in phloem	Japan, Taiwan, Korea Java, Tonga, New Zealand	Very severe on Ryukyu Islands	Tetracycline; terramycin, hot water 45-60°F; resistant clones developed
Dwarf or ishukubyo	Dwarfing; proliferation of shoot from axils; small yellow leaves; stem produces little or no latex	Not specified	? virus; disease apparently same as Witches' broom	Ryukyu, Japan	Severe on Ryukyu Islands	Not specified, but see witches' broom
Yellow dwarf	Stunting, reduced leaf size and similar to East African mosaic disease "virus B"	Grafting; <i>Trialeurodes abutilonea</i> adults only	Virus suspected	USA, Israel New Zealand, South Africa	Very severe in parts of USA	Heat therapy, water at 38°C
Hard-core	Hard regions of tuber, inedible after cooking; condition increases with cold, reduces with heat	Not specified	Conflicting views: virus particles seen, flexuous rods 700 nm in roots and leaves; physiological	USA	Reduce cooking quality	Not specified
Erinose	Little to extreme hairiness of vines and leaves, leaf size reduced, plants stunted, necrosis of terminal buds; swelling of affected vines; varies with weather	Spider mite <i>Aceria</i> sp. Not transmitted by grafting	Not known with certainty. Mites suspected more than virus.	Uganda, Kenya Tanzania, Zaire and Rwanda	Affected vines produce few tubers.	Spraying with azobenzene
Bitter root	Roots bitter to taste either raw or cooked. Sometimes there are swellings on bitter roots possibly induced by insects. No external leaf symptoms.	Not known	Not known	Teso, Lango, West Nile and North Kigezi districts of Uganda.	Affected tubers too bitter for eating. Yield apparently not affected	Not known

1934, 1935) is apparently a disease of celery which was transmitted artificially to sweet potato.

The other common disease is feathery mottle (Doolittle and Harter 1945). A comparison of the photographs showing the symptoms of this disease (Doolittle and Harter 1945) and Sheffield's (1957) photographs of the mosaic diseases of sweet potatoes in East Africa, shows clearly that the symptoms of the two diseases are identical. The virus particles identified in both diseases also appear very similar (Nome et al. 1974; Hollings et al. 1970) and both diseases are masked by high temperature. Further, Alconero (1971) and Nome et al. (1974) have shown that the feathery mottle disease is the same as russet crack. Hence it appears that the mosaic diseases mentioned earlier, feathery mottle and russet crack, are one and the same disease, or are very closely related manifestations of a mosaic syndrome.

The internal cork virus disease, however, appears to be a distinct disease unrelated to mosaics both in symptom expression and etiology. The most characteristic symptom of the disease is the development of cork in the tubers (Nusbaum 1946a,b) which is associated with polyhedral virus particles (Salama et al. 1966). A disease which in early literature (Harter 1925; Harter and Whitney 1929) was described as mottle necrosis was apparently the same and was renamed "internal cork virus" disease when its etiology became known.

Little leaf (van Velsen 1967), witches' broom (Murayama 1966), and ishuku-byo (Summers 1951) are all transmitted by leaf hoppers and are associated with mycoplasma-like bodies (Lawson et al. 1970; Kahn et al. 1972). They can be cured with antibiotics (So 1973) and are therefore not virus diseases.

Hardcore seems to be a disease of uncertain etiology. Daines et al. (1974) have conducted experiments on it and concluded that it was related to chilling during the process of curing the tubers. When the tubers were cured at a temperature of 27 °C the disease did not develop. But Harmond et al. (1974) noticed flexuous virus rod particles 700 nm long in roots and leaves affected by hardcore. These workers do not specify whether or not the material they used contained a latent virus infection.

Another disease affecting tubers is internal root necrosis (Nielsen and Harrow 1966). It causes lesions of a lighter colour than internal

cork, is not affected by temperature, and is not graft transmissible. Therefore it is probably a physiological condition.

Erinose of sweet potatoes (Sheffield 1954), a common disease in East Africa, causes extreme hairiness to vines and leaves of sweet potatoes and may lead to heavy losses in yield. It is associated with spider mites (*Aceria* sp.), and Sheffield failed to transmit it by grafting. Affected vines recovered from the disease when they were fumigated with azobenzene. Hence available evidence suggests that the disease is caused by mites *sensu stricto*.

There is a disease in Uganda known as "bitter root" which makes the tubers unpalatable. The disease has not been investigated sufficiently and its etiology is therefore unknown.

## Conclusion

From the evidence, it appears that there are two distinct virus diseases of sweet potatoes: (1) sweet potato mosaic covering all diseases with mosaic symptoms as well as feathery mottle and russet crack; these diseases are associated with virus particles consisting of flexuous rods 760–900 nm; and (2) internal cork characterized by tubers containing necrotic regions surrounded by phellem. The foliar symptoms may be of a mosaic type but the disease is associated with polyhedral virus particles. There is no conclusive evidence that hardcore disease is caused by either a virus or a physiological disorder.

Other viruslike diseases are caused by: mycoplasma-like bodies; mites; physiological disorders; genetics (as in the case of bitter root).

Information on sweet potato virus diseases has been derived largely from symptomatology of sweet potato and other hosts, and from the mode of transmission. Only to a limited extent has this knowledge been based on electron-microscopy or serology. There is a need for more electronmicroscopic and serological studies of sweet potato viruses to verify the identity of each and to better understand the relationships between the diseases.

Adsuar, J. *A mosaic disease of sweet potato Ipomea batatas in Puerto Rico*. Journal of the Agricultural University of Puerto Rico, 39, 1955, 49–50.

Alconero, R. *Sweet potato virus infections in Puerto Rico*. Plant Disease Reporter, 55, 1971, 902–906.

Daines, R. H. et al. *Relationship of chilling to*

- development of hardcore in sweet potatoes.* Phytopathology, 64, 1974, 1459-1462.
- Doolittle, S. P., and Harter, L. L. *A graft transmissible virus of sweet potato.* Phytopathology, 35, 1945, 695-704.
- Hansford, C. G. *A probable virus disease of sweet potato.* East African Agricultural Journal, 10, 1944, 126-127.
- Harmond, D. F. et al. *The association of cellular inclusions and virus like particles with "hardcore" of fleshy sweet potato roots.* Plant Disease Reporter, 58, 1974, 17-20.
- Harter, L. L. *Mottle necrosis of sweet potatoes.* Phytopathology, 15, 1925, 45.
- Harter, L. L., and Whitney, W. A. *Masking of sweet potato mosaic.* Phytopathology, 19, 1929, 933-942.
- Hildebrand, E. M. *Two syndromes caused by sweet potato viruses.* Science, 128, 1958a, 203-204.
- Natural transmission of sweet potato mottle virus.* Abs. in Phytopathology, 48, 1958b, 462.
- Hollings, M. et al. *Report of the Glass House Crops Research Institute (1970), 1970.*
- Kahn, R. P. et al. *Sweet potato little leaf (witches' broom) associated with a mycoplasma like organism.* Phytopathology, 62, 1972, 903-909.
- Lawson, R. H. et al. *The association of mycoplasma like bodies with sweet potato little leaf (witches' broom) disease.* Abs. in Phytopathology, 60, 1970, 1016.
- Loebenstein, G., and Harpaz, I. *Virus disease of sweet potatoes in Israel.* Phytopathology, 50, 1960, 100-104.
- Martin, W. J. *The reproduction of russet crack in Jersey orange sweet potato by grafting on plants affected with either sweet potato leaf spot or internal cork.* Abs. in Phytopathology, 60, 1970, 1302.
- Murayama, D. *On the witches' broom diseases of sweet potato and leguminous plants in the Ryukyu Islands.* Memoirs of the Faculty of Agriculture Hokkaido University, 6, 1966, 81-103.
- Martyn, B. E. *Plant virus names.* Phytopathological Paper No. 9., C.M.I., 1968, 204.
- Plant virus names. Supplement No. 1.* C.M.I., 1971, 41.
- Nielsen, L. W., and Harrow, K. M. *Observation on an internal root necrosis of a New Zealand sweet potato.* Plant Disease Reporter, 50, 1966, 703-771.
- Noble, R. J. *Australia: Notes on plant diseases recorded in New South Wales for the year ending 30th June 1934.* International Bulletin of Plant Protection, 9, 1935, 2-5.
- Nome, S. F. *Sweet potato vein mosaic virus in Argentina.* Phytopathology, 2, 1974, 44-54.
- Nome, S. F. et al. *Comparison of virus particles and intercellular inclusions associated with vein mosaic, feathery mottle and russet crack diseases of sweet potatoes.* Phytopathology, 2, 1974, 169-178.
- Nusbaum, C. J. *Internal cork, a new disease of sweet potato of unidentified cause.* Phytopathology, 26, 1946a, 18-32.
- Internal brown spot, a boron deficiency disease of sweet potatoes.* Phytopathology, 26, 1946b, 164-167.
- Rosen, H. R. *The mosaic disease of sweet potatoes.* Arkansas Agricultural Experiment Station Bulletin No. 167, 1920.
- Salama, F. M., Lyman, C. M., and Whitehouse, V. G. *Isolation of the internal cork virus from sweet potato leaves having the purple ring structure by use of different filtration.* Phytopathology, 2, 1966, 89-95.
- Sheffield, F. M. L. *Erinose in sweet potatoes.* Empire Journal of Experimental Agriculture, 22, 1954, 97-100.
- Virus diseases of sweet potato in East Africa. 1. Identification of the viruses and their vectors.* Phytopathology, 47, 1957, 582-590.
- Smith, K. M. *A text book of plant virus diseases.* 3rd Edition, Longmans, 1972, 498-499.
- So, I. Y. *Studies on the mycoplasmic witches' broom of sweet potato in Korea, (1) Symptoms and pathogens.* Korean Journal of Microbiology, 11, 1973, 19-30.
- Steyaert, R. L. *Plant protection in the Belgian Congo.* Science Monitor, 58, 1946, 268-280.
- Strydom, E., and Hyman, L. G. R. *The production and marketing of sweet potatoes.* Bulletin of the Department of Agriculture, Technical Services South Africa No. 382, 1965, 43 p.
- Summers, E. M. *"Ishuku-byo" (dwarf) of sweet potato in the Ryukyu Island.* Plant Disease Reporter, 35, 1951, 266-267.
- Van Velsen, R. J. *Little leaf, a virus disease of Ipomoea batatas in Papua and New Guinea.* Papua New Guinea Agricultural Journal, 18, 1967, 126-128.
- Welman, F. L. *Infection of Zea mays and various other Gramineae by the celery virus in Florida.* Phytopathology, 24, 1934, 1035-1037.
- The host range of the Southern Celery mosaic virus.* Phytopathology, 25, 1935, 376-404.
- Yoshii, H. *On mosaic disease of sweet potato.* Annals of the Phytopathological Society of Japan, 25, 1960, 71-74.

## Effect of Mosaic on the Yield of Sweet Potatoes in Uganda

J. Mukiibi<sup>1</sup>

The sweet potato mosaic virus disease caused a 57% reduction in yield, both in terms of the weight and the number of root tubers produced by the sweet potato variety Kyebandula. The sample plots were grown at the Makerere University farm in Uganda.

Sweet potato mosaic was first recorded in Uganda by Hansford (1944a) who noted that it was very severe in some areas. Later he published an account of his observations (Hansford 1944b) on a trial of sweet potatoes at Kawanda Research Station in which he noted that the effect of the disease was probably high judging by the appearance of affected plots. However he gave no data on the effect of the disease on yield.

Sheffield (1953) surveyed the incidence of the disease in Kenya, Uganda, Tanzania, Rwanda, and Zaïre. While on this survey she was informed that the disease was probably responsible for the degeneration of sweet potato varieties on peasant farms. This view was also expressed by Macdonald (1965) who thought that the rapid turnover of sweet potato varieties in Uganda was probably due to virus diseases.

Sheffield (1953) also learned that on a farm in Eastern Zaïre, where sweet potatoes were grown to feed mine workers, yields had declined from 30 to 4 metric tons per hectare. The growing of sweet potatoes on that farm was later abandoned, apparently because of virus diseases.

Yet, despite these observations, some extension workers feel that sweet potato virus diseases did not cause much loss in Uganda. An experiment was therefore conducted at the Makerere University farm to establish the loss likely to result from sweet potato virus infections.

### Materials and Methods

The sweet potato variety Kyebandula was planted on ridges 90 cm apart and 30 cm between plants. The experiment consisted of five treatments as follows: plots were planted (a) with all vines apparently healthy, (b) 25%,

(c) 50%, (d) 75% of the vines infected by mosaic, and (e) plots planted with all infected vines. The vines chosen for planting were 20–30 cm long with 4–5 fully expanded leaves. All the leaves on infected vines had clear symptoms of mosaic.

The experiment consisted of four replicates and the plots were assigned within replicates in a latin square design. The plots consisted of five rows 4.5 m long. The planting of the vines was performed as follows: to obtain a proportion of 25% infected plants, one diseased plant was planted for every three healthy plants, for 50% every alternate plant was diseased, for 75% three infected plants were planted, for every one healthy plant. The vines were buried about 10 cm deep.

The potatoes were harvested 150 days after planting. During this period there was some secondary spread by the virus ranging from 11% for all healthy and 25% diseased, 16% for the 50% diseased, and 23% for 75% diseased plantings.

### Results and Discussion

The results are summarized in Table 1, which shows that the average yield per plot was, as expected, lowest in those planted with only infected vines and highest in plots planted with only healthy vines. The disease caused a reduction in weight yield and number of tubers of 57.1 and 57.3% respectively, in the totally affected vines. The yield was progressively reduced as the proportion of the diseased vines increased in the planting material.

The fact that the percentage loss is about equal both for weight of potatoes and number of potatoes per plot indicates that the effect of the disease is to reduce the number of roots which form tubers.

At the time of harvest, the incidence of the disease had reached 11% in plots planted with healthy vines alone. This level of disease must have depressed the yield in those plots. This

<sup>1</sup>Department of Crop Science, Makerere University, P.O. Box 7062, Kampala, Uganda.

Table 1. Effect of planting various proportions of healthy and mosaic-infected sweet potato vines on the yield of sweet potatoes.

% of mosaic vines per plot	Average weight of potatoes per plot (kg)	Average number of tubers/plot	% loss in weight yield	% loss in tuber number
0	20.6	141.4	—	—
25	18.6	128.7	9.8	11.7
50	16.2	110.3	21.3	22.0
75	13.9	89.5	47.3	36.7
100	8.9	60.4	57.1	57.3

means that the true loss due to the disease was probably higher than 57%, perhaps about 60%.

Hansford, C. G. *Report by plant pathologist*. In Annual report for July 1943–June 1944, 1944a, 5–7.

*A probable virus disease of sweet potatoes.*

East African Agricultural Journal, 10, 1944b, 126–127.

Macdonald, A. S. *Variation in open pollinated sweet potato seedlings in Buganda, East Africa*. East African Agriculture and Forestry Journal, 31, 1965, 183–188.

Sheffield, F. M. L. *Virus diseases of sweet potato in parts of Africa*. Empire Journal of Experimental Agriculture, 21, 1953, 184–190.

## Incidence, Symptomatology, and Transmission of a Yam Virus in Nigeria

E. R. Terry<sup>1</sup>

*A Dioscorea* spp. virus disease incidence was highest in field planting in Ibadan on *D. rotundata* Ihobia variety. Field symptoms included green vein-banding, shoestring, and distortion. The virus was transmitted mechanically, and by nymphs and winged adults of the cotton aphid *Aphis gossypii* to seedlings of *D. rotundata*. Test plants in mechanical and vector transmission studies exhibited mainly green vein-banding. The role of *A. gossypii* in field spread of this disease is discussed.

Virus diseases of *Dioscorea* spp. have been reported mainly from West Africa and the Caribbean, but may probably occur in all yam-growing areas of the world (Coursey 1967).

In Nigeria, reports by Chant (1957) and Robertson (1961) reported localized incidences of a virus disease of *D. alata*, *cayenensis*, and *rotundata*. Infected plants appeared stunted, with proliferation of lateral buds giving the plant a bushy form. Foliar symptoms consisted of mottling, vein-clearing, and sometimes lanceolation and distortion (Robertson 1961).

Robertson's (1961) attempts to transmit the agent by mechanical inoculation were unsuccessful and he suggested that the disease was

caused by a physiological imbalance in the plant.

Some preliminary results on the incidence, symptomatology, and transmission of a *Dioscorea* spp. virus disease in Nigeria are presented.

### Disease Incidence

Tubers harvested in 1974 from six varieties of *D. rotundata* (Laoko, Boki, Ihobia, Okumado, Iwo, and Umudike) were planted at IITA in April–May 1975. Virus disease incidence was highest in Ihobia, with 51.9, 8.1 and 2.8% of the plants manifesting green vein-banding, shoestring, and distortion respectively. There was considerable variation in varietal susceptibility to the virus but it appeared that all varieties were susceptible (Table 1).

<sup>1</sup>International Institute of Tropical Agriculture, P.M.B. 5320, Ibadan, Nigeria.

Table 1. Effect of planting various proportions of healthy and mosaic-infected sweet potato vines on the yield of sweet potatoes.

% of mosaic vines per plot	Average weight of potatoes per plot (kg)	Average number of tubers/plot	% loss in weight yield	% loss in tuber number
0	20.6	141.4	—	—
25	18.6	128.7	9.8	11.7
50	16.2	110.3	21.3	22.0
75	13.9	89.5	47.3	36.7
100	8.9	60.4	57.1	57.3

means that the true loss due to the disease was probably higher than 57%, perhaps about 60%.

Hansford, C. G. *Report by plant pathologist*. In Annual report for July 1943–June 1944, 1944a, 5–7.

*A probable virus disease of sweet potatoes.*

East African Agricultural Journal, 10, 1944b, 126–127.

Macdonald, A. S. *Variation in open pollinated sweet potato seedlings in Buganda, East Africa*. East African Agriculture and Forestry Journal, 31, 1965, 183–188.

Sheffield, F. M. L. *Virus diseases of sweet potato in parts of Africa*. Empire Journal of Experimental Agriculture, 21, 1953, 184–190.

## Incidence, Symptomatology, and Transmission of a Yam Virus in Nigeria

E. R. Terry<sup>1</sup>

*A Dioscorea* spp. virus disease incidence was highest in field planting in Ibadan on *D. rotundata* Ihobia variety. Field symptoms included green vein-banding, shoestring, and distortion. The virus was transmitted mechanically, and by nymphs and winged adults of the cotton aphid *Aphis gossypii* to seedlings of *D. rotundata*. Test plants in mechanical and vector transmission studies exhibited mainly green vein-banding. The role of *A. gossypii* in field spread of this disease is discussed.

Virus diseases of *Dioscorea* spp. have been reported mainly from West Africa and the Caribbean, but may probably occur in all yam-growing areas of the world (Coursey 1967).

In Nigeria, reports by Chant (1957) and Robertson (1961) reported localized incidences of a virus disease of *D. alata*, *cayenensis*, and *rotundata*. Infected plants appeared stunted, with proliferation of lateral buds giving the plant a bushy form. Foliar symptoms consisted of mottling, vein-clearing, and sometimes lanceolation and distortion (Robertson 1961).

Robertson's (1961) attempts to transmit the agent by mechanical inoculation were unsuccessful and he suggested that the disease was

caused by a physiological imbalance in the plant.

Some preliminary results on the incidence, symptomatology, and transmission of a *Dioscorea* spp. virus disease in Nigeria are presented.

### Disease Incidence

Tubers harvested in 1974 from six varieties of *D. rotundata* (Laoko, Boki, Ihobia, Okumado, Iwo, and Umudike) were planted at IITA in April–May 1975. Virus disease incidence was highest in Ihobia, with 51.9, 8.1 and 2.8% of the plants manifesting green vein-banding, shoestring, and distortion respectively. There was considerable variation in varietal susceptibility to the virus but it appeared that all varieties were susceptible (Table 1).

<sup>1</sup>International Institute of Tropical Agriculture, P.M.B. 5320, Ibadan, Nigeria.

Table 1. Incidence of yam virus disease on vegetatively propagated *Dioscorea rotundata* plants (IITA Ibadan 1975).

Families	Total No.	GVB		Shoestring		Distortion and stunting	
		No.	%	No.	%	No.	%
Laoko	20	1	5	—	—	—	—
Boki	549	171	31.1	13	2.3	2	0.36
Ihobia	839	436	51.9	68	8.1	24	2.80
Okunmodo	13	—	—	1	7.6	—	—
Umudike	936	95	9.8	43	4.4	7	0.72
Iwo	1154	278	24.0	5	0.43	6	0.51

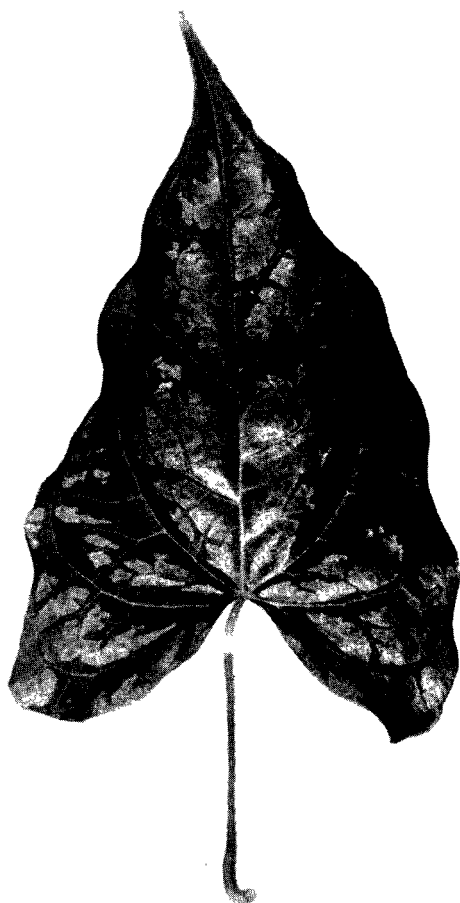
Fig. 1. Green vein-banding on *Dioscorea rotundata*.

### Symptomatology

The most consistent symptoms of virus infection during the growing season were: (1) green vein-banding, which consisted of dark-green leaf veins against light-green interveinal

areas (Fig. 1); (2) shoestring and bushiness, consisting of narrow lanceolate leaves and proliferation of lateral shoots giving the plant a bushy appearance; (3) distortion, which consisted of puckering, rugosity, and curling of leaf edges; (4) leaf mottling, consisting of irregular patches of dark-green and chlorotic areas; (5) stunting of the entire plant.

Infected plants may manifest all of the above symptom combinations or any one of them exclusively. Different symptoms appeared at different times during the growth cycle of infected plants.

### Mechanical Transmission

#### Source of Inoculum

Crude sap for mechanical inoculation was prepared from infected plants manifesting exclusively one of the following symptoms: leaf mottling (MOT), green vein-banding (GVB), shoestring (SS), or green vein-banding together with distortion (GVB/Dist). Inoculum from plants exhibiting each symptom type was prepared by macerating 5 g of infected leaves in 1 ml buffer solution containing 0.05 M, pH 7.0 phosphate buffer and 0.01 M cysteine hydrochloride (Ruppel et al. 1966). Activated charcoal was added to the inoculum during maceration.

#### Test Plants

Seeds obtained from female Boki plants were germinated in petri dishes. Seedlings were later transplanted in peat pots and grown under fluorescent light to the 3-leaf stage before transplanting in sterilized soil in pots.

#### Inoculation

Test seedlings were inoculated at the 3-leaf stage by rubbing carborundum-dusted leaves

Table 2. Mechanical transmission of yam virus to *D. rotundata* Boki variety (IITA Ibadan 1975).

Virus source	No. of tested plants	No. of infected plants	Symptom expression
<i>D. rotundata</i> (GVB)	31	26	GVB
	31	2	GVB/SS
<i>D. rotundata</i> (MOT)	20	20	GVB
<i>D. rotundata</i> (SS)	23	15	GVB
<i>D. rotundata</i> (GVB/DIST)	20	18	GVB
Check	47	0	—

with cheese-cloth pads dipped in the crude sap preparation. Untreated checks were rubbed with the buffer solution alone. All plants were grown in an insect-proof greenhouse with a mean temperature of 27.8–34.5 °C, a mean relative humidity of 67–89%, and mean solar radiation of 57.4–89.2 cal/g cm<sup>2</sup>/day.

### Insect Transmission

The cotton aphid, *Aphis gossypii* (Glov.) (identified, courtesy of the Commonwealth Institute of Entomology, London, England) was frequently observed infesting *D. rotundata* plants at IITA, and more often, a common weed (*Commelina benghalensis*) growing among yam plants. A preliminary test to identify biological factors responsible for the rapid spread of the disease was conducted by protecting 25 disease-free *D. rotundata* seedlings in the field with a 40-mesh screened cage. An equal number of seedlings from the same source were planted unprotected in an adjacent plot. Characteristic green vein-banding and leaf mottling symptoms were observed on the unprotected seedlings which were infested with *A. gossypii* 10 days after planting, whereas 60 days after caging, all the seedlings protected from insect infestation remained symptom-free.

Nymphs and adults of *A. gossypii* were reared on *C. benghalensis* in cages. They were given a 4-h access feeding on infected *D. rotundata* plants and then transferred to disease-free seedlings for a 4-h inoculation feed. An equal number of virus-free aphids were transferred to another set of seedlings from the same source and allowed to feed for the same period. At the end of the feeding period they were removed by a fine camel-hair brush.

To determine the minimum time required for inoculation by aphids after access feeding, a

serial transfer study was conducted. Inoculation feeding periods were varied from 1 min to 4 h (with 30 min intervals) with the same aphid, on a series of test plants.

### Results and Discussion

Mechanical transmission studies indicate that irrespective of the inoculum source, 97% of the infected test plants manifested only the green vein-banding symptoms (Table 2). However, two of the infected plants exhibited shoestring and bushy-form symptoms 77 days after inoculation. The interval between inoculation and green vein-banding symptom expression ranged from 7 to 13 days. All of the untreated plants were symptom-free after 90 days. Attempts to mechanically transmit the virus to an unidentified wild species, and also to *D. preussii* and *D. data*, were unsuccessful.

Vector transmission studies indicate that *A. gossypii* is a very efficient vector of the virus (Table 3). All infected plants developed the characteristic green vein-banding symptom between 7 to 15 days. In the serial transmission tests, only plants exposed to 1-min inoculation feeding developed typical symptoms. The remaining plants in the inoculation series were symptom-free. Both nymphs and adults of *A. gossypii* were capable of transmitting the virus.

In the mechanical inoculation tests, all infected test plants manifested the characteristic green vein-banding between 7 and 13 days. On a few plants, however, leaf mottling preceded the green vein-banding, and on two plants lateral shoot proliferation and shoestring were observed after 77 days.

Under field conditions, leaf mottling is normally followed by green vein-banding, suggesting that the former is an early manifestation of the disease but transient in nature. The occurrence of lateral shoot proliferation and

Table 3. Vector transmission of yam virus to *D. rotundata* Boki variety (IITA Ibadan 1975).

Virus source	No. of tested plants	Inoculation period (min)	No. of infected plants	Symptom expression
<i>D. rotundata</i> (GVB)	37	240	17	GVB
<i>D. rotundata</i> (GVB)	27	1	7	GVB
Check	20	240	0	—
Check	18	1	0	—

shoestring after a long incubation period cannot be readily explained.

The relationships between the virus, varietal reaction, symptom expression, and incubation period with particular reference to the characteristic shoestring symptoms are being further investigated.

Transmission attempts with a green-banding virus of *Dioscorea* spp. in Puerto Rico (Ruppel et al. 1966) resulted in an extremely low (20%) transmission to *D. composita* and *D. floribunda*. Transmission percentages in this study to *D. rotundata*, however, were as high as 80%. It is not known whether the Puerto Rico virus is similar to that in Nigeria. Investigations to determine the properties of the Nigerian disease agent are in progress.

Rearing of *A. gossypii* on caged *C. benghalensis* was relatively easy. Attempts have not been made, however, to rear them on caged *D. rotundata*. The ease with which *A. gossypii* transmits the virus, and the level of field infestation of yam by this aphid indicate that it

may play a role in the field spread of the disease. Transmission of the virus by nymphs after 1 min inoculation feeding, after which they appeared to lose infectivity in subsequent serial transfer, suggests a nonpersistent relationship between the virus and the aphid.

Investigations are in progress to identify other yam-infesting insects that may also be vectors of the virus.

Chant, S. R. *Annual Report, Federal Department of Agricultural Research, Nigeria, 1954/55*. 1957.

Coursey, D. G. *Yams*. Longmans Green & Co. Ltd., London, 1967, 230 p.

Robertson, D. G. *Annual Report, Federal Department of Agricultural Research, Nigeria, 1959/60*. 1961.

*Annual Report Federal Department of Agricultural Research, Nigeria, 1962/63*. 1964.

Ruppel, E. G., Delpin, H., and Martin, F. W. *Preliminary studies of a virus disease of sapogenin-producing Dioscorea species in Puerto Rico*. J. Agric. Univ. Puerto Rico, 50, 1966, 151-157.

## Lipid Metabolism in Mosaic-Infected Cassava

C. A. Ninan, Susan Abraham, L. Sandhyavathi Bai,  
P. N. Chandrasekharan Nair, and Philomena Kuriachen<sup>1</sup>

Two varieties of cassava, M4 and H.165 (accession numbers M.67-01 and M.72-10), were selected for studies on the lipid metabolism in cassava mosaic-infected plants. There was a decrease in total lipids, phospholipids, and triglycerides in the leaves and petioles of both infected varieties.

Diseases exert a profound influence on the metabolism of the host plant. Diener (1960) reported a high concentration of asparagine and glutamine in virus-infected cherry and

peach leaves. Accumulation of asparagine was also reported in maize plants infected by maize rough dwarf virus (Harpaz and Applebaum 1961). Previous studies have shown that in mosaic-infected cassava, carbohydrate and nitrogen metabolism are altered due to the virus infection (Beck and Chant 1958; Ala-

<sup>1</sup>Department of Botany, University of Kerala, Trivandrum, India.

Table 3. Vector transmission of yam virus to *D. rotundata* Boki variety (IITA Ibadan 1975).

Virus source	No. of tested plants	Inoculation period (min)	No. of infected plants	Symptom expression
<i>D. rotundata</i> (GVB)	37	240	17	GVB
<i>D. rotundata</i> (GVB)	27	1	7	GVB
Check	20	240	0	—
Check	18	1	0	—

shoestring after a long incubation period cannot be readily explained.

The relationships between the virus, varietal reaction, symptom expression, and incubation period with particular reference to the characteristic shoestring symptoms are being further investigated.

Transmission attempts with a green-banding virus of *Dioscorea* spp. in Puerto Rico (Ruppel et al. 1966) resulted in an extremely low (20%) transmission to *D. composita* and *D. floribunda*. Transmission percentages in this study to *D. rotundata*, however, were as high as 80%. It is not known whether the Puerto Rico virus is similar to that in Nigeria. Investigations to determine the properties of the Nigerian disease agent are in progress.

Rearing of *A. gossypii* on caged *C. benghalensis* was relatively easy. Attempts have not been made, however, to rear them on caged *D. rotundata*. The ease with which *A. gossypii* transmits the virus, and the level of field infestation of yam by this aphid indicate that it

may play a role in the field spread of the disease. Transmission of the virus by nymphs after 1 min inoculation feeding, after which they appeared to lose infectivity in subsequent serial transfer, suggests a nonpersistent relationship between the virus and the aphid.

Investigations are in progress to identify other yam-infesting insects that may also be vectors of the virus.

Chant, S. R. *Annual Report, Federal Department of Agricultural Research, Nigeria, 1954/55*. 1957.

Coursey, D. G. *Yams*. Longmans Green & Co. Ltd., London, 1967, 230 p.

Robertson, D. G. *Annual Report, Federal Department of Agricultural Research, Nigeria, 1959/60*. 1961.

*Annual Report Federal Department of Agricultural Research, Nigeria, 1962/63*. 1964.

Ruppel, E. G., Delpin, H., and Martin, F. W. *Preliminary studies of a virus disease of sapogenin-producing Dioscorea species in Puerto Rico*. J. Agric. Univ. Puerto Rico, 50, 1966, 151-157.

## Lipid Metabolism in Mosaic-Infected Cassava

C. A. Ninan, Susan Abraham, L. Sandhyavathi Bai,  
P. N. Chandrasekharan Nair, and Philomena Kuriachen<sup>1</sup>

Two varieties of cassava, M4 and H.165 (accession numbers M.67-01 and M.72-10), were selected for studies on the lipid metabolism in cassava mosaic-infected plants. There was a decrease in total lipids, phospholipids, and triglycerides in the leaves and petioles of both infected varieties.

Diseases exert a profound influence on the metabolism of the host plant. Diener (1960) reported a high concentration of asparagine and glutamine in virus-infected cherry and

peach leaves. Accumulation of asparagine was also reported in maize plants infected by maize rough dwarf virus (Harpaz and Applebaum 1961). Previous studies have shown that in mosaic-infected cassava, carbohydrate and nitrogen metabolism are altered due to the virus infection (Beck and Chant 1958; Ala-

<sup>1</sup>Department of Botany, University of Kerala, Trivandrum, India.

gianagalingam and Ramakrishnan 1970, 1974). Ramakrishnan et al. (1969) found that the respiratory rate in mosaic-infected cassava leaves is higher than that in healthy leaves. Alagianagalingam and Ramakrishnan (1969) found higher quantities of phosphorus, calcium, and sodium in mosaic-infected cassava leaves. There was less magnesium and iron than in healthy leaves.

## Materials and Methods

Two varieties of cassava, M<sub>4</sub> and H.165, were selected for the study. In each variety, a completely healthy and a diseased plant were selected for lipid estimation. Leaves of uniform maturity from plants grown in the same field were used for analysis. Total lipids, phospholipids, and triglycerides of leaves and petioles in both varieties were determined.

The tissues were extracted twice at 60 °C with ethanol-ether (3:1 v/v) for 2 h followed by chloroform-methanol extraction (1:1 v/v, also twice). The extract was centrifuged each time at 1500 g for 30 min. The combined supernatant was made up to a known volume with ethanol and samples used for the estimation of the lipids.

Total lipids were estimated by the gravimetric method (Brand 1963). Phospholipids were determined by the Ackermann and Toro (1963) methods. Triglycerides were estimated using florisil column to separate the phospholipids, hydrolyzing the eluted triglycerides, and estimating the glycerol liberated (Van Handel 1957).

## Results and Discussion

Diseased plants recorded reduction in total lipids in both the leaves and petioles (for M<sub>4</sub>, 7.5 and 12.2%; H.165, 4 and 8.5%). The percentage reduction in phospholipids in leaves and petioles was: M<sub>4</sub>, 18 and 54.6%; H.165, 18 and 72%. There was a reduction in triglyceride of 11 and 19% in the leaves of M<sub>4</sub> and H.165 respectively, and of 39 and 28% in petioles.

The reduction in lipid metabolism in cassava mosaic-infected cassava plants observed in this study may be due to the decreased synthesis or

increased breakdown of lipids. Carbohydrate metabolism is closely interrelated to lipid metabolism; it is possible that the reduction in carbohydrate metabolism in cassava mosaic-infected plants may also be responsible for the reduction in lipid metabolism.

This study has been made possible through the efforts of Prof A. Abraham, University of Kerala (now in the FAO) who had assembled a vast collection of germ plasm of root and tuber crops in this department. We are grateful to him for access to this material. We are thankful to the United States Department of Agriculture for a generous grant which enabled us to maintain this valuable germ plasm for study. Thanks are also due to Prof P. A. Kurup, Head of the Department of Biochemistry, University of Kerala, for providing necessary facilities.

- Ackermann, P. G., and Toro. In Frankil, S. and Reitman, S., eds., *Gradwohl's clinical laboratory methods and diagnosis*. Mosby. St. Louis, MO, 1963, 258.
- Alagianagalingam, M. N., and Ramakrishnan, K. *Studies on a virus disease of tapioca (Manihot esculenta Crantz.) I. Water relations and mineral metabolism*. Madras Agri. J. 56(6), 1969, 406-411.
- Studies on a virus disease of tapioca (Manihot esculenta Crantz). II. Carbohydrate metabolism*. Madras Agri. J. 57(2), 1970, 55-62.
- Effect of cassava mosaic virus on the nitrogen metabolism of cassava (Manihot esculenta Crantz)*. Madras Agri. J. 61, 1974, 18-26.
- Beck, B. D. A., and Chant, S. R. *A preliminary investigation on the effects of mosaic virus on Manihot utilisissima Pohl. in Nigeria*. Trop. Agric. Trin. 35, 1958, 59-64.
- Brand, S. In Frankil, S., and Reitman, S., eds., *Gradwohl's clinical laboratory methods and diagnosis*. Mosby. St. Louis, MO, 1963, 251.
- Diener, T. G. *Free amino acids and amides in healthy and virus infected cherry and peach leaves*. Phytopathology, 50, 1960, 141-145.
- Harpaz, I., and Applebaum. *Accumulation of asparagine in maize plants infected by maize rough dwarf virus and its significance in plant virology*. Nature, 192, 1961, 708-711.
- Ramakrishnan, K., Nambiar, K. K. N., and Alagianagalingam, M. N. *Physiology of virus infected plants*. Proc. Indian Acad. Sci. 69B, 1969, 104-114.
- Van Handel, E., and Zilversmit, D. B. *Micro-method for direct determination of serum triglycerides*. J. Lab. Clin. Med. 50, 1957, 152-157.

## Cassava Bacterial Blight in Taiwan

L. S. Leu<sup>1</sup>

Common bacterial blight, the most important cassava disease in Taiwan, was probably present before 1945. The disease is systemic in nature and transmitted primarily by cuttings contaminated with bacteria and secondarily by wind-borne water. Angular leaf spots, wilting, defoliation, gum exudates on leaf lobe, stipule, stem, especially on the latter two, and death of plants are caused by vascular-invading bacterium *Xanthomonas manihotis*, which confines itself to the genus *Manihotis* and shows poor survival ability in the soil. The disease was induced by using bacterial suspension, dipping of healthy cuttings, injecting into young stems, spraying of whole plants, cutting leaves of young plants with contaminated scissors, and pouring into injured roots of young plants.

Cassava *Manihot utilissima* has been cultivated in Taiwan for more than 80 years. At present, 22 000 ha of cassava are grown on the island where the total arable land is 915 000 ha. Cassava is the 8th largest crop in Taiwan next to rice, sweet potato, sugar cane, peanut, soybean, tea, and corn. Cassava is grown mostly on marginal lands in mountain hills and slopes, or in flat areas without irrigation. The total yield is close to 330 000 tons annually with an average yield of 16 tons/ha where the crop is grown for 1–2 years. Most roots are used for starch production and only 20% is made as cut chips for animal feed. Recent starch production reached 65 000 tons and is generally used as adhesive for eel feeding materials, textiles, paper, and paperboards, or as raw materials for producing glucose, antibiotics, and sodium glutamate. The requirement for cassava starch is still growing.

Some parasitic fungi (*Cercospora cassavae*, *Colletotrichum manihoticola*, *Guignardia manihoticola*, *Irpex lacteus*, *Macrophoma cassavae*, *Pellicularia rolfsii*, *Phoma manihotina*, *Phyllosticta cassavae*, and *Sclerotinia sclerotiorum*) of cassava have been reported (Sawada 1919, 1955). These and possibly others are probably present in Taiwan. However, most do not cause serious damage except common bacterial blight (CBB), known as bacterial wilt or "gumming disease" locally. Virus diseases do not cause any damage although occasionally mosaic-like symptoms can be seen on some introduced varieties.

Serious damage from CBB was first noted at Puli, central Taiwan, 1963, though the disease probably existed before 1945 (Mau 1951). Since then the disease has become island-wide,

and some fields have been abandoned. The disease was caused by *Xanthomonas manihotis* (Leu and Chen 1972).

### Materials and Methods

The diseased plants were collected mostly from Puli and various other areas. The bacteria were isolated from diseased tissues or gum substances present within tissues on potato dextrose agar (PDA) at room temperature or at 26–30 °C in the incubator. After bacterial colonies grew out 1–2 days later, they were further streaked. Colonies which developed from single cells were then transferred to PDA. The culture was renewed by new isolates or sometimes from the culture stored in the laboratory or in a refrigerator or the bacterial suspension was absorbed by small brick pieces and then kept dry in a refrigerator.

Symptoms were described both from naturally infected plants and those of artificially inoculated ones. The materials were also used for histological studies. Both paraffin and free hand sections were observed.

For inoculation, a thick bacterial suspension prepared from the culture on PDA was introduced to cuttings: (1) by dipping the cuttings for 1–2 min, draining and planting; and also for 1–2-month-old plants, (2) by injecting below the apical meristem; (3) by spraying on leaves at dusk; or (4) by pouring the bacterial suspension into an injured root. "Wu-Chi," the most widely cultivated variety, was used exclusively except as otherwise mentioned. Cutting of leaves by contaminated scissors was also tried.

Survival of the bacteria in the soil was determined by planting healthy cuttings into flats prepared: (1) by pouring the bacterial suspension into wet soil; and (2) by mixing soil with sliced diseased plantlets.

For morphological studies, the bacteria were

<sup>1</sup>Plant Pathology Division, Plant Protection Center, Wufeng, Taichung 431, Taiwan, Republic of China.

shadowed with chromium tungstic oxide and observed by electronmicroscope. The samples were prepared from those inoculated on PDA at 26 °C for 24 h. Physiological studies followed standard methods. Thermal death point was determined by pipetting bacterial suspension into a 1-mm diameter glass tube, sealing the end, and treating in a temperature-adjusted water bath for 10 min.

## Results

More than 80% of 150 pieces of tissues grew mucoid and colourless colonies on PDA 1–3 days after isolation. After single cell cultures, more than 30 isolates were tested for their pathogenicity by injecting the bacterial suspension near the apical meristem. No differences in pathogenicity were observed.

After the dipped cuttings sprouted to 1–6 cm or 10 cm high, the leaves wilted and the plantlets died in a few days. Before death, gum was exuded on the stipules and the stem, being white at the beginning and changing to golden yellow and then brown. The gum exudates swelled and turned "spongy" and white when water was available (Fig. 5). The bacteria within "spongy" exudates were thus spread by wind-borne rain to nearby plants. The tissues where gum protruded were sunken, irregular, spindle-shaped but enlarged longitudinally, turned to purplish and finally blackened and caused the death of the plants by girdling the stem. The same syndrome was observed when the plant was derived from bacteria-contaminated cuttings.

In larger plants, wilting occurred totally or laterally. When death of plants was not so acute, buds from each node sprouted in situ but then wilted, died, and usually exuded gum. Gum exudate could also be observed on green capsules, but seeds were gum-free. Discoloration of vascular tissues could be observed on the stem and also on vascular tissues of swollen roots (Fig. 6). However, no destruction of root and gum exudates was observed.

The diseased plants could be observed throughout all seasons, although epidemics occur when plants are young and the weather is warm and wet (March–November). In warm winter, gum exudate could be observed on matured tissues of the stem, particularly in Brazil No. 4 variety.

When plants were injected with bacterial suspension, gum usually exuded from the point

of injection and then spread to upper parts of stems and stipules. Infection was high and usually reached 100%.

After spraying, wilting and gumming of plants occurred in 10–20 days. About 10% of the inoculated plants left uncovered died, and 90–100% of those covered with plastic bags died after inoculation.

Water soaking symptoms were not observed when very young plants were uncovered, and were not conspicuous even when covered with a plastic bag. However, water soaking lesions were clear when robust growing plants were inoculated and covered with a plastic bag. The lesions developed to angular leaf spots a few days after inoculation (Fig. 3). Gum exudates also occurred from angular spots when humidity was high. Angular leaf spots sometimes coalesced and formed necrotic bands. Gumming on stipules and stems followed and wilt then occurred. Plants grown in rich soil showed recovery after a few leaves wilted and defoliated; however, gum exuded heavily on the stem tissues. Recovery of diseased plants also took place in newly planted fields rotated with summer radish. Heavy manure had been applied and resulted in less disease.

Pouring the bacterial suspension onto the injured root caused wilting and death of the plants 3–4 weeks after inoculation in the summer. Only 1 out of 5 plants was infected in each of two tests. Symptoms developed mostly near apical young tissues even in rather small plants (15–20 cm high).

Leaf blades cut with bacteria-contaminated scissors wilted and defoliated without gumming. The leaves later wilted, sometimes exuding gum on stipules and stems. Plantlets died in 1–2 months after inoculation. However, death occurred faster in some varieties, correlating well with their degree of resistance in the field.

For screening resistant varieties, cuttings of different varieties were dipped into the bacterial suspension and then planted. All 21 tested varieties showed 50–100% infection. On average, 75.2% of plants wilted and died, although 67% of the widely cultivated variety "Wu-Chi" wilted and died. For some other untested varieties, all showed symptoms and high disease incidence including Brazil No. 4.

Host range of the bacterium was confined to cassava. Injections near the apical meristem of the seedlings of tomato, watermelon, lettuce, cucumber, sorghum, and lima bean, and also

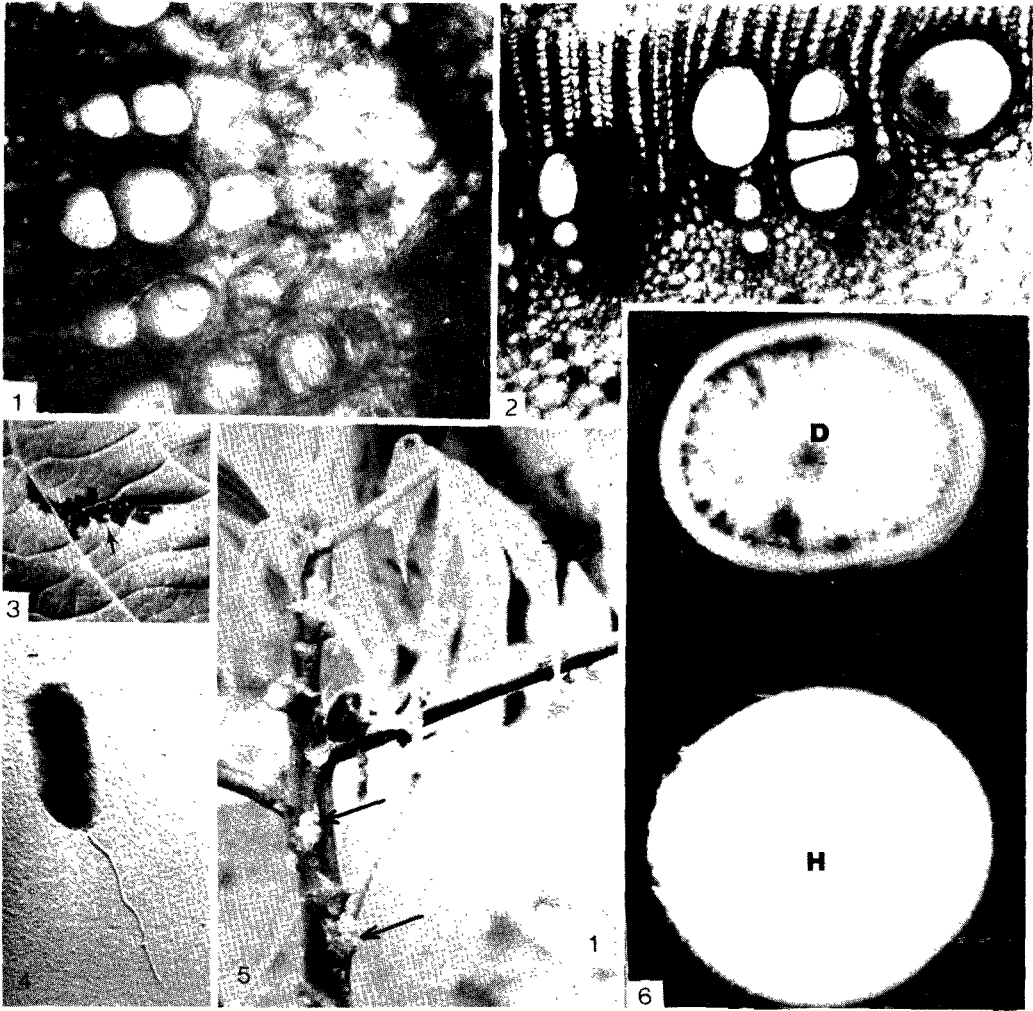

Fig. 1 Free-hand section shows black-coloured substances filling some of the integrated vessels. Fig. 2. Free-hand section shows black-coloured substances filling vessels and parenchymatous cells. Fig. 3. Angular leaf spots on cassava leaf; note gum exudate on the spots (indicated by arrow). Fig. 4. Polar uniflagellated cells of *Xanthomonas manihotis*. Fig. 5. Gum exudate showing "spongy" area. Fig. 6. Vascular bundles turned black in root of diseased plant (D) but white in healthy plant (H).

into trees (*Bischofia trifoliata*, *Codiaeum variegatum*, and *Euphorbia pulcherrima*) all failed to show symptoms. Negative results were also obtained by pouring the bacterial suspension into the injured roots of the above-mentioned seedling plants.

Ability of the causal bacterium in the soil to induce the disease showed that either 3 out of 9 or 2 out of 12 plants wilted and died respectively, soon after cuttings were planted in the flat. The bacterial suspension was poured and mixed with soil and infected plants were

chopped and mixed with the soil. However, if the cuttings were planted 1 or 2 weeks later, no symptoms appeared. The experiences in the field also demonstrated that not all replanted cuttings on the rogued sites of the wilted plants showed symptoms.

CBB could be transmitted primarily by bacteria-contaminated cuttings and secondarily by wind-borne water carrying bacteria. However, some insects may transmit the disease, such as bees.

Losses caused by CBB differed from field to

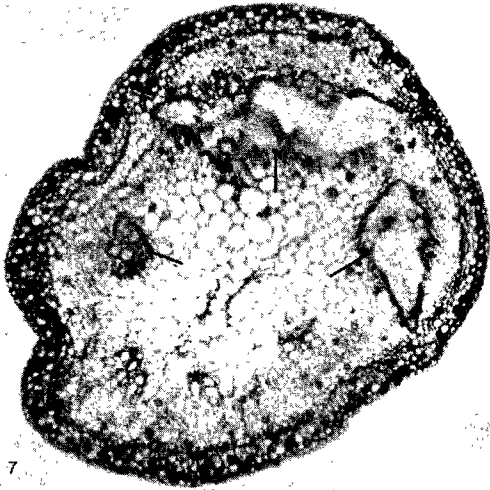

Fig. 7 Paraffin section shows "pocket" in the stipules.

field. In the most severe cases, the field had to be abandoned. Some 30% loss was experienced where the disease was endemic. Control measures such as precaution in selecting healthy cuttings and roging of the young diseased plants were practiced.

Histological studies revealed that vessels were attacked, with brownish black substances filling some of them and nearby parenchymatous cells in the vicinity of the pith (Fig. 2). In phloem cells similar substances were also observed. Some vessels disintegrated and dissolved (Fig. 1), presumably by enzymatic action. The dissolution of the tissues was initially along outer vessels but then expanding and forming a pocket. Several pockets were observed in the same cross section (Fig. 7). As the pocket enlarged, the epidermis erupted and gum substances containing polysaccharides and the bacteria were excreted. Pith tissues were free from infection and remained intact (Fig. 1-2).

The bacterium is rod-shaped with round ends, unflagellated at polar (Fig. 4), no capsule, gram-negative but tended to be positive when aged. Average measurement was  $0.9-1.5 \times 1.8-3.2 \mu\text{m}$ .

The bacterium grew poorly on nutrient agar, circular, convex, entire, and filiform on agar stroke, no odour, without fluorescence, milky white in colour, and sticky. On PDA surface, growth was excellent, milky white, mucoid, but when stable the growth was only along the

stable line. On liquid medium, growth was membranous and tended to be ring-form when shaken and left standing overnight. Temperature range was  $14-36^\circ\text{C}$ , with an optimum at  $30-34^\circ\text{C}$ . Thermal death point was  $52^\circ\text{C}$ . Growth was favoured between pH 6.7-8. No growth occurred at 3, 3.5, and 4% sodium chloride solution but did with 2 and 2.5% solution.

Very weak growth and a slight acid production were obtained with dextrose, sucrose, D-xylose, D-fructose, arabinose, and cellobiose. Lactose gave no growth, and the starch was hydrolyzed. In litmus milk, growth was slow and a slight reduction occurred. Liquefaction began on the ninth day. Indol was not formed even being cultivated for 15 days, but hydrogen sulfide formed in 6-7 days (opposite results were obtained by C. T. Chen, from different isolates; personal communication 1975). Nitrates could not be used. Catalase reaction was positive; also positive for cytochrome oxidase; Voges-Proskauer reaction was negative.

No visible mutants, or changes in pathogenicity, were noted. Older (1 month to several months) cultures in the laboratory, and recultures (1-4 years), all induced the same degree of disease incidence as those of freshly isolated cultures.

## Discussion

There have been four bacterial diseases in cassava in the world (Elliott 1951). Symptomatology of the disease and morphology and physiology of the bacterium all indicated that the disease studied was caused by *X. manihotis*, thus the name common bacterial blight was applied. CBB has been reported in Central and South America, and some parts of Africa (Lozano 1975). Detailed studies on this disease have been reported (Lozano and Sequeira 1974a, b).

Since no resistant germ plasm is present in Taiwan, we are unable to control the disease by using resistant cultivars. Through the courtesy of CIAT, we introduced some cassava seeds including those with resistance from crosses with M Col 647 in August 1975. Seedlings were raised and screening for resistance is under way. Recommended control methods such as using bacteria-free planting materials, roging the diseased plants, rotation with other crops, avoiding the overlapping of the 1- and 2-year-

old crops, are all difficult to practice effectively, except roguing. Distribution of the bacteria-free planting materials is scheduled to be planted by using the tip rooting method for local varieties.

Microbial gum composed of D-glucose, D-mannose, D-glucuronic acid, acetic acid, and pyruvic acid (Chen and Tsou 1974) is produced by *X. manihotis* in a sucrose medium. It is not surprising that bacteria are used to produce gum, such as *X. campestris*, the causal agent of black rot disease of crucifer, used to produce Xanthan gum (Rogovin et al. 1961). The gum probably protects the live bacteria when it is dry and releases the bacteria when it is wet.

This systemic bacterial disease is the biggest problem for cassava growers in Taiwan at the present time.

Chen, W. P., and Tsou, C. H. *Microbial gum: a potential new product from sucrose*. Proc. Int. Soc. Sugar Cane Technol. 15, 1974, 1877-1881.

Elliott, C. *Manual of bacterial plant pathogens*. Chronica Botanica Co., USA, 1951, 186p.

Leu, L. S., and Chen, C. T. *Bacterial wilt of cassava (Manihotis utilissima Pohl.) caused by Xanthomonas manihotis (Arthaud-Berthet) Starr*. Plant Prot. Bull. 14, 1972, 17-26.

Lozano, J. C., and Sequeira, L. *Bacterial blight of cassava in Colombia: I. Etiology*. Phytopathology, 64, 1974a, 74-82.

*Bacterial blight of cassava in Colombia: II. Epidemiology and control*. Phytopathology, 64, 1974b, 83-88.

Lozano, J. C. *Bacterial blight of cassava*. PANS, 21, 1975, 38-43.

Mau, S. C. *Cassava in Taiwan*. Taiwan Special Crops, No. 8, Bank of Taiwan (In Chinese), 1951, 80p.

Rogovin, S. P., Anderson, F. F., and Cadmus, M. C. *Production of polysaccharide with Xanthomonas campestris*. J. Biochem. Microbiol. Tech. Eng. 3, 1961, 51-63.

Sawada, K. *Descriptive catalogue of Taiwan fungi. Part I*. Agric. Exp. Sta., Gov. Formosa Special Bull. No. 19, 1919.

Sawada, K. *Descriptive catalogue of Taiwan (Formosan) fungi, Part II*. Coll. Agric., National Taiwan Univ., Spec. No. 8, 1955, 268p.

## Factors Affecting the Incidence of Cassava Bacterial Blight in Africa

E. R. Terry<sup>1</sup>

Cassava bacterial blight (*Xanthomonas manihotis*) is a widespread and damaging disease in Africa. Its severity in Africa varies with locality and climatic conditions. Factors that may affect its severity are soil type, climate, cultural practices, and varieties. Distribution and economic importance of CBB in Africa, and results of epidemiological studies, are included.

Cassava bacterial blight (CBB), caused by *Xanthomonas manihotis*, is a widespread and damaging disease in several countries of South America, Africa, and Asia (Lozano and Booth 1974). In Africa, it was first reported in Nigeria (Williams et al. 1973) and subsequently in Zaïre (Hahn and Williams 1973), Cameroon (Terry and Ezumah 1974), and Ghana and Togo (Persley unpublished data).

The extent of damage caused by CBB varies with locality and climate. The regions most severely affected are probably Zaïre and mid-

western and eastern Nigeria. In West Africa, it is more prevalent during the rainy season (April-September).

The epidemiology of a disease may be affected by several, often interrelated, factors including soil type, climate, cultural practices, and crop variety.

The following terms are used according to definitions proposed by the Federation of British Plant Pathologists (1973): *Incidence* — frequency of occurrence of disease, expressed as the proportion of plants affected in a given population; *Severity* — intensity of disease in an individual plant expressed as a rating on a numerical scale.

<sup>1</sup>International Institute of Tropical Agriculture, P.M.B. 5320, Ibadan, Nigeria.

old crops, are all difficult to practice effectively, except roguing. Distribution of the bacteria-free planting materials is scheduled to be planted by using the tip rooting method for local varieties.

Microbial gum composed of D-glucose, D-mannose, D-glucuronic acid, acetic acid, and pyruvic acid (Chen and Tsou 1974) is produced by *X. manihotis* in a sucrose medium. It is not surprising that bacteria are used to produce gum, such as *X. campestris*, the causal agent of black rot disease of crucifer, used to produce Xanthan gum (Rogovin et al. 1961). The gum probably protects the live bacteria when it is dry and releases the bacteria when it is wet.

This systemic bacterial disease is the biggest problem for cassava growers in Taiwan at the present time.

Chen, W. P., and Tsou, C. H. *Microbial gum: a potential new product from sucrose*. Proc. Int. Soc. Sugar Cane Technol. 15, 1974, 1877-1881.

Elliott, C. *Manual of bacterial plant pathogens*. Chronica Botanica Co., USA, 1951, 186p.

Leu, L. S., and Chen, C. T. *Bacterial wilt of cassava (Manihotis utilissima Pohl.) caused by Xanthomonas manihotis (Arthaud-Berthet) Starr*. Plant Prot. Bull. 14, 1972, 17-26.

Lozano, J. C., and Sequeira, L. *Bacterial blight of cassava in Colombia: I. Etiology*. Phytopathology, 64, 1974a, 74-82.

*Bacterial blight of cassava in Colombia: II. Epidemiology and control*. Phytopathology, 64, 1974b, 83-88.

Lozano, J. C. *Bacterial blight of cassava*. PANS, 21, 1975, 38-43.

Mau, S. C. *Cassava in Taiwan*. Taiwan Special Crops, No. 8, Bank of Taiwan (In Chinese), 1951, 80p.

Rogovin, S. P., Anderson, F. F., and Cadmus, M. C. *Production of polysaccharide with Xanthomonas campestris*. J. Biochem. Microbiol. Tech. Eng. 3, 1961, 51-63.

Sawada, K. *Descriptive catalogue of Taiwan fungi. Part I*. Agric. Exp. Sta., Gov. Formosa Special Bull. No. 19, 1919.

Sawada, K. *Descriptive catalogue of Taiwan (Formosan) fungi, Part II*. Coll. Agric., National Taiwan Univ., Spec. No. 8, 1955, 268p.

## Factors Affecting the Incidence of Cassava Bacterial Blight in Africa

E. R. Terry<sup>1</sup>

Cassava bacterial blight (*Xanthomonas manihotis*) is a widespread and damaging disease in Africa. Its severity in Africa varies with locality and climatic conditions. Factors that may affect its severity are soil type, climate, cultural practices, and varieties. Distribution and economic importance of CBB in Africa, and results of epidemiological studies, are included.

Cassava bacterial blight (CBB), caused by *Xanthomonas manihotis*, is a widespread and damaging disease in several countries of South America, Africa, and Asia (Lozano and Booth 1974). In Africa, it was first reported in Nigeria (Williams et al. 1973) and subsequently in Zaïre (Hahn and Williams 1973), Cameroon (Terry and Ezumah 1974), and Ghana and Togo (Persley unpublished data).

The extent of damage caused by CBB varies with locality and climate. The regions most severely affected are probably Zaïre and mid-

western and eastern Nigeria. In West Africa, it is more prevalent during the rainy season (April-September).

The epidemiology of a disease may be affected by several, often interrelated, factors including soil type, climate, cultural practices, and crop variety.

The following terms are used according to definitions proposed by the Federation of British Plant Pathologists (1973): *Incidence* — frequency of occurrence of disease, expressed as the proportion of plants affected in a given population; *Severity* — intensity of disease in an individual plant expressed as a rating on a numerical scale.

<sup>1</sup>International Institute of Tropical Agriculture, P.M.B. 5320, Ibadan, Nigeria.

Table 1. Effect of soil type and fertilizer application on CBB incidence in box experiment.

Soil type	% Plants infected <sup>a</sup>		% Plants dead <sup>a</sup>	
	Control	Fertilizer <sup>b</sup>	Control	Fertilizer <sup>b</sup>
Egbeda	74	45	63	35
Ogbomosho	90	90	70	63
Warri <sup>c</sup>	74	74	74	63

<sup>a</sup>Two replicates, 10 plants per replicate.

<sup>b</sup>Fertilizer: N(Urea): 200 ppm N; S(SSP): 100 ppm P; K(KCL): 100 ppm K.

<sup>c</sup>Lime added to Warri soil at rate of 1 ton Ca(OH)<sub>2</sub>/ha.

## Soils

### Field Observations

Surveys conducted in Nigeria and Zaïre suggest that CBB is more severe on cassava planted on infertile, sandy soils (Ezumah and Terry 1974). Glaser and Ogbogu (1974) also report that in Nigeria the disease causes greater crop loss on sandy soils and in fields under continuous cassava.

### Effects of Soil Toposequence

Cassava variety Ojunkaiye was planted at IITA in mid March 1975 on six soil toposequences down a slope. There were four plots, each containing 16 plants. The toposequences varied from well-drained upper levels to poorly drained hydromorphic lower levels.

The plants were infected naturally with CBB and by August they showed severe symptoms. Individual plants were then rated for severity on a 0–5 scale: 0, no symptoms; 1, angular leaf spots; 2, leaf wilt, gum exudation; 3, defoliation; 4, some tip die-back; 5, death. The mean rating of four replicates was taken as the disease index for each toposequence. Groundwater levels were monitored at several positions on the slope at 4-day intervals during the season.

### Results

There is a statistically significant difference ( $p = 0.01$ ) in disease incidence between plants growing in waterlogged soil at the bottom of the slope (disease index 2.2) and those in better-drained soil further up the slope (4.4). Plants in waterlogged soil were smaller and less vigorous, but there was less defoliation and death due to CBB. Soil moisture changes along this slope were confounded with soil texture; wet soils near the bottom were sandy

loams whereas the drier soils near the top were loamy sands.

### Greenhouse Experiments

The effects of soil type and the addition of NPK fertilizers on disease development were investigated in two experiments, one conducted in pots, the other in boxes. Both experiments were in randomized complete blocks, with six soil treatments repeated twice with 10 plants per plot.

Three soils (Egbeda, sandy clay loam, pH 6.2; Ogbomosho, loamy sand, pH 6.3; Warri, loamy sand, pH 5.0) were used, with and without NPK fertilizer. Variety 60444 was used as an indicator for CBB. Cuttings were randomly selected from diseased plants. Plants were rated for disease symptoms on a 0–5 scale over 4 months.

### Results and Discussion

There were no statistically significant differences among soil treatments in the pot experiment. However, there was a trend towards less infection and death in fertilized than in unfertilized soil for all soil types, especially in Warri soil.

In the box experiment (Table 1), there were significant differences ( $p = 0.01$ ) among soil types and NPK treatments. There were fewer infected and dead plants in the Egbeda soil than in the Ogbomosho and Warri soils. Similarly, there were fewer infected and dead plants in the fertilized soils than the unfertilized soils.

These results suggest that the disease is most severe on plants grown in low-nutrient soils. The indication that the addition of NPK fertilizers may decrease the number of plants killed by CBB has implications for disease control and efficient resistance screening, and

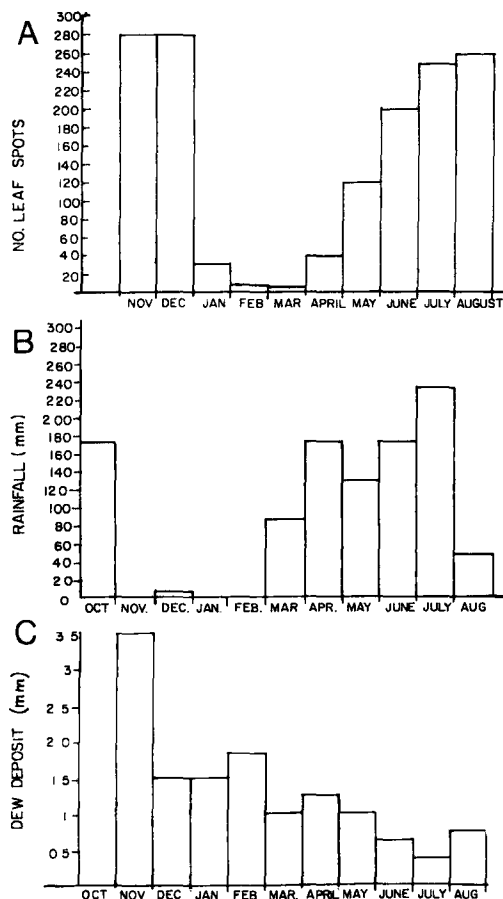

Fig. 1. (a) Seasonal distribution of leaf spots on *Isunikakiyan*; (b) monthly rainfall at IITA, Ibadan; (c) dew deposit distribution at IITA, Ibadan (data for 1973-1974).

suggests that there is a strong correlation between plant vigour and CBB resistance.

These trends are being further investigated with larger numbers of plants. The more precise effects due to single nutrient elements are also being investigated.

### Climate

CBB symptoms range from angular leaf spots to defoliation and death. However, angular leaf spots are the only continuing evidence of CBB since other symptoms occurring alone are not specific for CBB.

The incidence of CBB in a field of 288 plants of *Isunikakiyan* was assessed by counting the number of plants with angular leaf spots at

monthly intervals from November 1973 to August 1974. Climatic data for the period, notably rainfall, temperature, relative humidity, and dew deposit were recorded.

### Results

The seasonal distribution of CBB is illustrated in Fig. 1a and 2a. The total monthly rainfall (Fig. 1b), dew deposit (Fig. 1c), monthly relative humidity (Fig. 2b), and monthly mean temperature (Fig. 2c) are compared with the disease distribution.

There was a decrease in the incidence of angular leaf spots after the rains subsided in November. Leaf spot incidence remained low from November until March and then began to increase in April, and continued to do so until August of the following year. This cycle appears to be correlated with rainfall distribution, although the disease did not increase until about 1 month after the rains began in March.

During the dry season (November-March), dew deposit is an important source of leaf wetness (Fig. 1c) and is probably a vital factor in providing sufficient moisture for some bacteria to remain viable during this period.

### Cultural Practices

The effects of cultural practices on the development of CBB were investigated. The practices considered were: (1) planting material: disease-free plants were raised by rooting shoot tips under mist, using the Lozano and Wholey (1974) method. These were compared with plants grown from infected cuttings, both being established in the field in April, at the beginning of the rains; (2) mulching; and (3) weed control.

For chemical weed control, a mixture of "Amiben" (Chloramben) and "Enide" (Diphenamid), at 2 kg/ha of each, was applied to the soil before the disease-free plants were transplanted. For cuttings, a mixture of "Lasso" (Alachlor) and "Cotoran" (Fluometuron) at 1 and 1.5 kg/ha, respectively, was applied to the soil as a preemergence treatment. A postemergence spray of "Paraquat" (3.75 l/ha) was also applied to plots with cuttings 90 days after planting. The effect of chemical weed control on CBB incidence was compared with that of hand-weeding.

### Results

An average of 9.7 plants out of 24 per plot

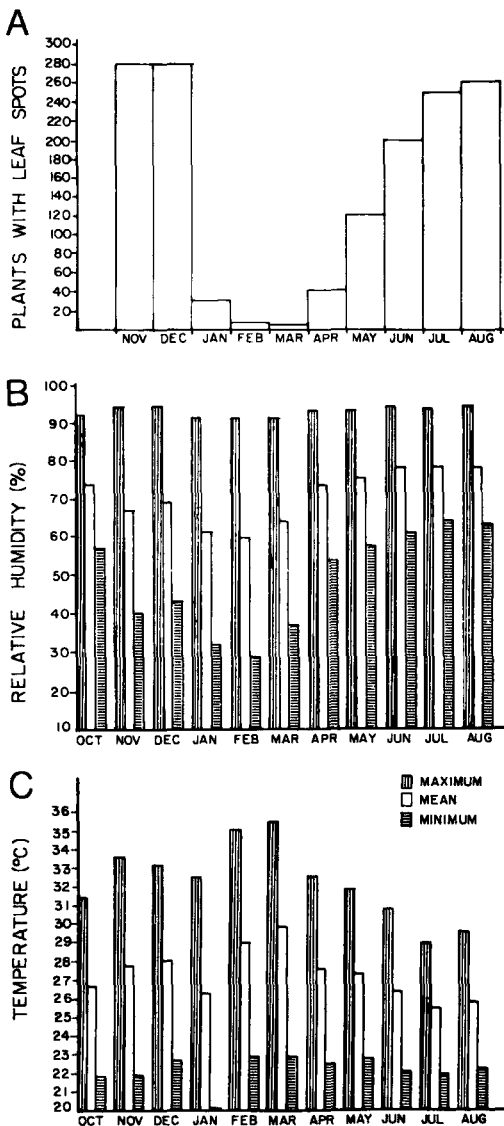

Fig. 2. (a) Seasonal distribution of leaf spots on *Isunikakiyan*; (b) monthly relative humidity, at IITA, Ibadan; (c) monthly mean temperatures at IITA, Ibadan (data for 1973-74).

raised from disease-free material showed CBB symptoms 55 days after planting, compared to only 3.6 raised from infected cuttings. After 85 days, 21.8 and 22.1 plants respectively showed CBB symptoms in the two treatments.

The differences were statistically significant ( $p = 0.01$ ) at 55 days but not at 85 days after planting. This surprising result suggests that

rooted shoot-tips are initially more susceptible to infection than cuttings and should first be established in an area free of CBB if they are to be used as a source of disease-free planting material.

In the hoe-weeding treatment performed 50 days after planting, there was a significant difference ( $p = 0.01$ ) in CBB incidence before weeding and 6 days after. A mean of 4.5 plants out of 24 in the treatment subplots showed symptoms the day before weeding, whereas 6 days after weeding, the mean had increased to 8.8. No such differences were observed when the plots were weeded 80 days after planting. This high incidence of CBB after weeding was probably due to mechanical spread of bacteria during weeding.

Mulching versus non-mulching and hoe-weeding versus chemical weed control had no significant effects on CBB incidence.

## Varieties

The incidence and severity of CBB on three varieties (*Isunikakiyan*, 60444, and 53101) were compared. All three varieties were planted in October 1974 in a  $3 \times 3$  Latin square, with 8 replicates and 15 plants per plot.

Incidence was measured as the number of infected plants per plot. Severity was assessed on a 1-5 scale, where 1 represented no symptoms; 2 angular leaf spots; 3 extensive wilting; 4 defoliation and partial die-back; 5 death.

Ratings were made 5, 7, 9, and 11 months after planting and root yields were recorded after 12 months. These yields were compared to the average yield obtained from these varieties at IITA in October 1972 after 12 months growth, during which time the incidence and severity of bacterial blight was low. The disease ratings recorded in September 1975 (11 months) and root yields are recorded in Table 2.

The varieties differed in the extent of infection and losses sustained. Cultivar 60444 (yield 8.8 t/ha) was more susceptible than 53101 (yield 9.7 t/ha) or *Isunikakiyan* (yield 12.2 t/ha). The 1971-72 yields of the same varieties ranged from 19 to 21 t/ha. While there are other factors which may have contributed to the yield reduction, it seems likely that CBB infection is at least partially responsible.

## Resistance Screening

Varieties were rated on a 1-5 scale of in-

Table 2. Effects of CBB on yield.

Variety	Incidence <sup>a</sup>	Severity <sup>b</sup>	Yield (1975) (t/ha)	Yield (1972) (t/ha)
Isunikakiyan	13.8	2.8	12.2	19
604444	14.7	3.2	8.8	21
53101	13.6	2.9	9.7	20

<sup>a</sup>Mean number of infected plants out of 15 per plot.

<sup>b</sup>1-5 scale of increasing severity (see text).

creasing severity after natural infection at four sites in Nigeria and one in Zaïre.

The ratings of selected clones at three Nigerian sites are recorded in Table 3. At Warri (midwestern Nigeria), 7, 36, 45, and 12% of 202 local cultivars were rated 2, 3, 4, and 5 respectively for CBB resistance.

The data from field screening for CBB conducted at IITA and M'Vauzi (Zaïre) during the 1975 season are summarized in Table 4. More than one half of the IITA families were rated 1 (no symptoms) and 2 (angular leaf spots only), suggesting that breeding has considerably improved the resistance of these families to CBB.

## Discussion

The above results indicate that soil type and fertilizer levels are important factors affecting the severity of CBB although the nature of their effect is not known. Nutrients play an important role in the reduction in severity of many plant diseases but the mechanism of action is often obscure (Goss 1968). Gallegly and Walter (1949) found disease development in bacterial wilt of tomatoes (caused by *Pseudomonas solanacearum*) increased at low K levels and decreased at high N levels. Their results showed the need for medium to high

Table 3. Resistance ratings of clones at three sites in Nigeria.

Disease rating	% Clones		
	Mokwa (north)	Warri (midwest)	Umudike (east)
1	10.0	3.6	0.0
2	82.5	72.6	64.1
3	5.5	17.4	30.5
4	2.0	5.7	5.0
5	0.0	0.7	0.4

levels of N and K to minimize the effects of this disease, and also indicated that N, P, and K must be balanced.

Applications of high levels of nitrogen or unsuitable combinations of N, P, and K increase the severity of bacterial leaf blight of rice, caused by *Xanthomonas oryzae*, while potassium decreases it (Mizukami and Wakimoto 1969). This decrease is more severe on sandy loam or clay soils than sandy soil, in contrast to the situation with cassava bacterial blight.

While CBB was more severe on low-fertility soils in greenhouse experiments, it was observed on the soil toposequences that plants of low vigour had less CBB. A similar effect has been seen in a resistance trial (Jennings, personal communication). The less vigorous plants may be less attractive to insect vectors; however this observation needs to be more closely investigated.

Reports by Rotem and Palti (1969) suggest that dew is an important source of leaf wetness on many crops, especially during the dry season. Dew records in Ibadan (Fig. 1c) show that levels were highest in November after the rains cease, and there continues to be dew deposited throughout the dry season, thus pro-

Table 4. Cassava bacterial blight resistance screening, 1975 season

Location	Source	No. families	Disease rating				
			1	2	3	4	5
Nigeria	Exotic	73	—	—	—	89.8	10.9
	Crosses from advanced yield trial	115	0.8	2.6	19.1	76.5	0.8
	Open-pollinated preliminary yield trial	310	1.2	4.1	18.0	76.4	—
	Low HCN	107	—	0.9	6.5	92.5	—
Zaïre	Zaïre locals	187	—	2.6	28.5	39.1	29.6
	IITA families	164	13.4	40.8	35.3	10.3	—

viding a source of moisture for any bacteria surviving on the leaves.

During hot and dry conditions, the microclimate in the field becomes the decisive factor affecting disease development, since the less favourable the microclimate, the more important becomes the macroclimate (Palti and Rotem 1973).

It is difficult to isolate a single climatic factor when considering its effects on disease development because the optimum conditions for the disease depend upon a complex of climatic factors. Extensive studies over several years with *X. oryzae* on rice in Japan show that a suitable combination of rainfall, humidity, temperature, flood, and typhoon during the growing season is necessary for the development of an epidemic (Mizukami and Wakimoto 1969). An analogous situation probably exists for CBB with some of these climatic factors, but the disease has not been sufficiently well studied for these effects to be known.

Investigations are in progress to determine more precisely the effects of environmental factors on CBB incidence and severity, the variability of the pathogen, and differences in varietal reaction of cassava to the pathogen. A better understanding of these factors is necessary to enable us to modify the farming system so as to favour the crop and not its pathogen.

This work was supported in part by the International Development Research Centre, Ottawa, Canada. The author is grateful to B. T. Kang and F. R. Moorman for information on soil characteristics. R. Dumsday and T. Lawson kindly supplied weather data. The technical assistance of S. Oshinnaiye is warmly acknowledged. I am also grateful to D. Allen, S. Sadik, and W. Steele for their critical reading of the manuscript.

Ezumah, H. C., and Terry, E. R. *Cultural considerations in control of cassava bacterial blight.*

Proc. 1st Workshop on Cassava Bacterial Blight in Nigeria, 1974, 25-32.

Federation of British Plant Pathologists. *A guide to the use of terms in plant pathology.* Phytopath. Paper No. 17. Commonwealth Mycological Institute, London, 1973.

Gallegly, M. E., Jr., and Walker, J. C. *Plant nutrition in relation to disease development. V. Bacterial wilt of tomato.* Amer. J. Bot. 36, 1949, 613-23.

Glaser, H. J., and Ogbogu, F. C. *Problems and experiences of plant protection extension in the control of cassava bacterial blight in East Central State of Nigeria.* Proc. 1st Workshop on Cassava Bacterial Blight in Nigeria. Fed. Agric. Res. Stn., Umudike, Nigeria, 1974, 11-12.

Goss, R. L. *The effects of potassium on disease resistance.* In The role of potassium in agriculture. American Society of Agronomy, Madison, Wisconsin, 1968, 221-241.

Hahn, S. K., and Williams, R. J. *Report to Commissaire d'Etat à l'Agriculture Republic of Zaïre, March, 1973.* IITA, Ibadan, Nigeria, 1973, 12p.

Lozano, C., and Booth, R. H. *Diseases of cassava (Manihot esculenta Crantz).* PANS, 20, 1974, 30-54.

Lozano, C., and Wholey, D. W. *The production of bacteria-free planting stock of cassava (Manihot esculenta Crantz).* World Crops, 26, 1974, 115-117.

Mizukami, T., and Wakimoto, S. *Epidemiology and control of bacterial leaf blight of rice.* Ann. Rev. Phytopathol. 7, 1969, 51-72.

Palti, J., and Rotem, J. *Epidemiological limitations to the forecasting of downy mildews and late blight in Israel.* Phyto Parasitica, 2, 1973, 119-126.

Rotem, J., and Palti, J. *Irrigation and plant diseases.* Ann. Rev. Phytopathol. 7, 1969, 267-288.

Terry, E., and Ezumah, H. C. *Report on root crops disease survey and evaluation of production problems in Cameroon, 22-27th Aug. 1974.* IITA, Ibadan, Nigeria, 1974, 4p.

Williams, R. J., Agboola, S. D., and Schneider, R. W. *Bacterial wilt of cassava in Nigeria.* Pl. Dis. Rept. 57, 1973, 824-827.

## Effect of Potassium and Bacterial Blight on the Yield and Chemical Composition of Cassava Cultivars

G. O. Obigbesan and E. O. Matuluko

Studies on cassava cultivars having different levels of susceptibility to bacterial blight caused by *Xanthomonas manihotis* revealed that the infection exerted differential influence on the mineral nutrient and starch contents of the cultivars. The disease caused a reduction in the macronutrient content, led to a higher accumulation of micronutrients in the diseased leaves, and adversely affected the tuber quality by lowering the percentage starch content. Despite the relatively greater tolerance of the 60506 cultivar, bacterial blight significantly reduced its tuber and starch yields.

Cassava is an important source of food energy for millions of people in the tropics, and there is an ever-increasing demand for cassava starch in the textile and chemical industry. It is also used as livestock feed. To maximize yields it is imperative to have adequate knowledge of the factors limiting production. Thus concerted efforts are being made to better understand the nature and action of cassava bacterial blight, the most devastating of the several bacterial diseases of cassava.

CBB is now recognized as one of the most important factors limiting cassava production. It was first recorded in Brazil (Bondar 1912) and has since been reported in several other countries in South America and Africa (Lozano 1973). Its occurrence in Nigeria was first observed in 1971, and has since assumed epidemic proportions in certain areas of the southern part of the country, especially in the East Central State. Between 1972 and 1973 loss of crops due to this disease was estimated at about 25 million Naira (about \$39 million US) (Ene and Agbo 1974). In Nigeria and Zaïre, where cassava production is highest in Africa, bacterial blight is a potentially more serious disease than mosaic, which might not result in complete loss of the crop.

The symptoms were similar everywhere the disease had been observed, including angular leaf spotting and blight, wilting, tip dieback, copious gum exudation and vascular necrosis of stem and roots (Anon 1973). Cassava blight bacterium is host specific (found only on cassava). Its spread may be related to rainfall patterns (Arene 1974), but the epidemiology in Nigeria is as yet unknown.

### Materials and Methods

Our observations were made on a cassava fertilizer experiment with potassium started in 1973. The detailed procedure was described by Adeniji and Obigbesan (1975). It involved two cassava cultivars, 53101 and 60506, of varying susceptibility to bacterial blight. Observations were made and records were taken between October and November 1974 when the incidence of infection was most severe at the site.

The following symptoms are characteristic of the disease: angular leaf spotting, wilting, gum exudation from the node at the base of petiole, defoliation and tip dieback. These were used in assessing the degree of infection. Since mainly the top portions of the plants were affected, observations were made beginning at the second point of bifurcation of each stem. The number of infected branches on each plant, as well as the total number of branches per plant, were recorded. There were a total of 32 plots. The treatments were four levels of potash (0, 60, 90, and 120 kg K<sub>2</sub>O/ha) with two cassava cultivars and four replications. Percentage infection of the plants in each plot was calculated. The degree of infection in the four replicates of each treatment was then computed to obtain the final mean estimate of infection. The plants were harvested in December 1974 (age 15 months) and the tubers, stems, and leaves in each plot were weighed. The nutrient content in the leaves and starch content of the tubers were determined by conventional methods.

Since the disease is fairly new in Nigeria, it is not clear what time is the most appropriate to collect data. We therefore concentrated on areas where infection was most severe. Dur-

<sup>1</sup>Department of Agronomy, University of Ibadan, Ibadan, Nigeria.

Table 1. Influence of CBB on starch content and yield of two cassava cultivars.

53101			60506		
Degree of infection (%)	Starch content (%)	Yield (t/ha)	Degree of infection (%)	Starch content (%)	Yield (t/ha)
62	24	25	36	23	38
66	22	24	39	20	33
69	21	20	48	19	31
70	22	20	51	21	32

ing the 2-week observation period, we noted that some infected plants developed new leaves. We assumed that branches with new growth were infected.

## Results and Discussion

### Tuber Yields

Table 1 shows the yield of the cassava cultivars in relation to the severity of bacterial infection. The data reflect the obvious greater susceptibility of the 53101 (mean infection 67.2%) compared with 60506 cultivar (mean infection 43.9%), as well as the relatively higher tuber yield potential of the latter (mean yield 33.8 t/ha) compared with the former, 53101 (mean yield 22.2 t/ha). The negative correlation coefficient between the intensity of bacterial blight and tuber yields ( $r = -0.13$  for 53101 and  $r = -0.60$  for 60506) with a pooled average of  $r = -0.70$ , indicate that increasing bacterial infection significantly depressed cassava yields.

In the absence of cassava bacterial blight, mosaic disease probably reduces cassava yields by about 30% in Nigeria and by up to 43% in East Africa (Beck and Chant 1958). Currently cultivated cassava varieties in the country are not free from mosaic disease but yield losses through bacterial infestation could still be determined since mosaic disease is a common factor among them. Tuber yields of 53101 were not significantly reduced by blight although the plants showed a higher percentage of infection than the 60506 cultivar.

### Starch Content

The starch content of the cassava tubers in relation to bacterial infection is shown in Table 1. There were negative correlation coefficients,  $r = -0.59$  (53101) and  $r = -0.24$  (60506) between the percent infection and tuber starch content, thus indicating that bacterial blight

reduced the starch content in the tuber of both cassava cultivars. This reduction in starch content had hitherto not been reported, although Lozano and Sequeira (1973) observed that the bacterium hydrolyzed starch and gelatin. The reduction in tuber starch content was significant at the 5% level in 53101 while it was not significant in 60506 ( $p_{0.05} = 0.4973$ ). Under the circumstances, the relationship between the bacterial blight infection and percent tuber starch content ( $Y$ ) was given by the linear regression equations,

$$Y = 28.15 - 0.08X \text{ (53101) and}$$

$Y = 22.34 - 0.03X$  (60506), where  $X$  is the percentage of plants showing characteristic blight symptoms.

Further evidence that the bacterial blight in effect lowered the percentage starch content of cassava tubers at 15 months is provided in Table 2, at 12 months harvest when there was no incidence of infection. The starch content of cassava increases with the age of the crop, and reaches its maximum after 15–18 months (Obigbesan and Agboola 1973; Rosanow 1973). There was an average reduction of between 5% (53101) and 7% (60506) in tuber starch content of CBB-infected plants (Table 2).

The effects of potash and bacterial blight on the starch yields of the cassava cultivars harvested at 12 and 15 months after planting are presented in Table 2. The decrease in percent starch content ultimately led to a reduction in starch yields (Table 2). The data in this table also show that only at 90 kgK<sub>2</sub>O/ha was there no yield reduction. The highest starch yields were also produced at this K fertilizer level which suggests that the deleterious effect of CBB could be reduced.

### Nutrient Content of Leaves

The mineral contents of randomly sampled healthy and diseased leaves showed that

Table 2. Influence of K and potash and CBB on the starch yield of cassava cultivars.

Age at harvest:	Influence of K on percent starch content of peeled tuber				Influence of potash on starch yields (kg/ha)			
	12 months		15 months		12 months		15 months	
Cultivar:	53101	60506	53101	60506	53101	60506	53101	60506
Incidence of infection:	None	None	67.2%	43.9%	None	None	67.2%	43.9%
0 kgK <sub>2</sub> O/ha	29	28	21	20	3770	5610	3505	5430
60 kgK <sub>2</sub> O/ha	29	29	22	21	4260	6020	3658	5955
90 kgK <sub>2</sub> O/ha	26	28	24	23	4360	6025	4886	7350
120 kgK <sub>2</sub> O/ha	24	27	22	19	4690	5590	4300	5010

the healthy leaves contained higher amounts of macronutrients (N-P-K-Mg) but lower amounts of micronutrients (Fe, Zn, Mn) than the diseased leaves.

Lower concentration of macronutrients in the infected leaves should obviously be expected since the acropetal transportation of nutrients would be disrupted, among other things, by the gum exudates oozing out of the node at the base of the petiole. More work is needed to explain the higher concentration of micronutrients in the same diseased leaves. Both phenomena, however, point to the physiological disorder the disease imparts to the plant itself.

### Conclusion

The observations reported in this paper are in no way exhaustive. They do illustrate the fact that CBB is a seriously devastating disease which does more than reduce crop yield. Tubers of infected plants showed lower starch content. This is most undesirable because the starch and chip industries require tubers with high starch content. The disorder in nutrient status (nutrient imbalance) of infected leaves, resulting from a drastic reduction in the concentration of macronutrients (N content was reduced by about 12%, P by 24%, K by 17% and Mg by 7%) and higher accumulation of micronutrients (e.g. Zn content rose by about 23%, Mn by 7%), may lead to toxicity and decreased resistance to other diseases. The different cultivars exhibit different degrees of tolerance to blight. Thus a combination of blight-tolerant (resistant) varieties and disease-free planting material would reduce losses in large-scale cassava production.

Adeniji, M. O., and Obigbesan, G. O. *The effect of potassium nutrition on the bacterial wilt of cassava*. Nigerian Journal of Plant Protection, 1975 (in press).

Anonymous. *Bacterial wilt disease of cassava*. Advisory Bulletin No 1. Federal Agricultural Research and Training Station, Umudike, Nigeria, 1973.

Arene, O. B. *A short epidemiology of the disease of cassava in Nigeria*. Technical Bulletin No. 7. FARTS, Umudike, Nigeria, 1974, 12-23.

Beck, B. D. A., and Chant, S. R. *A preliminary investigation on the effect of mosaic virus on Manihot utilissima Pohl. in Nigeria*. Trop. Agriculture, Trinidad, 35, 1958, 59-64.

Bondar, G. *Una nova molestia bacteriana das hastes da mandioca*. Chacaras e quintaes, 5, 1912, 15-18.

Ene, L. S. O., and Agbo, F. M. O. *Breeding for resistance to cassava bacterial blight in Umudike*. Proceedings of the First workshop on Cassava bacterial blight in Nigeria. FARTS, Umudike, Nigeria, 1974, 3-6.

Lozano, J. C. *Bacterial blight of cassava (Manihot esculenta Crantz) in Colombia etiology, epidemiology and control*. Ph.D. thesis, University of Wisconsin, Madison, 1972, 114p.

*Bacterial blight of cassava in Central and South America: etiology epidemiology and control*. 3rd International Symposium on Tropical Root Crops. IITA, Ibadan, Nigeria, Dec. 1973.

Lozano, J. C., and Sequeira, L. *Bacterial blight of cassava in Colombia: I. Etiology*. Phytopathology, 63, 1973.

Normanha, S. E. *General aspects of cassava root production in Brazil*. In Proceedings Second International Symposium on Tropical Root and Tuber Crops, Hawaii, 1970, 61-63.

Obigbesan, G. O., and Agboola, A. A. *An evaluation of the yield and quality of some Nigerian cassava varieties as affected by age*. 3rd International Symposium on Tropical Root Crops. IITA, Ibadan, Nigeria, Dec. 1973.

- Okpala, E. U. *Cultural and biological control of bacterial blight of cassava*. In Proceedings of the First Workshop on Cassava Bacterial Blight in Nigeria. FARTS, Umudike, Nigeria, 1974, 33-36.
- Pereira, A. L. G., and Zagatto, A. G. *Etiology of angular leaf spot of cassava (Manihot utilisima)*. Archives de Instituto Biologico, São Paulo, 34, 1967, 153-160.
- Rosanow, M. *Field experimental check on starch yields of cassava in Indonesia*. 3rd International Symposium on Tropical Root Crops. IITA, Ibadan, Nigeria, Dec. 1973.
- Terry, E. R. *Some epidemiological factors affecting the survival and dissemination of Xanthomonas manihots*. Proceedings of the First Workshop in Cassava Bacterial Blight in Nigeria. FARTS, Umudike, Nigeria, 1974, 39-41.

## World Distribution, Identification, and Control of Cassava Pests

Anthony C. Bellotti and Aart van Schoonhoven<sup>1</sup>

Numerous insect and mite pests have been identified as attacking cassava. These pests represent a wide range of insect fauna; more than 100 species have been recorded. Many of these are minor pests and cause little or no economic losses. However recent research has shown that several pests can cause crop losses and must be classified as major pests. These include mites, thrips, stemborers, whiteflies, hornworms, scale insects, and whitegrubs. Many pests, such as mites, whiteflies, scales, whitegrubs, stemborers, ants, termites, are distributed world wide. Others are local pests or limited to one or two continents. Chemical control of cassava pests is uneconomical in many areas where it is a low value crop. Pesticides are expensive and their continual use is impractical for a long season crop such as cassava. Emphasis should be directed toward the use of resistant varieties, biological control, and improved cultural practices. Strict quarantine practices should be enforced to prevent the spread of cassava pests into areas where they are not present.

Insects and mites are limiting factors in cassava production. The recent introduction, and consequent outbreak, of the mite *Mononychellus tanajoa* in West Africa has caused serious crop losses. This is ample evidence for the need for extensive research on cassava pests, knowledge of their geographic distribution and the damage they cause, and the establishment of an effective pest-management program.

CIAT has been able to collect much of the available literature on cassava, and it is now possible for us to get a global view of pest problems. There are numerous pests that attack cassava and they represent a wide range of insect fauna. Many are of minor importance and cause little or no economic losses, while others can cause considerable damage.

### Insects Attacking Vegetative Planting Material

Cassava is propagated by vegetative stem cuttings. The planting of insect-free and un-

damaged cuttings is most important.

Infestation of cuttings by white scale *Aonidomytilus albus* can reduce germination up to 50%. Infested cuttings were dipped in insecticide solutions, but they still germinated poorly. We recommend that scale-infested cuttings not be used as propagation material.

The cassava fruitflies *Anastrepha pickeli* and *A. manihoti* cause damage to stems by introducing secondary bacterial rots, which may cause reduction in yield and the loss of stake planting material. Infested stakes are easily distinguishable by the darkened and rotted pith region of the stem. Infected cuttings should not be used as propagating material.

### Pregermination and Postgermination Damage to Cuttings and Young Plants

Stem cuttings and young germinating plants are subject to attack by several insects, including whitegrubs (*Leucopholis rorida* and *Phyllophaga* sp. (Coleoptera Family Scarabaeidae, Cerambycidae)). They destroy the bark of planted cuttings which may then rot and die.

<sup>1</sup>Centro Internacional de Agricultura Tropical, Apartado Aéreo 67-13, Cali, Colombia.

- Okpala, E. U. *Cultural and biological control of bacterial blight of cassava*. In Proceedings of the First Workshop on Cassava Bacterial Blight in Nigeria. FARTS, Umudike, Nigeria, 1974, 33-36.
- Pereira, A. L. G., and Zagatto, A. G. *Etiology of angular leaf spot of cassava (Manihot utilisima)*. Archives de Instituto Biologico, São Paulo, 34, 1967, 153-160.
- Rosanow, M. *Field experimental check on starch yields of cassava in Indonesia*. 3rd International Symposium on Tropical Root Crops. IITA, Ibadan, Nigeria, Dec. 1973.
- Terry, E. R. *Some epidemiological factors affecting the survival and dissemination of Xanthomonas manihots*. Proceedings of the First Workshop in Cassava Bacterial Blight in Nigeria. FARTS, Umudike, Nigeria, 1974, 39-41.

## World Distribution, Identification, and Control of Cassava Pests

Anthony C. Bellotti and Aart van Schoonhoven<sup>1</sup>

Numerous insect and mite pests have been identified as attacking cassava. These pests represent a wide range of insect fauna; more than 100 species have been recorded. Many of these are minor pests and cause little or no economic losses. However recent research has shown that several pests can cause crop losses and must be classified as major pests. These include mites, thrips, stemborers, whiteflies, hornworms, scale insects, and whitegrubs. Many pests, such as mites, whiteflies, scales, whitegrubs, stemborers, ants, termites, are distributed world wide. Others are local pests or limited to one or two continents. Chemical control of cassava pests is uneconomical in many areas where it is a low value crop. Pesticides are expensive and their continual use is impractical for a long season crop such as cassava. Emphasis should be directed toward the use of resistant varieties, biological control, and improved cultural practices. Strict quarantine practices should be enforced to prevent the spread of cassava pests into areas where they are not present.

Insects and mites are limiting factors in cassava production. The recent introduction, and consequent outbreak, of the mite *Mononychellus tanajoa* in West Africa has caused serious crop losses. This is ample evidence for the need for extensive research on cassava pests, knowledge of their geographic distribution and the damage they cause, and the establishment of an effective pest-management program.

CIAT has been able to collect much of the available literature on cassava, and it is now possible for us to get a global view of pest problems. There are numerous pests that attack cassava and they represent a wide range of insect fauna. Many are of minor importance and cause little or no economic losses, while others can cause considerable damage.

### Insects Attacking Vegetative Planting Material

Cassava is propagated by vegetative stem cuttings. The planting of insect-free and un-

damaged cuttings is most important.

Infestation of cuttings by white scale *Aonidomytilus albus* can reduce germination up to 50%. Infested cuttings were dipped in insecticide solutions, but they still germinated poorly. We recommend that scale-infested cuttings not be used as propagation material.

The cassava fruitflies *Anastrepha pickeli* and *A. manihoti* cause damage to stems by introducing secondary bacterial rots, which may cause reduction in yield and the loss of stake planting material. Infested stakes are easily distinguishable by the darkened and rotted pith region of the stem. Infected cuttings should not be used as propagating material.

### Pregermination and Postgermination Damage to Cuttings and Young Plants

Stem cuttings and young germinating plants are subject to attack by several insects, including whitegrubs (*Leucopholis rorida* and *Phyllophaga* sp. (Coleoptera Family Scarabaeidae, Cerambycidae)). They destroy the bark of planted cuttings which may then rot and die.

<sup>1</sup>Centro Internacional de Agricultura Tropical, Apartado Aéreo 67-13, Cali, Colombia.

When young plants (1–3 months) are attacked, the leaves wilt. The larvae feed on the bark of the lower part of the stem, usually below the soil, or tunnel into the cutting. The larvae are white with a darkened head and are 5 cm long. They can usually be located around the cutting or roots of the plant.

Whitegrubs are best controlled with Aldrin (2.5%, 50 kg/ha) and Furadan (3 g/m<sup>2</sup>) applied below the cutting in the soil. Insecticidal dip treatments have not proved as successful as soil application. A muscardine fungus *Metarrhizium anisopliae* is pathogenic to the grub and there is evidence that this may be an effective control method.

Attacks occur frequently when the cassava crop is rotated after pastures.

### Cutworms

Cutworms can injure young plants in three principal ways: (1) The surface cutworms, such as the black cutworm *Agrotis ypsilon* eat off plants just above, at, or a short distance below the surface of the soil leaving the plant lying on the ground. The larvae are greasy gray to brown, with faint lighter stripes; (2) The climbing cutworms such as the southern armyworm *Prodenia eridania* climb the stems and eat buds and foliage and may girdle stems causing plants to wilt and die. The full-grown larvae are dark gray to nearly black and marked with lateral yellow stripes; (3) The subterranean cutworms remain in the soil to feed on roots and underground parts of the stems, causing a loss of planting material. Losses of young plants may reach 50% making it necessary to replant. Cutworm attacks occur sporadically but are more frequent when cassava follows corn in rotation.

Cutworms attacking plants above or at ground level may be controlled effectively with poison baits (10 kg of bran or sawdust, 8–10 l of water, 500 g of sugar or 1-1 of molasses and 100 g of Dipterex for ¼ to ½ ha). For underground cutworms soil applications of Aldrin or Furadan around the cuttings are effective.

### Termites

Termites will attack cassava in the lowland tropical areas. They feed on planting material and roots of growing plants, and prevent the establishment of cuttings. They are a serious problem in areas with prolonged dry seasons.

Insecticide treatments may give effective control.

### Crickets

Crickets damage cassava plants by clipping young shoots after emergence. They can also damage the base of the cassava plant, rendering them more susceptible to lodging by wind.

## Insects Attacking Foliage and Buds

### Thrips

Several species (*Frankliniella williamsi*, *Corynothrips stenopterus*, and *Caliothrips masculinus*) of thrips, all belonging to the family Thripidae, attack cassava. Thrips are major pests in Central and South America and Africa.

The most important species is *F. williamsi* which damages the terminal buds of the plant. The leaves do not develop normally, leaflets are deformed and show irregular chlorotic yellow spots. Stylet damage to the leaf cells during expansion causes deformation and distortion, with parts of leaf lobes missing. Brown wound tissue appears on the stems and petioles and internodes are shortened. The growing points may die, causing growth of lateral buds which also may be attacked, giving the plants a witches' broom-like appearance. The attack is most frequent during dry periods and plants will recover when the rain starts. Thrips can cause a 15–20% yield loss.

Control is best achieved through the use of resistant varieties which are readily available. Resistance is based on leaf-bud pilosity and nearly 50% of the CIAT germ plasm bank (2300 varieties) are highly resistant.

### Mites

Mites, one of the most serious dry season cassava pests, cause serious damage. The green cassava mite *Mononychellus tanajoa*, native to the Americas, causes considerable yield reduction in parts of East Africa. It is spreading to other parts of Africa.

The mite *Tetranychus urticae* is universal but appears to be a significant pest in parts of Asia. *Oligonychus peruvianus* is limited to the Americas and East Africa.

Mites can be found in great numbers on the undersides of leaves during optimum environmental conditions. Usually older plants are more susceptible to attack.

*Mononychellus tanajoa* is green and develops in the apical buds, feeding on young leaves and stems. Leaves are splashed with

Table 1. World distribution of cassava pests.

Insect	The Americas	Africa	Asia
Thrips	X	X	
Mites	X	X	X
Hornworm	X		
Fruitfly	X		
Shootfly	X		
Whiteflies	X	X	X
Stemborers	X	X	
Whitegrubs	X	X	X
Cutworms	X		
Gall midges	X		
Lacebugs	X		
Grasshoppers		X	
Mealybugs	X	X	
Scales	X	X	X
Leafcutter Ants	X	X	
Crickets	X	X	
Termites	X	X	X

yellow spots, lose their normal green colour and develop deformities. The attacked stems become rough and brown. Stems and leaves die from top to bottom. Severe attack results in death of the growing point causing excessive branching.

Damage from *Tetranychus* first shows as yellow dots along the midrib of the leaves, eventually spreading and turning leaves reddish or rusty. Older, basal leaves are attacked first and under prolonged dry periods spread to the upper leaves, causing defoliation and death of the plants.

The attack of *O. peruvianus* is characterized by white dots along leaf veins and margins on the undersides of leaves. These dots are web-bings under which the adult female places her eggs, and where the larvae and nymphs develop. These locations first appear as yellow and later brown dots on the leaf uppersurface. The basal leaves are more readily attacked.

Yield reductions of 40% have been reported in Africa for *M. tanajoa*. All three species mentioned here infested the CIAT farm, resulting in a 20% yield loss when the mite attack occurred from the 5th to the 7th month of plant growth.

The CIAT germ plasm has a low resistance level to *Tetranychus* and moderate resistance levels to *Mononychellus* and *Oligonychus*.

There are several effective biological control agents for suppressing mite populations.

Control with Monocrotophos (Asodrin),

Galecron (Fundal), and other organophosphates at commercial doses is effective.

### Cassava Hornworm

The cassava hornworm *Erinnyis ello* is a most serious cassava pest in the Americas. High populations of hornworm larvae can rapidly defoliate large cassava plantations. Defoliation during the initial months of plant growth can kill plants and cause yield losses. The ash coloured, nocturnal females deposit their large, light green eggs on the upper surface of cassava leaves. The larvae are polymorphic and colour varies: yellow, green, black, dark gray, and tan are common. Fifth instar larvae may reach 10–12 cm in about 12 days, and migrate to the soil where they form a chestnut brown, black-lined pupa. The adult moth emerges in about 2 weeks. Outbreaks generally occur after the beginning of the rainy season, but are erratic and may be absent for years.

A biological control program is an effective means of hornworm control. Egg parasitism by *Trichogramma* sp. can effectively reduce populations. The paper wasp (*Polistes* sp.) is an important larval predator and *Apanteles* sp. (Hymenoptera) is a larval parasite. Effective control with the bacterial disease *Bacillus thuringiensis* has been obtained.

Dipterex is effective against young larvae but the use of pesticides should be avoided because it interrupts the biological control system.

### Cassava Shootfly

Shootfly (*Silba pendula*, *Carpolonchacae chalybea*) damage occurs throughout most of the Americas. Loss of yield is not yet known, but artificial shoot removal (up to 100% at periodic intervals) to simulate shootfly attack, did not affect yield.

The dark metallic blue adult shootfly oviposits between the unexpanded leaves in the growing points. The young larvae tunnel in the soft tissue and eventually kill the growing point. Several whitish larvae may be found in the affected growing point accompanied by a white to brown exudate. The mortality of the growing point retards growth of young plants and causes side buds to germinate, which may also be attacked. Younger plants are more susceptible to attack and most outbreaks occur in the beginning of the rainy season. Planting dates can be adjusted so that the younger

growing stage is passed during low shootfly populations. Larvae are difficult to control. Systemic organophosphate such as Basudin (diazinon), Diostop (dimetoate), Azodrin and Bidrin (dicrotophos) at commercial doses are recommended only for large populations.

### Whiteflies

Numerous species of whiteflies (*Bemisia tuberculata*, *B. tabaci*, *Aleurotrachelus* sp., *Trialeurodes variabilis* and *Aleurothrixus* sp.) attack cassava. No direct damage due to feeding is known but high populations may cause mottling, yellowing, and drying of the leaves. Whiteflies can be detected by provoking adults into flight or by observing the pupa and nymphs on the undersides of the leaves. A black sooty mold fungus is often found in association with whitefly attack. High populations are usually associated with the rainy season.

The whitefly *Bemisia tabaci* is a vector of the cassava mosaic disease which causes yield losses in Africa and Asia. This disease is not found in the Americas.

Varietal evaluation for resistance to the *Aleurotrachelus* sp., found in high populations in Colombia, shows moderate resistance for varieties CMC-72 and CMC-57.

Control of whiteflies, if needed, may be achieved with Roxion, Diostop, Metasyptox, and Dimecron.

### Grasshoppers

Grasshoppers have been identified as a pest on cassava only in Africa. There are two principal species; *Zonocerus elegans*, the elegant grasshopper, and *Z. variegatus*, the variegated grasshopper.

Both species cause damage in the dry season when their alternate hosts are reduced. In Africa heavy defoliation and stripping of the bark have resulted in yield losses up to 60%.

Grasshoppers can be controlled by the insecticides Gamalin 20 and Temitrothion.

### Cassava Lacebug

Yield losses due to lacebug (*Vatiga manihotae*) are not known, but considerable foliage damage can occur. The whitish nymphs and gray adults (3 mm) can be found in great numbers on the leaf underside. Damaged leaves show yellow spots which eventually turn to reddish brown, resembling mite damage.

### Leafcutter Ants

Several species (*Atta* sp. and *Acromyrmex* sp.) have been reported rapidly defoliating cassava when large numbers of worker ants move into a crop. A semi-circular leaf cut is made and carried off to the nest. During severe attack the buds may also be removed. Attacks frequently occur during the early months of the crop. The effect of this damage on yield is not known.

Insecticides are the most effective means of control. Nests can be destroyed by fumigation with carbonbisulfide, smoke of sulfur or arsenates. Good results will be obtained by applying Aldrin as a powder or in solution in or around the nest. Granular mirex baits applied along the ant trails will be carried into the nest by the ants and will give effective control.

### Gallmidges

Several species of gallmidges (*Cecidomyiidae*, *Iatrophobia* sp.) have been reported on cassava. These fragile flies oviposit on the leaf undersurface and the emerging larvae cause abnormal cell growth in the leaf and gall formation. Leaf galls on the uppersurface are yellow-green to red and when opened, show a cylindrical tunnel with the larvae inside. Gallmidges may retard growth of young plants but are considered of little economic importance and generally do not require control. Destruction of affected leaves at weekly intervals is recommended to reduce populations.

### Insects Attacking Mature or Green Stems

Approximately 35 species of stemborers have been identified feeding on and damaging stems and branches of the cassava plant. Most stemborers are the larval stage of coleoptera (*Coelosternus* spp., *Lagochirus* sp.), but some lepidopterous and hymenopterous stemborers are also reported. They generally cause sporadic or localized damage.

Larvae vary in size (up to 30 mm long) and shape depending on the species. Larvae are usually white to yellow to tan and tunnel through the aerial parts of the plants. Stems and branches may break or be reduced to sawdust. During dry periods, under heavy infestation, defoliation and death can occur. Frass

and exudate from the stemwood ejected from burrows by larval feeding can be found on infested branches or on the ground. Pesticide control appears impractical since adults are difficult to kill and larvae feed within plant stems. Populations can be reduced by removing infested plant parts and burning.

### Cassava Fruitfly

The cassava fruitfly (*Anastrepha pickeli*, *A. manihoti*) has recently been identified as a pest on cassava. It frequently attacks the cassava fruit and causes economic losses.

It attacks the stem about 10–20 cm below the apex, making a small entrance/exit hole. The yellow to tan female inserts the egg in the stem tissue and after hatching the white to yellow larvae bore into and down through the pith region of the stem.

A bacterial pathogen is often found in association with the larvae and this can cause severe rotting of stem tissue. Often a white exudate is found flowing from the larval tunnel. Severe attacks may cause collapse of the growing points, growth retardation, proliferation of lateral buds, and finally death of the plant.

The extent of crop losses due to this secondary rotting is not known but younger plants (2–5 months) are more susceptible to damage.

The use of attractants or poison baits as controls appears promising. A Hymenoptera parasite (*Opius* sp.) has been identified. The insecticide Lebaycid (Fenthion) gives good control of the larvae in the stem.

### Scale Insects

Several species of scales (*Aonidomytilus albus*, *Saissetia* spp.) attack cassava stems. Except for localized incidents they do not appear to cause any significant reduction in yield.

In severe attacks leaves may yellow and drop, the plants are stunted, and stems can dehydrate causing plant death. The greatest damage appears to be the loss of planting material. When heavily infested cuttings are planted germination is greatly reduced and roots will be poorly developed and unpalatable. The adult scale of *A. albus* is mussel-shaped and covered with a white waxy secretion. It attacks the branches, especially in the dry season, thus aggravating drought stress.

The most effective means of control is through the use of healthy planting material, and cutting and burning infested plants. Chem-

ical control on growing plants with *Metasystox* (0.1%) and *Malathion* (0.1%) is effective.

### Mealybugs

Mealybug (*Phenacoccus gossypii*) damage has recently been reported from Brazil, Colombia, and parts of Africa, but effect on yield is not known.

High populations of the insect give a cottony appearance to the green portion of the stem and on the leaf undersurfaces. Leaves will turn yellow and dry and stems and buds may also be killed.

### Conclusion

Insects and mites are a limiting factor in cassava production. There is an obvious need for an effective integrated pest management and disease control program, based on sound principles and utilizing the adaptability of cassava. As well, strict quarantine measures should be adopted to restrict the spread of insects into areas where they are not now present.

### Crop Adaptability

- (1) Cassava is a long-season crop; the continual use of pesticides is impractical.
- (2) Few if any insects will actually kill the plant.
- (3) The cassava plant has the ability to recuperate from insect damage.
- (4) The cassava plant can lose foliage without decreasing yield: A high economic threshold.

### Basic Principles of an Integrated Control System

- (1) Cassava is ideally suited to a biological control program.
- (2) High levels of pest resistance are not needed and resistance to some pests already exists.
- (3) It is necessary to understand the insect-plant-environment interaction. Rainfall and age of plant appear to be key factors.
- (4) Cultural practices (selection of planting material, crop rotation, etc.) can reduce pest incidence.
- (5) The intelligent use of insecticides.
- (6) The indiscriminate use of pesticides will interrupt biological control programs.

**Pest Management Program**

Thrips	Varietal resistance	Whiteflies	Varietal resistance
Hornworm	Biological control	Shootflies	Attractants
Mites	Varietal resistance		Cultural practices
	Biological control		Varietal resistance
Fruitflies	Cultural practices	Stemborers	Cultural practices
	Attractants	Mealybugs	Varietal resistance
	Varietal resistance		Biological control
Whitegrubs and cutworms	Microbial control	Scales	Biological control
	Poison baits		
	Cultural practices		
	Soil insecticides		

**Population Dynamics of the Green Cassava Mite and its Predator *Oligota***

Z. M. Nyiira<sup>1</sup>

The green cassava mite, *Mononychellus tanajoa* (Bondar) (Acarina: Tetranychidae), also known as the cassava leaf mite, is a fairly new pest in Africa. Its potential threat to cassava production in Africa has attracted serious investigations into its biology, ecology, and possible control. Initial infestations of this mite start in sheltered places, along the midribs and veins of cassava leaves.

Denser populations are recorded during dry spells and more are found in the lower half of the leaf. The ratio of active mites, eggs, males, and females in the apical and basal halves of the leaf are discussed. Cassava plants between 3 and 10 months old were more densely infested than the younger and older plants. Some varieties of cassava supported fewer mites than others suggesting a degree of resistance. Reduction in the number of mites was associated more with absence of leaves than weather conditions, although rain and possibly relative humidity had negative effects on population buildup of the mite.

The Staphylinidae *Oligota* was the dominant and widespread predator. It appeared in sufficient numbers and at the same time as the green cassava mite. The population fell sharply when the host population started diminishing.

The results point out the potential of varietal resistance in cassava and biological control as possible effective considerations in integrated control of *M. tanajoa*.

The green cassava mite *Mononychellus tanajoa* is a fairly new pest of cassava in Africa. Its potential threat to cassava production has attracted much attention because cassava is an important staple in Africa, where 36% of the world total is produced.

Although the green cassava mite was recorded as a major cassava pest in Brazil in 1921 (Bondar 1938), its low status did not demand serious investigation until its discovery in 1971 in Uganda (Nyiira 1972). Since then, detailed studies have been done (Bennett and Yaseen 1975; Nyiira 1975a).

The structure of the population (dispersion) of the green cassava mite on cassava in the neotropics was described by Bennett and Yaseen (1975). They discussed the influence of age of the plant, its physiological condition, and environmental factors on levels of infestation and damage.

Nyiira (1972, 1973) showed that heavy infestations and damage to cassava in Uganda occurred during the hot dry spells. This was later accompanied by premature leaf fall and sometimes tip die-off. Major damage was suppressed by the cool rainy season. Similar observations in Brazil were reported by Bondar (1938) and by Da Costa (1973). Such seasonal fluctuations of the mite population were

<sup>1</sup>Department of Agriculture, Kawanda Research Station, P.O. Box 7065, Kampala, Uganda.

**Pest Management Program**

Thrips	Varietal resistance	Whiteflies	Varietal resistance
Hornworm	Biological control	Shootflies	Attractants
Mites	Varietal resistance		Cultural practices
	Biological control		Varietal resistance
Fruitflies	Cultural practices	Stemborers	Cultural practices
	Attractants	Mealybugs	Varietal resistance
	Varietal resistance		Biological control
Whitegrubs and cutworms	Microbial control	Scales	Biological control
	Poison baits		
	Cultural practices		
	Soil insecticides		

**Population Dynamics of the Green Cassava Mite and its Predator *Oligota***

Z. M. Nyiira<sup>1</sup>

The green cassava mite, *Mononychellus tanajoa* (Bondar) (Acarina: Tetranychidae), also known as the cassava leaf mite, is a fairly new pest in Africa. Its potential threat to cassava production in Africa has attracted serious investigations into its biology, ecology, and possible control. Initial infestations of this mite start in sheltered places, along the midribs and veins of cassava leaves.

Denser populations are recorded during dry spells and more are found in the lower half of the leaf. The ratio of active mites, eggs, males, and females in the apical and basal halves of the leaf are discussed. Cassava plants between 3 and 10 months old were more densely infested than the younger and older plants. Some varieties of cassava supported fewer mites than others suggesting a degree of resistance. Reduction in the number of mites was associated more with absence of leaves than weather conditions, although rain and possibly relative humidity had negative effects on population buildup of the mite.

The Staphylinidae *Oligota* was the dominant and widespread predator. It appeared in sufficient numbers and at the same time as the green cassava mite. The population fell sharply when the host population started diminishing.

The results point out the potential of varietal resistance in cassava and biological control as possible effective considerations in integrated control of *M. tanajoa*.

The green cassava mite *Mononychellus tanajoa* is a fairly new pest of cassava in Africa. Its potential threat to cassava production has attracted much attention because cassava is an important staple in Africa, where 36% of the world total is produced.

Although the green cassava mite was recorded as a major cassava pest in Brazil in 1921 (Bondar 1938), its low status did not demand serious investigation until its discovery in 1971 in Uganda (Nyiira 1972). Since then, detailed studies have been done (Bennett and Yaseen 1975; Nyiira 1975a).

The structure of the population (dispersion) of the green cassava mite on cassava in the neotropics was described by Bennett and Yaseen (1975). They discussed the influence of age of the plant, its physiological condition, and environmental factors on levels of infestation and damage.

Nyiira (1972, 1973) showed that heavy infestations and damage to cassava in Uganda occurred during the hot dry spells. This was later accompanied by premature leaf fall and sometimes tip die-off. Major damage was suppressed by the cool rainy season. Similar observations in Brazil were reported by Bondar (1938) and by Da Costa (1973). Such seasonal fluctuations of the mite population were

<sup>1</sup>Department of Agriculture, Kawanda Research Station, P.O. Box 7065, Kampala, Uganda.

Table 1. Mites recorded on 10 leaves per sample at low, medium, and heavy infestation levels.

	Fifth leaf			Seventh leaf		
	Adults	Nymphs	Eggs	Adults	Nymphs	Eggs
Apical half						
Low	41	138	959	87	274	1224
Medium	209	371	2944	107	460	1617
Heavy	1021	3994	14194	1124	5960	11279
Basal half						
Low	258	537	4074	364	978	5269
Medium	452	808	10535	376	949	6569
Heavy	1360	5642	22646	1348	9322	15882

probably due to factors such as the condition of food and availability of nutrients. The weather may have had some influence as well.

A similar population trend was observed among its predators, particularly *Oligota* species. *Oligota* is the most common and dominant predator of the green cassava mite in Uganda and Trinidad (according to Bennett and Yaseen 1975). The population of density-dependent predators tends to decline as numbers of their prey decrease and vice versa.

Therefore, the population dynamics of both *M. tanajoa* and its predator *Oligota* were studied with the practical objective of suppressing the green cassava mite in Uganda.

## Materials and Methods

The effect of plant age on the population of mites was studied by counting the mites on fifth leaves of plants of different ages. Leaves were placed in jars, labelled, and placed in styrene boxes, and brought to the laboratory. The leaves were placed on ice blocks on the stage of the binocular with the dorsal side of the leaf facing the eyepiece, and the mites were counted. The mites that got stuck in the jars were washed into petri dishes using 50% alcohol, counted, and the count was added to the respective sample counts. Counts of mite eggs were carried out in the same way. The results were computed as means of total mite counts from 60 leaves per locality per age-group.

Assessment of the effect of age of foliage on mite population was done by counting mites on leaves tagged at the start of their development (i.e. from the time the leaf stalks became

visible and when such stalks could conveniently be tagged). Assessment of the population fluctuation of mites was done on fifth and seventh leaves using similar collection and counting techniques.

To study interleaf distribution and abundance of mites, weekly samples of first and subsequent odd-numbered leaves up to eleventh were taken. Five leaves were sampled per variety per week for 21 weeks.

Assessment of the population of the predator was done between October and December 1972. It was done by direct counts of predators from cassava leaves in the field. The leaves were collected, labelled, and the mites counted under a binocular microscope. All leaf index expressions were counted from the apical end.

## Results

### Ecological Habitat

At low densities, the green cassava mite prefers to inhabit areas along the midrib and the veins of cassava leaflets. Colonies generally start in sheltered areas on the leaves either on folds or at the base of the leaves. No webs are formed. A higher density of mites per leaf results in a more uniform distribution of the egg deposition and the active mite stages. There was generally a higher number of mites and their eggs in the lower half of the leaf. The number of active mites and their eggs on the leaves is presented in Table 1. When the ratio of adult mites and their stages and males and females in the apical half was compared with similar components in the basal half during the various levels of infestations, the results revealed higher basal half ratios at low in-

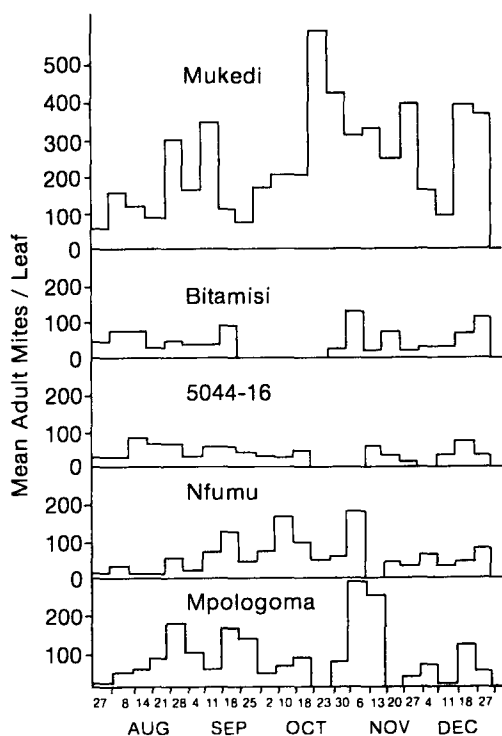

Fig. 1. Mean number of adult mites per leaf (1972).

festation and mean ratio of 1:2 during heavy infestation.

**Effect of Plant Age**

*M. tanajoa* almost exclusively feed on the undersurface of cassava leaves. However, infestation was recorded on flower stalks and young green seed. All age categories were attacked. The density of mite infestation on individual plants varied greatly. Newly germinated 10-week-old plants had insignificant numbers of mites compared to plants between 3 and 6 months. Denser infestation was recorded on plants between 6 and 9 months. Plants 9–12 and 12–15 months old had few mites.

In all age categories, a higher number of mites was recorded on either top leaves in the very young plants or leaves 5–8 in the older plants.

**Effect of Foliage Condition**

The results of investigations of the effect of

foliage condition in three varieties of cassava on mite stages revealed that there were significantly fewer active mites and their eggs on the very young and the very old leaves ( $p < 0.1\%$ ). The maximum density of eggs was recorded on 3-week-old leaves in Mukedi (985) and Mpologoma (459) varieties, whereas in Bitamisi, egg densities were high on leaves 10–21 days old (219–225). The population of active stages of the mite was most dense on leaves 12–21 days old in the two varieties (332 on Mukedi and 123 on Mpologoma).

**Fluctuation Trends**

Between August and December 1972 the weather and crop conditions were optimal for severe infestations of cassava by *M. tanajoa* in Uganda. There were more mites per leaf during September and the last half of October and first quarter of November (Fig. 1). Lower mite densities were associated more with absence of leaves on plants than with presence or absence of rain. For instance during mid August 1972 in Uganda, there was a lot of rain and low mite densities. However, heavy rain in October of the same year corresponded with high mite population on two cassava varieties (Bitamisi and Nfumu) although it reduced the mite population on Mukedi. The trend of mite egg density followed closely that of adult mites.

Nyiira (1975b) discussed the influence of physical factors on the biology and ecology of *M. tanajoa*, suggesting that factors such as relative humidity and temperature could negatively affect the reproduction rate of the mite. He further observed that migration and dispersal are partly triggered by high population density. Therefore, the reproduction rate which is influenced by the physical condition, would also partly influence the commencement and rate of dispersal. It would also influence distribution of the mite within and outside a unit. Biology of the mites as well as meteorological factors are, therefore, useful considerations in the ecological analysis of green cassava mite populations.

Rate of oviposit by *M. tanajoa* was higher at relative humidities between 50 and 70% (maximum 4.7 eggs per female per day at 60%). Most eggs were laid at 32 °C, and the rate was 3.8 eggs/female per day. Development of instars at different relative humidity levels was slightly different from that recorded

Table 2. Population of *Oligota* predators and corresponding host population on cassava during October through December 1972 at Kawanda Research Station.

Date sampled	Mites/Leaf		Predators/50 leaves		Infestation status
	Eggs	Adults and nymphs	Predators/50 leaves		
			Larvae	Adults	
13 Oct	1502	1040	0	47	Heavy
20 Oct	697	272	0	22	Heavy
27 Oct	1824	696	0	7	Heavy
3 Nov	688	238	0	24	Heavy
10 Nov	2126	601	3	20	Heavy
23 Nov	949	400	0	43	V. heavy
29 Nov	431	157	2	22	V. heavy
8 Dec	2190	422	2	21	V. heavy
14 Dec	530	349	0	4	V. heavy
22 Dec	1027	424	0	6	V. heavy
28 Dec	1162	390	0	2	V. heavy
Total	13126	4989	7	218	
Mean	1193	454	0.6	20	

in a free laboratory environment. A duration of 9 days was recorded from commencement of larval to end of deutonymphal periods at relative humidities of 50–70% compared to 10–11 days at 20–40% and 11–13 days at 80–100%. The green cassava mite was capable of multiplying 70 times in a generation lasting a mean of 17 days, at an intrinsic rate of natural increase of 0.25 mite per female per day.

### *Oligota* Predator Population

The results of a study of the seasonal abundance and correlation with host density are presented in Table 2. During scarcity of host mites, *Oligota* disappeared. The predator was more abundant on leaves 5–8 counting from the apical end. This high density of the predator coincided with the higher concentration of host mites on these leaves. This correlation was considered favourable and sufficiently effective particularly during the dry season when the population of the host mite was high. Ninety-five percent of *Oligota* recorded were adults. No pupae were recorded on leaves, although some were found in debris and the soil surface.

### Discussion

The green cassava mite probably chooses sheltered places as protection against harsh environment and excessive light. However, as the number of mites per leaf increases, they in-

habit the overall area of the leaf. The ratio of the number of mites and their stages and that of the different sexes in the apical half to that of similar components in the basal half decreases from 1:4 at low infestation to 1:2 or 1:1 at high infestation. This implies that at low infestation levels there is a tendency of mites to concentrate more in the sheltered places at the base of the leaf. The mites get dispersed as the population on the unit leaf increases. The dispersion might also be induced by depletion of food and nutrient at the initial point of infestation on the leaf.

The density of the mite infestation on plants of different ages varies greatly. The initial evidence is, however, that very young plants and very old plants do not harbour a high density of mites. Plants between 12 and 40 weeks of age are densely infested with active mite stages and their eggs. This was observed in other varieties (Nyiira 1975a), where, after 36–40 weeks the population of *M. tanajoa* was reduced so low that economic control measures were not desirable.

Aging of cassava leaves has a varied effect on population density of *M. tanajoa*. The population builds up until leaves are 35 days old, when the number of mites on them falls sharply probably due to depletion of nutrients and overpopulation. The tendency is for the mites to migrate within the plant onto the younger leaves or from heavily infested plants to less infested ones to form new colonies. The

foliage condition is, therefore, a critical determinant of rate of migration and dispersal.

Many factors are involved in regulating mite populations. However, the data presented in Fig. 1 suggest that different varieties of cassava support different population densities even when other conditions are similar. This variation in the intensity of infestation and, therefore damage, suggests that certain varieties are preferred. This preference would suggest breeding cassava varieties that are resistant or tolerant to the green cassava mite. We favour breeding fast-maturing varieties that are resistant/tolerant to *M. tanajoa* as the most effective control measure (Nyiira 1975c).

*Oligota* species in Uganda appear in synchrony with *M. tanajoa*. Table 2 shows, however, that during heavy infestation by the host mite when the population of the latter is about to start diminishing, the population of the predator falls rapidly. This allows a rapid buildup of the host mite to migrate to fresh leaves before the predator population builds up again. However, the reappearance of *Oligota*, and the combined relative effectiveness of other predators of the host mite, appear to keep down mite populations. An integrated program utilizing fast-maturing resistant/tolerant varieties backed by a viable program of biological control was suggested by Nyiira (1975a). Bennett (1975) and Bennett and Yaseen (1975) obtained useful data on correlations of *Oligota* and phytoseiid predatory mites with *M. tanajoa* populations in Trinidad. They have reported variations in the abundance of the predators. Their results probably explain the

total effect of predators on the green cassava mite, an effect not otherwise explained when individual predators are considered.

Bondar, G. *Notas Entomologicas de Bahia II*. Rev. Entomol. Brazil. 9, 1938, 441-449.

Bennett, F. D. *Quarterly report for July-Sept.* Commonwealth Institute of Biological Control, West Indian Station, Gordon Street, Trinidad, 1975.

Bennett F. D., and Yaseen, M. *Investigation on the cassava mite Mononychellus (Bondar) and its natural enemies in the Neotropics*. Report for April 1974-March 1975. CIBC, Gordon Street, Trinidad, 1975.

Da Costa, J. M. *Resultados experimentos obtidos no control de acaros da mandioca, "Mononychellus tanajoa" (Bondar, 1938) de Agricultura*. Brascan Nordeste. Serie Pesquisa, 1973.

Nyiira, Z. M. *Report of investigation of cassava mite, Mononychellus tanajoa (Bondar)*. Kawanda Research Station, Kampala, Uganda, 1972

*Bioecological studies on the cassava mite, Mononychellus tanajoa (Bondar) (Acarina: Tetranychidae)*. Proc. 3rd International Symposium on Tropical Root Crops, Ibadan, Nigeria. Dec. 1973.

*Biology, distribution, and ecology in Uganda of the green cassava mite, Mononychellus tanajoa (Bondar) (Acarina: Tetranychidae)*. PhD thesis, 1975a, 314p.

*Cassava mite and meteorology*. Proc. U. Soc. 1975b (in press).

*Advances in research on the economic significance of the green cassava mite (Mononychellus tanajoa) in Uganda*. In The International Exchange and Testing of Cassava Germ Plasm in Africa. IDRC-063e, 1975c, 27-29.

## Distribution, Biology, and Population Dynamics of the Green Cassava Mite in the Neotropics

M. Yaseen and F. D. Bennett<sup>1</sup>

Investigations on the biology and ecology of the green cassava mite *Mononychellus tanajoa* and its natural enemies, as well as those of other cassava mites, to evaluate the latter for trial in Africa have been conducted in the Neotropics since April 1974 by the Commonwealth Institute of Biological Control, Trinidad. In Trinidad, densities of *M. tanajoa* are closely related to rainfall; dry periods are conducive to the development of high mite populations. The age and physiological condition of the host plant also greatly influence mite densities. Mite dispersal is influenced by wind. Regular observations on several cassava varieties during 1975 did not indicate any of these to be resistant to mite attack.

<sup>1</sup>Commonwealth Institute of Biological Control, Gordon Street, Curepe, Trinidad.

foliage condition is, therefore, a critical determinant of rate of migration and dispersal.

Many factors are involved in regulating mite populations. However, the data presented in Fig. 1 suggest that different varieties of cassava support different population densities even when other conditions are similar. This variation in the intensity of infestation and, therefore damage, suggests that certain varieties are preferred. This preference would suggest breeding cassava varieties that are resistant or tolerant to the green cassava mite. We favour breeding fast-maturing varieties that are resistant/tolerant to *M. tanajoa* as the most effective control measure (Nyiira 1975c).

*Oligota* species in Uganda appear in synchrony with *M. tanajoa*. Table 2 shows, however, that during heavy infestation by the host mite when the population of the latter is about to start diminishing, the population of the predator falls rapidly. This allows a rapid buildup of the host mite to migrate to fresh leaves before the predator population builds up again. However, the reappearance of *Oligota*, and the combined relative effectiveness of other predators of the host mite, appear to keep down mite populations. An integrated program utilizing fast-maturing resistant/tolerant varieties backed by a viable program of biological control was suggested by Nyiira (1975a). Bennett (1975) and Bennett and Yaseen (1975) obtained useful data on correlations of *Oligota* and phytoseiid predatory mites with *M. tanajoa* populations in Trinidad. They have reported variations in the abundance of the predators. Their results probably explain the

total effect of predators on the green cassava mite, an effect not otherwise explained when individual predators are considered.

Bondar, G. *Notas Entomologicas de Bahia II*. Rev. Entomol. Brazil. 9, 1938, 441-449.

Bennett, F. D. *Quarterly report for July-Sept.* Commonwealth Institute of Biological Control, West Indian Station, Gordon Street, Trinidad, 1975.

Bennett F. D., and Yaseen, M. *Investigation on the cassava mite Mononychellus (Bondar) and its natural enemies in the Neotropics*. Report for April 1974-March 1975. CIBC, Gordon Street, Trinidad, 1975.

Da Costa, J. M. *Resultados experiments obtidos no control de acaros da mandioca, "Mononychellus tanajoa" (Bondar, 1938) de Agricultura*. Brascan Nordeste. Serie Pesquisa, 1973.

Nyiira, Z. M. *Report of investigation of cassava mite, Mononychellus tanajoa (Bondar)*. Kawanda Research Station, Kampala, Uganda, 1972

*Bioecological studies on the cassava mite, Mononychellus tanajoa (Bondar) (Acarina: Tetranychidae)*. Proc. 3rd International Symposium on Tropical Root Crops, Ibadan, Nigeria. Dec. 1973.

*Biology, distribution, and ecology in Uganda of the green cassava mite, Mononychellus tanajoa (Bondar) (Acarina: Tetranychidae)*. PhD thesis, 1975a, 314p.

*Cassava mite and meteorology*. Proc. U. Soc. 1975b (in press).

*Advances in research on the economic significance of the green cassava mite (Mononychellus tanajoa) in Uganda*. In The International Exchange and Testing of Cassava Germ Plasm in Africa. IDRC-063e, 1975c, 27-29.

## Distribution, Biology, and Population Dynamics of the Green Cassava Mite in the Neotropics

M. Yaseen and F. D. Bennett<sup>1</sup>

Investigations on the biology and ecology of the green cassava mite *Mononychellus tanajoa* and its natural enemies, as well as those of other cassava mites, to evaluate the latter for trial in Africa have been conducted in the Neotropics since April 1974 by the Commonwealth Institute of Biological Control, Trinidad. In Trinidad, densities of *M. tanajoa* are closely related to rainfall; dry periods are conducive to the development of high mite populations. The age and physiological condition of the host plant also greatly influence mite densities. Mite dispersal is influenced by wind. Regular observations on several cassava varieties during 1975 did not indicate any of these to be resistant to mite attack.

<sup>1</sup>Commonwealth Institute of Biological Control, Gordon Street, Curepe, Trinidad.

Predators play a significant role in regulating population densities of the mite. Of the several predators recorded, *Oligota minuta*, the dominant predator, and *Typhlodromalus limonicus* and *T. rapax*, two important predaceous mites, merit introduction against *M. tanajoa* in Africa.

The Neotropical green cassava mite *Monychellus tanajoa* was reported recently from Uganda (Nyiira 1972). The mite spread rapidly and is already causing serious damage in several parts of the Ethiopian region of Africa. Heavy infestations result in retarded plant growth and leaf shedding (Lyons 1973). Because chemical control under African conditions is not practical, other measures including biological control are being studied.

As *M. tanajoa* is not considered a serious pest in the Neotropics very little information is available about the mite and its predators. Investigations on the biology and ecology of the mite and its natural enemies, as well as those of other cassava mites, to evaluate the latter for trial in Africa were initiated at this laboratory in April 1974. The results obtained to date are presented here.

## Investigations and Results

### Distribution of *M. tanajoa*

The mite occurs in Brazil (Bondar 1938) and Paraguay (Aranda and Flechtmann 1971), and is now widespread in Trinidad and Guyana. It is also abundant in Colombia and probably occurs in Surinam and Venezuela.

### Other Mites

Surveys have been carried out for cassava mites and their natural enemies in several areas in Central and South America and the Caribbean, and several other tetranychids infesting cassava were encountered. While special visits were made to survey for cassava mites in Colombia, Mexico, Panama, and Peru, other records were obtained from Antigua, the Bahamas, Barbados, Guatemala, Jamaica, Montserrat, Nicaragua, St. Kitts, and Surinam in connection with other work. Records of *M. tanajoa* and other tetranychids on cassava encountered during the surveys are given in Table 1.

Of the three tetranychids attacking cassava in Trinidad, *M. tanajoa* belongs to the *caribbeanae* group characterized by Paschoal (1971), and can be easily recognized. Both *T. tumidus* and *T. urticae* females are carmine

but the former is easily separated by the well-developed mediadorsal spur on the empodium which is tiny or absent from *T. urticae* (Pritchard and Baker 1955). *T. tumidus* is usually a greenhouse pest while *T. urticae* attacks senescent leaves with depleted nutrients. *M. tanajoa* is not common on such plants.

### Biology

The biology of *M. tanajoa* was investigated in the laboratory (temperature  $26.8 \pm 2.2$  °C and relative humidity of 82% in the morning to 55% in the afternoon). The preoviposition period lasted 1–2 days. The duration of the egg, larval, protonymphal and deutonymphal stages were 3–4, 1–2, 1–2 and 2–3 days, respectively. Each active stage was followed by a quiescent stage lasting less than a day and the total egg to adult period was 11–13 days. The males which mature first remain near the female telcochrysalis ready to mate with the emerging females. Females laid 21–65 (avg  $38.5 \pm 15.8$ ) eggs during 8–14 days; they lived up to 18 days.

Under field conditions eggs are laid singly on the sides of the midrib or other veins or in concavities on the lower surface of the leaf. Most of the eggs are laid on the basal half of the leaf.

### Population Studies

Regular observations from April 1974 to date have shown that densities of *M. tanajoa* are closely related to the pattern of rainfall. In Trinidad the average daily temperatures do not fluctuate greatly during the year. The annual rainfall varies from 2100 to 2500 mm. The main rainy season extends from the end of May or early June to December or mid January; about 80% of the annual precipitation occurs from middle of July to December despite a comparatively dry period of 4–5 weeks in September–October. The relative humidity varies from about 80% in the morning to about 55% in the afternoon during the dry season and remains generally high, around 90%, during the wet season.

Data, based on weekly counts, indicate that dry periods are conducive to the development

Table 1. Tetranychids collected on cassava during surveys in 1974-75 (localities in parentheses).<sup>a</sup>

Tetranychids	Distribution
<i>Mononychellus (Eotetranychus) caribbeanae</i> (McGregor)	Barbados, Nicaragua (Carazo), Panama (Aquadulce), Peru (Chiclago), St. Kitts (Sandy Point) and Bahamas (Andros)
<i>M. mcgregori</i> (Flechtmann and Baker)	Colombia (Jamundi)
<i>M. tanajoa</i> (Bondar)	Brazil (State of Bahia), Colombia, Guyana (Georgetown), Paraguay and Trinidad
<i>Oligonychus peruvianus</i>	Colombia (Cauca Valley)
<i>Tetranychus cinnabarinus</i> (Boisduval)	Montserrat, W.I.
<i>T. tumidus</i> (Banks)	Mexico (Yucatan State) and Trinidad
<i>T. urticae</i> (Koch)	Colombia (Cauca Valley), Peru (La Molina and Mala) and Trinidad
<i>T. sp. probably urticae</i>	Colombia (Palmira) and Peru (Mala)
<i>Tetranychus sp.</i>	Bahamas (Andros Island), Mexico (Yucatan State) and Nicaragua (Granada)

<sup>a</sup>See Flechtmann and Baker (1970) and Jeppson et al. (1975) for additional distribution and host records.

of high mite populations. Mite populations showed upward trends in March-April and developed peak levels by the end of May or early June which persisted to the middle of July when they dropped suddenly with the onset of heavy rains. A minor peak developed during the short dry period in September-October. Weekly counts on 10 cassava varieties in an experimental plot during 1975 indicated that 56.1-66.5% of the mite population occurred in June-July during the major peak level and 9.0-29.7% in September-October during the short-lived minor peak. Sustained heavy rains in October were catastrophic. As *M. tanajoa* does not form a protective web all stages including the eggs were dislodged by sustained heavy rain and the mite was scarce throughout the remainder of the wet season.

The age and physiological condition of the host plant also influenced mite densities. Very young plants usually harboured few mites; the few newly flushed leaves not only provide only small surface areas but the nutrients are not fully synthesized. Similarly very old plants with depleted nutrients and retarded growth did not provide favourable conditions. Young vigorous plants about 4-8 months old, which produce new leaves early in the dry season, provide very favourable conditions for the development of heavy mite populations.

Most of the mites occur on the upper leaves of the plant, the largest numbers being on leaves 5-10; the top 3-4 newly flushed leaves

carry few mites. After the tenth leaf the numbers fall sharply apparently due to the depletion of nutrients.

Several tetranychids disperse under the influence of wind (van deVries et al. 1972). Female mites suspend themselves on silken threads and are carried away by wind currents. This activity usually occurs during the hot and comparatively calm periods between 9 and 10 AM and 3 and 4 PM when the wind speed is below 5 mph. In an experimental plot the mite dispersed over a distance of 200 m in the direction of the prevailing wind between 1 May and 23 July 1975.

Montaldo (1972) reported cassava varieties resistant to tetranychids in Venezuela. Also Nyiira (1972) noticed varying levels of *M. tanajoa* infestations and differing degrees of susceptibility related to cassava varieties in Uganda. Regular counts were made on four cassava varieties from May to September 1974 and, while different levels of infestations were noticed, the results were inconclusive because the plots of the different varieties were in different rainfall zones. In a special plot with 10 local varieties at Curepe weekly counts of mites from March 1975 to February 1976 indicated that none of these varieties was entirely resistant to mite attack. However, significant differences in mite densities on some varieties were recorded during the periods of peak populations. While variety Maracas Black Stick had the lowest levels during both the

Table 2. Predators of *M. tanajoa* and related cassava mites encountered during surveys in the neotropics, 1974-75.

Predator	Distribution
Phytoseiidae	
<i>Euseius hibisci</i> (Chant)	The Bahamas (Andros Island)
<i>Phytoseiulus macropilis</i> (Banks)	Peru (Mala)
<i>Typhlodromalus limonicus</i> (Garman and McGregor)	Colombia (Cali), Mexico (Oaxaca State) and Trinidad
<i>T. rapax</i> (DeLeon)	Colombia (Palmira) and Trinidad
Cecidomyiidae	
<i>Feltiella</i> sp.	The Bahamas and Montserrat
Unidentified	Barbados, St. Kitts, and Trinidad
<i>Feltia</i> sp.	Mexico (Tapachula-Chinapo)
Coccinellidae	
<i>Stethorus</i> sp.	Nicaragua, Trinidad, and Colombia
Staphylinidae	
<i>Oligota barbadorum</i> (Frank)	Barbados
<i>O. centralis</i> (Sharp)	Colombia, Mexico and Peru
<i>O. minuta</i> (Cam.)	Antigua, the Bahamas (New Providence and Andros Island), Colombia, Montserrat, Peru, and Trinidad
Thysanoptera	
Unidentified	Trinidad

major and the minor peak populations the other varieties were not very consistent.

### Natural Enemies

While spider mites are regularly attacked by predators they have no arthropod parasites. Predators belonging to the families Phytoseiidae, Cecidomyiidae, Coccinellidae, Staphylinidae, and a thysanopteran in association with cassava mites were encountered during surveys in the Neotropics (Table 2).

Both qualitative and quantitative data on the predators of cassava mites were obtained by regular sampling in several fields as well as in plots especially set up for this purpose in Trinidad. Elsewhere surveys were brief and qualitative data only were obtained.

*Oligota minuta* is the dominant predator of *M. tanajoa* in Trinidad. Eggs are deposited on the lower surface of the leaf. Eggs are laid amongst the mite infestations; only a few are laid next to the veins. Small larvae prefer host eggs but the second- and third-stage larvae which consume the most prey, as well as the adults, feed on eggs and all active stages of the host.

Fluctuations in populations of this staphylinid were correlated with those of the host. Regular counts from April 1974 to March 1976 showed that it was scarce or absent from

cassava when mite infestations are very low during July to late February. It appears in March when the mite commences to increase and it becomes abundant when host populations reach peak levels in May to July. The abundance is highly correlated with the mite densities on individual plants with the largest numbers occurring on heavily infested plants. The numbers of the predator also vary in relation to the infestation levels on leaves of individual trees; larger numbers were encountered on leaves 6-10, the largest numbers occurring on leaves 7 or 8 where adults and large nymphs of the mite are usually most abundant. Adults are usually more abundant on densely infested leaves in the early morning hours than during the hotter period between 10 AM and 5 PM.

Regular counts in experimental plots of cassava varieties in 1975 indicated differences in the predator population correlated more closely with host densities than with variety of cassava; larger numbers were encountered on the varieties Black Stick and Brown Stick which harboured higher mite populations than on variety Maracas Black Stick which had few mites. Black Stick had the highest mite density (158.9/leaf) and also the largest predator population in June. It showed a lower host density in July while on Brown Stick, which had comparatively fewer mites and fewer

staphylinids in June, an increase in mites occurred in July. This suggests that when abundant the staphylinid suppresses mite populations. During periods of scarcity of mites on cassava *O. minuta* migrates to plants infested with other spider mites.

The two phytoseiid mites *Typhlodromalus limonicus* and *T. rapax* are regularly associated with *M. tanajoa* on cassava in Trinidad. Eggs of both species are laid amongst the mites even when infestations are light. Adults and nymphs actively prey on the eggs and active stages of *M. tanajoa*; when not feeding they rest for long intervals concealed either along the mid-rib or on the petiole.

The phytoseiids are most abundant during the peak levels of the host mite population but they are seldom as abundant as *Oligota* and their intrinsic rate of increase appears to be lower than that of *M. tanajoa*.

The undetermined cecidomyiid appeared only during periods of peak mite densities and then only in negligible numbers. *M. tanajoa* does not seem to be its preferred host as larvae are more abundant on infestations of the carmine mite on other hosts. Larvae of the predatory thrips occasionally preyed on host eggs and the active stages of *M. tanajoa* but adults were seldom observed on cassava. The occurrence of *Stethorus* sp. was sporadic even during peak levels of *Mononychellus* which does not seem to be its regular prey.

### Effects of Pesticides

The effects of Galecron and Malathion were studied in a cassava plot at the Experimental Station of the University of the West Indies during June 1975 to January 1976. Initially the plot was treated with Galecron (2.2 g/gal). While the mite was suppressed initially after the treatment its resurgence was rapid and additional treatments were required every 3–4 weeks. In August this acaricide was replaced by Malathion but its effectiveness did not extend beyond 2 weeks and the plot was sprayed every 15–18 days to keep mite populations at a low level.

The mite populations in the untreated plot exhibited the normal pattern of seasonal incidence (2691 in June, 355 in November, 1077 in January) observed elsewhere and the predatory fauna persisted throughout the period. In the treated plots the frequency of sprays did not give the predators sufficient time to recover. While *Oligota* and also the cecidomyiid

predator appeared to a minor extent with the resurgence of the mite in June–August, *Typhlodromalus* spp. which were the main predators later in the season did not. Recovering from the effects of chemical pesticides, *M. tanajoa* builds up rapidly in the absence or scarcity of predators on the treated plants.

Predatory mites and *M. tanajoa* were suppressed by the pesticide applications but populations of the latter recovered and built up very rapidly before the former reinvaded the plants.

### Effects of Fertilizers

Since densities of mite populations are associated with nutrient levels, studies on the mite response on 10 cassava varieties in plots treated with NPK were initiated in January 1976. The results are still inconclusive but observations during January–March indicated that mite populations were higher in all treated plots than in the untreated check plot. Within the treated plots differences apparently related to both fertilizer treatment and variety. While on variety Black Stick higher populations occurred in the P treatment, the K treatments on varieties Fromogene and Tobago Special supported the highest populations. The trends on other varieties were not consistent: initially the P treatment on variety Around-the-world supported higher populations than those of N and K, whereas populations on the N treatments on varieties Dan, DanBlue, and Butter Stick were higher than on the other treatments. However, the K treatments for these three varieties later had the highest population. Similarly, the N treated plots of Brown Stick and Maracas Black Stick and the K treated plots of Butter Stick 133-2 supported the largest numbers in January, but in February–March populations were higher in the P treated plots. For variety Red Stick the largest populations occurred in the K treated plots in January but during February–March the N treated plots carried the heaviest infestations.

### Discussion and Conclusions

In Trinidad and probably in the rest of the Neotropics *M. tanajoa* for most of the year remains at very low population levels due to heavy rains. During dry periods it may reach epidemic proportions but predators play a significant role in regulating the population densities.

*O. minuta* is the dominant predator. It is adapted to prey on tetranychids and is known from mites from several hosts (Frank 1972). The species, being density-dependent, survives the periods of low-host density on cassava by moving on to other hosts.

Both *Typhlodromalus* spp. are in constant association with the host on cassava. They have good searching ability and are present whether the numbers of the hosts are high or low. *T. limonicus* survives the periods of host scarcity by feeding on pollen (McMurtry and Scriven 1965). Both the phytoseiid predators and *O. minuta* merit introduction against *M. tanaioa* in Africa.

Of the other predators, the staphylinids *Oligota barbadorum* and *O. centralis* and phytoseiids *Euseius hibisci* and *Phytoseiulus macropilus* need to be further evaluated.

Thanks are due to H. A. Denmark, Florida Department of Agriculture and Consumer Services, and C. H. W. Flechtmann, Universidad de São Paulo, Brazil, for the identification of mites. J. H. Frank, Florida Medical Entomology Laboratory, Vero Beach, Florida, identified *Oligota* spp. These investigations were financed by the International Development Research Centre, Canada.

Aranda, B. R. and Flechtmann, C. H. W. *A report on the Tetranychidae of Paraguay (Acarina)*. Proc. Ent. Soc. Wash. 73(1), 1971, 29-33.

Bondar, G. *Notas entomológicas da Bahia*. Rev. Ent. 9(304), 1938, 441-449.

Flechtmann, C. H. W., and Baker, E. W. *A preliminary report on the Tetranychidae (Acarina)*

*of Brazil*. Ann. Ent. Soc. Amer. 63(1), 1970, 156-163.

Frank, J. H. *The genus Oligota Mannerheim in the Caribbean region (Coleoptera:Staphylinidae)*. The Coleopterist Bull. 26(4), 1972, 125-146.

Jeppson, L. R., Keifer, H. H., and Baker, E. W. *Mites injurious to economic plants*. Berkeley and Los Angeles, 1975, 1-614.

Lyons, W. F. *A plant feeding mite Mononychellus tanajoa (Bondar) (Acarina:Tetranychidae) new to African continent threatens cassava (Manihot esculenta Crantz) in Uganda, East Africa*. PANS, 19(1), 1973, 36-37.

McMurtry, J. A., and Scriven, G. T. *Life history studies of Amblyseius limonicus with comparative studies on Amblyseius hibisci (Acarina:Phytoseiidae)*. Ann. Ent. Soc. Amer. 58, 1965, 106-222.

Montaldo, A. *La Yuca; trabajo sobre este cultivo, con especial referencia a Venezuela*. Maracay, Venezuela, Ministerio de Agricultura y cria. Oficina de Comunicaciones Agrícolas, 1972, 113p.

Nyiira, Z. M. *Report of investigations of cassava mite, Mononychellus tanajoa Bondar*. Kawanda Research Station, Kampala, Uganda, 1972.

Paschoal, A. D. *A review of the caribbeanae group (Acarina:Tetranychidae)*. Rev. Per. Entom. 14(1), 1971, 177-179.

Pritchard, A. E., and Baker, E. W. *A revision of the spider mite family Tetranychidae*. Mem. Pacific Coast Ent. Soc. 2, 1955, 1-472.

Van de Vries, M., McMurtry, J. A., and Huffaker, C. B. *Biology of Tetranychid mites and their natural enemies: A review. 3. Biology, ecology and pest status, and host-plant relations of Tetranychids*. Hilgardia, 41(13), 1972, 343-432.

## Susceptibility of Cassava Chips to *Araeceras fasciculatus*

K. S. Pillai<sup>1</sup>

Studies were made to ascertain the relative susceptibility of cassava chips made from different varieties to *A. fasciculatus*. The test insect was collected from the storage house and cultured in the laboratory on cassava chips. Ten cassava varieties H-165, H-226, H-1687, H-2304, H-38, H-3641, H-312, H-97, H-2059, and H-1310 were used. H-226 and H-2304 were the least susceptible.

Because raw cassava tubers cannot be stored indefinitely, the common practice is to slice the tubers and sun-dry them before storing. The slices (chips) are also parboiled, dried, and stored to enhance the keeping quality. The

sun-dried chips are more widely preferred for eating. Chips are attacked by more than a dozen storage pests, the most important one (*Araeceras fasciculatus*) causing great economic loss. It is commonly called the arecanut beetle as it was a specific pest of stored arecanuts (Ayyar 1940; Nair and Oommen 1969). *A. fasciculatus* eats a wide variety of foods and

<sup>1</sup>Central Tuber Crops Research Institute, Trivandrum, India.

*O. minuta* is the dominant predator. It is adapted to prey on tetranychids and is known from mites from several hosts (Frank 1972). The species, being density-dependent, survives the periods of low-host density on cassava by moving on to other hosts.

Both *Typhlodromalus* spp. are in constant association with the host on cassava. They have good searching ability and are present whether the numbers of the hosts are high or low. *T. limonicus* survives the periods of host scarcity by feeding on pollen (McMurtry and Scriven 1965). Both the phytoseiid predators and *O. minuta* merit introduction against *M. tanaioa* in Africa.

Of the other predators, the staphylinids *Oligota barbadorum* and *O. centralis* and phytoseiids *Euseius hibisci* and *Phytoseuilus macropilus* need to be further evaluated.

Thanks are due to H. A. Denmark, Florida Department of Agriculture and Consumer Services, and C. H. W. Flechtmann, Universidad de São Paulo, Brazil, for the identification of mites. J. H. Frank, Florida Medical Entomology Laboratory, Vero Beach, Florida, identified *Oligota* spp. These investigations were financed by the International Development Research Centre, Canada.

Aranda, B. R. and Flechtmann, C. H. W. *A report on the Tetranychidae of Paraguay (Acarina)*. Proc. Ent. Soc. Wash. 73(1), 1971, 29-33.

Bondar, G. *Notas entomológicas da Bahia*. Rev. Ent. 9(304), 1938, 441-449.

Flechtmann, C. H. W., and Baker, E. W. *A preliminary report on the Tetranychidae (Acarina)*

*of Brazil*. Ann. Ent. Soc. Amer. 63(1), 1970, 156-163.

Frank, J. H. *The genus Oligota Mannerheim in the Caribbean region (Coleoptera:Staphylinidae)*. The Coleopterist Bull. 26(4), 1972, 125-146.

Jeppson, L. R., Keifer, H. H., and Baker, E. W. *Mites injurious to economic plants*. Berkeley and Los Angeles, 1975, 1-614.

Lyons, W. F. *A plant feeding mite Mononychellus tanajoa (Bondar) (Acarina:Tetranychidae) new to African continent threatens cassava (Manihot esculenta Crantz) in Uganda, East Africa*. PANS, 19(1), 1973, 36-37.

McMurtry, J. A., and Scriven, G. T. *Life history studies of Amblyseius limonicus with comparative studies on Amblyseius hibisci (Acarina: Phytoseiidae)*. Ann. Ent. Soc. Amer. 58, 1965, 106-222.

Montaldo, A. *La Yuca; trabajo sobre este cultivo, con especial referencia a Venezuela*. Maracay, Venezuela, Ministerio de Agricultura y cria. Oficina de Comunicaciones Agrícolas, 1972, 113p.

Nyiira, Z. M. *Report of investigations of cassava mite, Mononychellus tanajoa Bondar*. Kawanda Research Station, Kampala, Uganda, 1972.

Paschoal, A. D. *A review of the caribbeanae group (Acarina:Tetranychidae)*. Rev. Per. Entom. 14(1), 1971, 177-179.

Pritchard, A. E., and Baker, E. W. *A revision of the spider mite family Tetranychidae*. Mem. Pacific Coast Ent. Soc. 2, 1955, 1-472.

Van de Vries, M., McMurtry, J. A., and Huffaker, C. B. *Biology of Tetranychid mites and their natural enemies: A review. 3. Biology, ecology and pest status, and host-plant relations of Tetranychids*. Hilgardia, 41(13), 1972, 343-432.

## Susceptibility of Cassava Chips to *Araeceras fasciculatus*

K. S. Pillai<sup>1</sup>

Studies were made to ascertain the relative susceptibility of cassava chips made from different varieties to *A. fasciculatus*. The test insect was collected from the storage house and cultured in the laboratory on cassava chips. Ten cassava varieties H-165, H-226, H-1687, H-2304, H-38, H-3641, H-312, H-97, H-2059, and H-1310 were used. H-226 and H-2304 were the least susceptible.

Because raw cassava tubers cannot be stored indefinitely, the common practice is to slice the tubers and sun-dry them before storing. The slices (chips) are also parboiled, dried, and stored to enhance the keeping quality. The

sun-dried chips are more widely preferred for eating. Chips are attacked by more than a dozen storage pests, the most important one (*Araeceras fasciculatus*) causing great economic loss. It is commonly called the arecanut beetle as it was a specific pest of stored arecanuts (Ayyar 1940; Nair and Oommen 1969). *A. fasciculatus* eats a wide variety of foods and

<sup>1</sup>Central Tuber Crops Research Institute, Trivandrum, India.

Table 1. The means of insect population and quantity of cassava chips damaged in different treatments (varieties).

Varieties	Mean population of test insect	Mean quantity of chips damaged (g)
H-226	39.3	154.3
H-1687	101.1	217.7
H-165	85.0	209.3
H-2304	64.0	147.0
H-38	88.3	209.0
H-3641	97.3	207.0
H-312	99.3	201.0
H-97	100.0	200.3
H-2059	90.0	194.7
H-1310	106.3	205.0

infests such crops as cassava, maize, pulses, ginger, and arecanut (Raghunath and Nair 1970). Though it is a serious pest of stored cassava chips, little work has so far been done on the extent of damage and the relative resistance/susceptibility of different cassava varieties. Raghunath and Nair (1970) reported that cassava is the preferred host material of the insect.

### Materials and Methods

Mass culture of *A. fasciculatus* on cassava was maintained in the laboratory from the inoculum obtained from the storehouse. Fresh sun-dried chips (250 g) of uniform size from each of the 10 hybrids were kept in thick polythene bags. Three identical samples were used in the experiment. Ten pairs of freshly emerged test insects were put into each bag for feeding and multiplication. The bags containing host material and test insects were dipped and kept in the laboratory for 45 days. The

bags were then opened, and the number of adult beetles and the quantity of chips powdered were recorded. The data collected were subjected to analysis of variance.

### Results and Discussion

The data presented in Table 1 record the mean number of adult insects (from 39.3 of H-226 to 106.3 of H-1310) obtained and also the mean quantity of cassava chips powdered or damaged in each variety (147 g of H-2304 to 217.7 g of H-1687) after 45 days. The quantity of chips damaged was usually directly proportional to the progeny increase in the test insects. The data indicate that H-226 and H-2304 are significantly superior to the other varieties in not promoting the population buildup of the pest.

There is also a significant difference between H-226 and H-2304 and H-226 has the highest resistance to this insect.

In quantity of chips damaged, all varieties except H-2304 and H-226 are susceptible and significantly inferior, but between these two there is no significant difference.

Thanks are due to Dr N. Hrishi, Director, Central Tuber Crops Research Institute, Trivandrum, for his kind help and for providing necessary facilities. Smt K. R. Lakshmi assisted in the statistical analysis of the data.

Ayyar, T. V. R. *Handbook of economic entomology for South India*. Govt. Press, Madras, 1940, 516.

Nair, M. R. G. K., and Oommen, C. N. *Insect pests of stored arecanut in Kerala*. J. Kir. Acad. Biol. 2(1), 1969, 14-21.

Raghunath, P., and Nair, M. R. G. K. *Host biology relations of Araeceras fasciculatus*. Agri. Res. J. Kerala, 8(1), 1970, 17-21.

## Utilization of Potatoes in the Tropics

N. R. Thompson, R. T. Wurster, and K. D. Sayre<sup>1</sup>

Research at the International Potato Center in Peru has demonstrated that excellent potato yields can be obtained under both intermediate- and low-elevation tropical environments. The potato clones that are well-adapted to these conditions mature quickly (65-90 days). This characteristic allows more flexibility to introduce the potato into current farm-

<sup>1</sup>On leave from Michigan State University, USA; Regional Research and Training, International Potato Center, Lima, Peru, and Department of Plant Physiology, International Potato Center, Lima, Peru, respectively.

Table 1. The means of insect population and quantity of cassava chips damaged in different treatments (varieties).

Varieties	Mean population of test insect	Mean quantity of chips damaged (g)
H-226	39.3	154.3
H-1687	101.1	217.7
H-165	85.0	209.3
H-2304	64.0	147.0
H-38	88.3	209.0
H-3641	97.3	207.0
H-312	99.3	201.0
H-97	100.0	200.3
H-2059	90.0	194.7
H-1310	106.3	205.0

infests such crops as cassava, maize, pulses, ginger, and arecanut (Raghunath and Nair 1970). Though it is a serious pest of stored cassava chips, little work has so far been done on the extent of damage and the relative resistance/susceptibility of different cassava varieties. Raghunath and Nair (1970) reported that cassava is the preferred host material of the insect.

### Materials and Methods

Mass culture of *A. fasciculatus* on cassava was maintained in the laboratory from the inoculum obtained from the storehouse. Fresh sun-dried chips (250 g) of uniform size from each of the 10 hybrids were kept in thick polythene bags. Three identical samples were used in the experiment. Ten pairs of freshly emerged test insects were put into each bag for feeding and multiplication. The bags containing host material and test insects were dipped and kept in the laboratory for 45 days. The

bags were then opened, and the number of adult beetles and the quantity of chips powdered were recorded. The data collected were subjected to analysis of variance.

### Results and Discussion

The data presented in Table 1 record the mean number of adult insects (from 39.3 of H-226 to 106.3 of H-1310) obtained and also the mean quantity of cassava chips powdered or damaged in each variety (147 g of H-2304 to 217.7 g of H-1687) after 45 days. The quantity of chips damaged was usually directly proportional to the progeny increase in the test insects. The data indicate that H-226 and H-2304 are significantly superior to the other varieties in not promoting the population buildup of the pest.

There is also a significant difference between H-226 and H-2304 and H-226 has the highest resistance to this insect.

In quantity of chips damaged, all varieties except H-2304 and H-226 are susceptible and significantly inferior, but between these two there is no significant difference.

Thanks are due to Dr N. Hrishi, Director, Central Tuber Crops Research Institute, Trivandrum, for his kind help and for providing necessary facilities. Smt K. R. Lakshmi assisted in the statistical analysis of the data.

Ayyar, T. V. R. *Handbook of economic entomology for South India*. Govt. Press, Madras, 1940, 516.

Nair, M. R. G. K., and Oommen, C. N. *Insect pests of stored arecanut in Kerala*. J. Kir. Acad. Biol. 2(1), 1969, 14-21.

Raghunath, P., and Nair, M. R. G. K. *Host biology relations of Araeceras fasciculatus*. Agri. Res. J. Kerala, 8(1), 1970, 17-21.

## Utilization of Potatoes in the Tropics

N. R. Thompson, R. T. Wurster, and K. D. Sayre<sup>1</sup>

Research at the International Potato Center in Peru has demonstrated that excellent potato yields can be obtained under both intermediate- and low-elevation tropical environments. The potato clones that are well-adapted to these conditions mature quickly (65-90 days). This characteristic allows more flexibility to introduce the potato into current farm-

<sup>1</sup>On leave from Michigan State University, USA; Regional Research and Training, International Potato Center, Lima, Peru, and Department of Plant Physiology, International Potato Center, Lima, Peru, respectively.

ing systems in intermediate- and low-elevation tropical areas. The potential for high carbohydrate production plus the sizable amount of high-quality protein that the potato can produce in short time periods clearly indicates that it can play a very important role in diversifying and improving the nutritional status of many tropical areas.

The potato, indigenous to the tropical latitudes of the high Andes of South America, has travelled a circuitous route and undergone considerable change before returning to its original home. At this Center scientists are exploring its tremendous potential for adaptation to start it on a second world journey, this time in the lower elevations of the tropical and subtropical latitudes.

The Spanish seafarers who carried the potato to Europe made a greater contribution to mankind than those who carried gold and silver. When first introduced into Europe, the potato was poorly adapted to the long days of the temperate zone and was grown as a curiosity in botanical gardens. However, in the next century, through breeding and selection, its value was realized and production reached a peak in the nineteenth century (Salaman 1949).

The potato was classified as a crop of the temperate zone, primarily because of its adoption and use in Europe and North America. Its versatility permits it to be grown under very diverse environmental conditions. The "potato season" can be adjusted to the time of year which provides the most suitable temperature and moisture conditions. It is the most extensively cultivated "root crop" (293.72 million metric tons in 1974). It is grown in a very wide range of climatic zones in over 100 countries. In the Western Hemisphere, it is cultivated from Alaska down through Mexico, Panama, Colombia, Peru, to southern Chile. Because of its frost tolerance it thrives at altitudes too cold for maize. Adaptation to this wide range of environments was achieved by genetic alteration. It is now possible to define the characteristics that will promote its adaptation to tropical and subtropical environments where root crops are important sources of food.

Our results show that excellent yields in the San Ramon area can be produced in a tropical environment (Table 1). Yields as high as 2850 g/plant have been recorded. Some produced over 1000 g/plant in 90 days; one clone produced 1100 g/plant in 65 days. After testing similar cultivars South Korean workers are interested in 80-day potatoes in a multicrop sequence with rice. India is making a major effort to double potato production in the next

5 years. Kenya and the Cameroons are vigorously improving their potato programs. The potato is coming into its own in the tropics and has already gained considerable popularity, particularly among the affluent. However, too often the demand is satisfied by import, so it is essential that research be carried out to adapt the potato to the tropical environment. The addition of this very nutritious food item will help diversify the diet of a large segment of the world's fastest-growing populations.

The importance of potatoes in the early societies of South America and Europe is history. Langer (1963) attributes the European population explosion of the 18th Century to the introduction of the potato. Production from a small plot of ground provided sufficient food for a family and usually a surplus to sell. According to Salaman (1949) this made the industrial revolution possible.

Early South Americans were the first "potato processors." Chuño, probably the world's first freeze-dried food product, originated in the altiplano of Peru and Bolivia and reached its peak during the Inca regime. Ever since, the potato has been among the most reliable foods to ensure man's survival during periods of food shortages. Its use during wartime is well documented. Fresh potatoes are a durable food not easily destroyed by fire, either in the field or in storage.

Unfortunately, man is just relearning the exceptional value of dehydrated potatoes as a product to store, along with cereals, for periods of emergencies. Peare (1973) made a high quality concentrate with 33% protein by removing the large starch grains from potato flour. This Center has initiated research into storage and processing at the village level to preserve the potato for longer periods of time.

The potato is a succulent storage stem containing 70-80% water. This high water content must be considered when potatoes are compared to such foods as wheat, rice, or corn which are nearly dry. For instance, potatoes with 2-3% protein would appear inferior to rice with 7%. However, few cereals are eaten in their natural state. Rice when cooked and prepared for eating contains approximately 2% protein, very similar to potato. In a like

Table 1. Adaptation trial yields in 1974.

Clone	San Ramon		La Molina	
	Metric tons/ha	% solids	Metric tons/ha	% solids
657A-5	60.06	20.1	51.97	21.0
CGN69-1	49.33	20.2	46.20	22.1
69-47-2	43.89	20.9	49.00	21.1
Antarqui	39.50	16.6	40.59	20.0
72/Mast-164	35.97	21.1	29.86	22.2
N512-50	35.64	21.6	30.03	19.8
M1255-16	34.98	24.6	33.46	24.8

comparison bread contains 7–8%. This explains how great civilizations were built on potato, wheat, and rice as the staple foods.

The superiority of potato protein was reported by Kofranyi and Jekat (1967). In human bioassay with potato as the only source of protein, the daily requirement averaged 0.51 g protein/kg body weight. In rat-feeding trials Chang and Avery (1969) found the nutritive value of potato superior to that of rice. Jekat and Kofranyi (1970) demonstrated, by human bioassays, complementary effects of egg protein with potato, soybean, algae, rice, maize, bean, and wheat protein. The minimum protein requirement that maintained nitrogen balance was a mixture of 36% egg protein and 64% potato protein. In nitrogen balance studies, using adults as test individuals, potato protein proved to have the best nutritive value of all analyzed plant proteins, wheat flour, maize, rice, algae, soybean, and kidney bean protein (Kofranyi 1971, 1972). Kaldy (1972) calculated the number of people who could be supplied with protein per hectare per year from various crops, including potatoes (23.5 compared to 40.5 for soybean).

To meet present and especially future world food demands it is now recognized that emphasis must be placed on plants and plant products. Not only will it be necessary to improve on existing sources of food but new sources need to be explored. In the tropics the potato falls into the second category. The potato is one of the four most important food crops (the other three are wheat, rice, and maize).

In the assessment of any food crop, protein and energy must be considered together. The potato provides more of man's daily requirements of protein than energy. Protein cannot be used for growth or maintenance nor can it

prevent the breakdown of tissue protein when the diet does not provide satisfactory quantities of other energy sources such as carbohydrates and fat. Since most human diets have an adequate protein–energy ratio the most practical solution to many food problems seems to be to supply more of the foods already consumed. While monotonous if consumed alone, most supply adequate proteins. When supplemented in a varied diet their total nutritional value will improve. With this in mind, we are studying the potato as a staple food, expecting it to be supplemented by animal or other plant products but serving as a major source of protein, carbohydrates, selected minerals and vitamins. In extending potatoes into the tropics the immediate objective is to increase production in the subtropics. Over half of the people of developing countries (more than 1000 million) live in climatic zones where the potato grows very well. A large portion of the population of countries normally considered tropical or subtropical such as Pakistan, Mexico, Brazil, and Tanzania live in areas where conditions of elevation or water modify the climate sufficiently for good potato production with the cultivars readily available today. Superior clones are rapidly becoming available as well (Table 2). The longer-term goal is to extend into the "true hot, humid, lowland tropics." This second objective will come with the development of genotypes adapted to these extreme conditions.

Potato culture in the subtropics and tropics will have to be modified to accommodate this new environment. Where potatoes have not been grown one can only anticipate problems such as season for planting, fertilization, disease, and pest management. The importance of these will be intensified where production is a year-round activity without frost or periods

Table 2. Yield of selected clones grown in 1975 (in La Molina).<sup>a</sup>

Clone	Yield (kg/ha)	% solids	% protein <sup>b</sup>	RNV <sup>c</sup>
5D 41-41	45870	34.3	8.1	68
3D 80-43	36102	33.8	7.5	66
5D 370-41	32109	25.5	15.5	73
3D 100-2	31878	30.9	6.9	83
3D 376-41	29700	25.7	11.3	75
3D 80-50	25047	30.9	10.8	85
3D 80-37	23628	30.8	7.6	66
3D 80-23	19734	36.3	4.9	74

<sup>a</sup>Courtesy Dr F. de la Puente.

<sup>b</sup>Protein = N × 625.

<sup>c</sup>RNV = Growth of *Streptococcus zymogenes* as a percentage of casein.

of drought to decrease diseases and insects. Once production problems have been identified, seed programs can be initiated. In the early stages seed may have to be imported from traditional production areas. Also potatoes must "fit" established cropping systems. A potato, to complement total production per hectare in a multiple cropping scheme, provides the variation so necessary to many diets.

Potatoes from CIP's breeding programs are grown in Peru in a range of environments from Yurimaguas in the humid tropics to Puno in the altiplano to anticipate their adaptation to similar environments in other countries. Botanical seed and segregating tuber families are available for any potato program wishing to test them. Adaptation to the environment (yield and maturity) influences the production and food value of the potato. It would appear from recent studies that protein production parallels total yield per hectare and is strongly influenced by environment.

Yields, by tradition, have been reported on an area basis, i.e. hundredweight/acre or tons/hectare. In a temperate climate this was satisfactory as, for the most part, only one crop was produced each year. However, in the tropics where land can be cropped continuously, the time element becomes very important. It is misleading to compare the yield of a 90-day crop to the yield of a 300-day crop

on a per hectare basis. For tropical agriculture, a more reasonable measure is yield per unit area per unit of time. Maturity as measured in temperate zones may not be essential. Production of a usable food product is the major criterion. With early-tuberizing cultivars, three to four crops are possible in one year tripling or quadrupling the yield per hectare and providing a continuous harvest to avoid storage problems. On this basis the potato outranks all of the major world food crops including corn, wheat, and rice. Only three short-season crops, soybeans, beans, and peas, outrank the potato in protein production per unit area per unit time. Growing potatoes in the tropics will necessitate major changes in the thinking of scientists from temperate regions as well as for the students of tropical countries trained in temperate regions.

Chang, Y. O., and Avery, E. E. *Nutritive value of potato vs. rice protein*. J. Am. Dietet. Assoc. 55, 1969, 565-568.

Jekat, F., and Kofranyi, E. *Zur Bestimmung der biologischen Wertigkeit von Nahrungsproteinen*. Hoppe Seyler's Z. Physiol. Chem. 351, 1970, 47-51.

Kaldy, M. S. *Protein yield of various crops related to protein value*. Econ. Bot. 261, 1972, 142-144.

Kofranyi, E., and Jekat, F. *Zur Bestimmung der biologischen Wertigkeit von Nahrungsproteinen, XII. Die Mischung von Ei mit Reis, Mais, Soja, Algen*. Hoppe Seyler's Z. Physiol. Chem. 348, 1967, 84-88.

Kofranyi, E. *Biological value of protein mixtures*. Protein Food Supply Repub. S. Afr., Pop. Int. Symp. 1968, 345-353 (Quoted from Chem. Abstr. 78 (1973), Abstr. 109610), 1971.

Kofranyi, E. *Biological value of protein and amino acid mixtures*. Melsunger Med. Mitt. 46 Suppl. 1, 15-23 (Quoted from Chem. Abstr. 78 (1973) Abstr. 83102), 1972.

Langer, W. H. *Europe's initial population explosion*. Am. Historical Review. 49, 1963, 1.

Peare, R. M. *Potato protein as affected by A. Variety and environment and B. Air separation of the dried flour*. MS. thesis, Michigan State University, 1973.

Salaman, R. N. *The history and social influence of the potato*. University Press, Cambridge, England, 1949.

## Summary of Discussions Preharvest and Postharvest Losses

**Rapporteur: J. C. Lozano**

**Discussion Leaders:**

**J. C. Lozano, H. D. Thurston, R. H. Booth, and L. B. Rankine**

The lead paper by H. R. Shuylar, R. H. Gonzalez, W. I. Moller, J. Faure and E. Reusse entitled "Pre- and Postharvest Losses of Tropical Roots and Tubers and Their Reduction" was presented by H. A. Al-Jibouri.<sup>1</sup> The prepared abstract was:

"Pre- and postharvest loss of tropical root and tuber crops is reviewed. Causes of loss in the preharvest period include numerous diseases and insect pests. In general, losses are not considered to be as severe as for other tropical crops although investigation of the problem, comparatively, has not been extensive. Losses due to weeds are poorly known. Current loss control approaches emphasize cultural practices and plant breeding in particular.

"In addition to diseases and insects, postharvest losses are related to processing and marketing, where physiological deterioration frequently occurs. Reduction of postharvest loss centres currently around cultural practices. Chemical controls are not widely used in pre- or postharvest loss reduction.

"Conclusions concerning necessary action to further reduce pre- and postharvest losses in the next 5-10 years include the need for wider use of improved cultural practices. Emphasis first on cassava losses is recommended, then on sweet potatoes, and yams. Priority in reduction loss work should be for the subsistence grower. These suggestions lead to a need for extensive training to strengthen extension activities.

"Cultural practices recommended for the preharvest period include crop rotation and improved mass selection for propagation. Integrated pest management should be possible in some cases with biological control as an important component. Plant breeding research is a continuing need. Further reduction of postharvest losses requires wider use of the best cultural practices in storage; improvements in processing and marketing should also be attainable. Storage and processing losses can be further reduced through applied research."

A synthesis of the discussion follows:

Thurston discussed the importance of plant diseases as limiting factors in food production. The following summary covers the major considerations:

More than 160 bacteria, 250 viruses, and 8000 fungi are known to cause plant disease in addition to mycoplasma-like organisms and viroids which have recently been added to the list. Some include nematodes as disease-producing agents. There are many classic cases of catastrophic plant diseases in history which have wiped out entire crops, often resulting in widespread famine and human disease. Examples are the late blight epidemic of the 1840s in Ireland, coffee rust which last century wiped out coffee in Ceylon, and in 1970 was introduced into Brazil where it has caused great economic loss. As recently as 1942 an epidemic due to brown leaf spot caused the failure of the rice crop in West Bengal and an estimated 2 million people died. Many other examples can be cited, but fortunately the great majority of plant diseases are not catastrophic. Estimates of losses due to plant disease vary widely and much of the information is simply not believed by administrators, the public, and politicians. Most figures found for losses in tropical (developing) countries are double those found for the temperate countries of North America and Europe.

---

<sup>1</sup>The complete text of this paper is available on request from the Cassava Information Centre, CIAT, Cali, Colombia.

## Summary of Discussions Preharvest and Postharvest Losses

**Rapporteur: J. C. Lozano**

**Discussion Leaders:**

**J. C. Lozano, H. D. Thurston, R. H. Booth, and L. B. Rankine**

The lead paper by H. R. Shuylar, R. H. Gonzalez, W. I. Moller, J. Faure and E. Reusse entitled "Pre- and Postharvest Losses of Tropical Roots and Tubers and Their Reduction" was presented by H. A. Al-Jibouri.<sup>1</sup> The prepared abstract was:

"Pre- and postharvest loss of tropical root and tuber crops is reviewed. Causes of loss in the preharvest period include numerous diseases and insect pests. In general, losses are not considered to be as severe as for other tropical crops although investigation of the problem, comparatively, has not been extensive. Losses due to weeds are poorly known. Current loss control approaches emphasize cultural practices and plant breeding in particular.

"In addition to diseases and insects, postharvest losses are related to processing and marketing, where physiological deterioration frequently occurs. Reduction of postharvest loss centres currently around cultural practices. Chemical controls are not widely used in pre- or postharvest loss reduction.

"Conclusions concerning necessary action to further reduce pre- and postharvest losses in the next 5–10 years include the need for wider use of improved cultural practices. Emphasis first on cassava losses is recommended, then on sweet potatoes, and yams. Priority in reduction loss work should be for the subsistence grower. These suggestions lead to a need for extensive training to strengthen extension activities.

"Cultural practices recommended for the preharvest period include crop rotation and improved mass selection for propagation. Integrated pest management should be possible in some cases with biological control as an important component. Plant breeding research is a continuing need. Further reduction of postharvest losses requires wider use of the best cultural practices in storage; improvements in processing and marketing should also be attainable. Storage and processing losses can be further reduced through applied research."

A synthesis of the discussion follows:

Thurston discussed the importance of plant diseases as limiting factors in food production. The following summary covers the major considerations:

More than 160 bacteria, 250 viruses, and 8000 fungi are known to cause plant disease in addition to mycoplasma-like organisms and viroids which have recently been added to the list. Some include nematodes as disease-producing agents. There are many classic cases of catastrophic plant diseases in history which have wiped out entire crops, often resulting in widespread famine and human disease. Examples are the late blight epidemic of the 1840s in Ireland, coffee rust which last century wiped out coffee in Ceylon, and in 1970 was introduced into Brazil where it has caused great economic loss. As recently as 1942 an epidemic due to brown leaf spot caused the failure of the rice crop in West Bengal and an estimated 2 million people died. Many other examples can be cited, but fortunately the great majority of plant diseases are not catastrophic. Estimates of losses due to plant disease vary widely and much of the information is simply not believed by administrators, the public, and politicians. Most figures found for losses in tropical (developing) countries are double those found for the temperate countries of North America and Europe.

---

<sup>1</sup>The complete text of this paper is available on request from the Cassava Information Centre, CIAT, Cali, Colombia.

Table 1. The importance of an integrated approach to increasing effective or utilizable production of root crops.

	Model	Potatoes	Sweet potatoes	Cassava	Yams	Aroids	Misc.	Total
<i>A. Present situation (millions metric tons)</i>								
1. World production (FAO 1974)	100	294	134	105	19	4	3	560
2. 25% postharvest losses (Coursey and Booth 1972)	25	73	34	26	5	1	1	140
3. "Utilized Production" (100-25%)	75	220	101	79	14	3	3	420
<i>B. Possible "Utilizable Production" following research and development (millions metric tons)</i>								
4. Following 5% increase in production (105-25%)	78.75	231	106	83	15	3	3	441
5. Following 5% reduction in postharvest losses (100-20%)	80	235	107	84	15	3	3	448
6. Following 5% increase in production and 5% reduction in postharvest losses (105-20%)	84	247	113	88	16	4	3	470

In addition to the direct losses that occur from plant diseases, the threat of introducing diseases into new areas — countries or continents — is perhaps greater today than at any time. Increased movement of plants from country to country and continent to continent has been highly beneficial to man, but it has resulted in increased movement of diseases around the world. The threat of introducing new diseases is perhaps greatest in tropical areas. Examples of diseases that could move from continent to continent are the Asian downy mildews of maize, the Asia bacterial diseases of rice, African cassava mosaic, moko disease of bananas, lethal yellowing and red ring of coconut, and soybean rust.

Traditional agriculture in large areas of the developing world is giving way to modern agriculture which includes many new inputs. These additional inputs paradoxically and unfortunately often have the potential to increase disease problems. The new high-yielding varieties of wheat and rice involve a relatively small range of genotypes most of which have many common genes such as those for dwarfing. New races of a pathogen or a now-obscure disease or insect pest might have the potential in a given year, with optimal weather conditions, to cause widespread and serious losses. No one, least of all the breeders and plant protectionists of the international centres in developing countries where the high-yielding varieties are grown, would dispute this possibility. However, they are aware of these dangers and have extensive activities to monitor changes in pests and pathogens to reduce the chances of potential disasters. A worldwide cooperative effort to monitor the world movement of pathogens, perhaps including other pests, should be established.

All plant protectionists, entomologists, plant pathologists, nematologists, and weed scientists should work together to develop pest management systems. The problems that the world faces in crop protection are too challenging not to work together to solve them.

Thurston concluded by quoting the following:

"Recent surveys by the UN's Food and Agriculture Organization confirm the startling fact that even today more than one-third of the potential annual world harvest is destroyed by weeds, plant diseases, insects, and other pests. The financial

loss in 1975 was estimated at over 75 billion dollars which was equivalent to the total value of the world's grain harvest together with that of the world's potato crop."

Lozano discussed the environmental factors related to disease development in temperate and tropical zones. He emphasized the following factors: the greater availability of susceptible host material and the existence of a continuous favourable environment for the development of the diseases which jointly result in more frequent incidence of epiphytotics in tropical zones.

Booth stressed the importance of postharvest losses, including those of quality, and the need for a multidisciplinary approach to their reduction. The possible magnitude of these losses is illustrated in Table 1.

Rankine suggested a few approaches for the accurate assessments of crop losses, for example, the determination of the cost of control measures. He also pointed out the need to consider the interest of the following four broad sectors: the industry as a whole, the individual producers, the handlers and processors, etc., and the consumers.

The subsequent open discussion centred around the very real problem of technology transfer in root and tuber crop production systems.

---

## Section 4. Utilization

- 212 The utilization of "bitter" potatoes in the cold tropics of Latin America  
**J. A. Christiansen and N. R. Thompson**
- 215 Cassava utilization in agro-industrial systems **D. J. McCann**
- 221 The allocative efficiency of Fijian root crop producers  
**S. Chandra and A. J. De Boer**
- 226 The importance of cassava processing in the economy of Colombia  
**Hugo Valdes Sanchez**
- 228 A profile of Thai cassava production practices **Truman P. Phillips**
- 232 The prophylactic action of cassava **O. L. Oke**
- 237 The toxic effect of cassava on human thyroid **F. Delange, P. Bourdoux, M. Camus,  
M. Gerard, M. Mafuta, A. Hanson, and A. M. Ermans**
- 242 Utilization of cassava as a carbohydrate source for pigs  
**V. F. Hew and R. I. Hutagalung**
- 246 Use of cassava as a food supplement for broiler chicks **Sarote Khajareern and  
Jowaman M. Khajareern**
- 250 Protein enrichment of cassava by fermentation with microfungi and the role of  
natural nitrogenous supplements **G. Varghese, J. J. Thambirajah, and  
F. M. Wong**
- 255 Utilization of nutritionally improved cassava in poultry and pig diets  
**R. I. Hutagalung and P. H. Tan**
- 262 Utilization of cassava-based diets in swine feeding  
**Guillermo G. Gómez, Carlos Camacho, and Jerome H. Maner**
- 267 Establishment of a pilot plant for the production of fungal protein from cassava  
**K. F. Gregory, A. G. Meiering, F. A. Azi, J. A. D. Sedgwick, J. D.  
Cunningham, S. J. MacLean, J. Santos-Núñez, and G. Gómez**
- 270 Lipase activity and the conversion of fat to carbohydrate in cassava  
**Frederick Nartey**
- 274 A system of food delivery from root crops **T. O. M. Nakayama, James H. Moy,  
and Jose L. F. da Fonseca**
- 275 Mechanization of yam and sweet potato production in Barbados **J. P. W. Jeffers**
- 277 Summary of Discussions **Truman P. Phillips**
- 
-